



HIGHLEAD

GK0058

**Two Needle Double Chain Lockstitch Sewing
Machine**

**Instruction Manual
Parts Catalog**

SHANGHAI BIAOZHUN HAILING SEWING MACHINERY CO., LTD.

CAUTIONS

- 1、 Before filling the oil pan with lubrication oil, please do not start the machine.
- 2、 When starting the machine initially, first turn the machine pulley by hand to bring down the needle bar, then turn on the machine to check rotating direction of the machine pulley, making sure the machine pulley rotates counter-clockwise viewing from the machine pulley side.
- 3、 Within the initial month, do not change for a motor pulley with bigger diameter.
- 4、 Please check power voltage and power phase on the motor.
- 5、 When turning on or operating the machine, please do not put your hands near the needle.
- 6、 When turning over the machine head or removing the V-belt, please turn off the machine
- 7、 When the machine is running, please do not put fingers, hair and any objects close to the V-belt, bobbin winder pulley and motor.
- 8、 Please do not operate the machine without belt guard.
- 9、 This machine can sew at 5500r.p.m. and features dense stitches and automatic lubrication with impeller oil pump.
- 10、 Please read this service manual carefully before operation.

CONTENTS

1、 MACHINE INSTALLATION

- 1) OIL PAN INSTALLATION
- 2) MOTOR PULLEY AND BELT
- 3) BELT GUARD INSTALLATION

2、 MACHINE OPERATION

- 1) PRECAUTION
- 2) LUBRICATION
- 3) NEEDLE THREAD THREADING
- 4) LOOPER THREAD THREADING
- 5) THREAD TENSION ADJUSTMENT
- 6) PRESSER FOOT ADJUSTMENT
- 7) STITCH LENGTH ADJUSTMENT
- 8) NEEDLE INSTALLATION
- 9) SILICON OIL LUBRICATION (OPTION)

3、 MACHINE ADJUSTMENT

- 1) ADJUSTMENT OF PRESSER FOOT AND FEED DOG
- 2) ADJUSTMENT OF NEEDLE BAR AND NEEDLE
- 3) TIMING OF NEEDLE AND LOOPER
- 4) NEEDLE PROTECTOR
- 5) CAM FOR LOOPER THREAD
- 6) POSITION FOR THREAD TAKING-UP
- 7) POSITION FOR INTER-THREAD GUIDE
- 8) NEEDLE GAUGE CHANGING

4、 MACHINE MAINTENANCE

5、 TROUBLE SHOOTING AND REMEDY

1、 MACHINE INSTALLATION

1) OIL PAN INSTALLATION

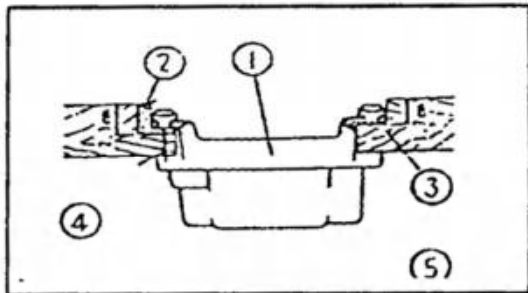

Install the oil pan in the cutout of the table top as shown in the figure. Put the rubber cushions in the corners of the table cutout and rest the oil pan on the rubber cushions.

- (1) Oil pan (2) Rubber cushions (3) Rubber cushions
 (4) Operator (5) Hinge

2) MOTOR PULLEY AND BELT

The maximum sewing speed of GK0058 is 5500r.p.m. Please use a clutch motor of 400W only.

- (1) Motor pulley
 (2) V-type belt
 (3) Diameter

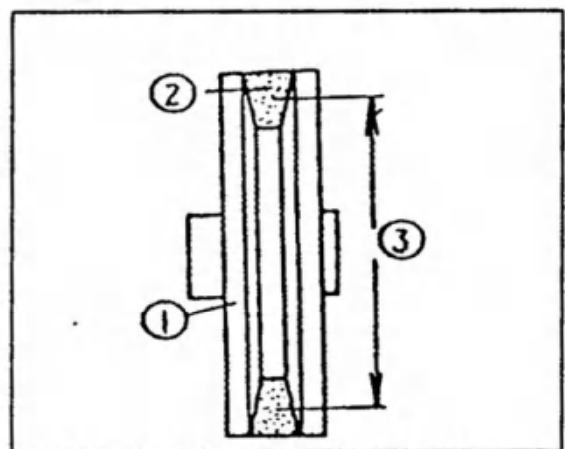

Please always use a V-belt of 42'' or 43'' and refer to the table of relationship between motor pulley and sewing speed as below.

Frequency	Sewing speed	Motor pulley diameter
50Hz	5500 r.p.m.	φ 130
	5000 r.p.m.	φ 120
	4500 r.p.m.	φ 110
60Hz	5500 r.p.m.	φ 110
	5000 r.p.m.	φ 100
	4500 r.p.m.	φ 90

3) BELT GUARD INSTALLATION

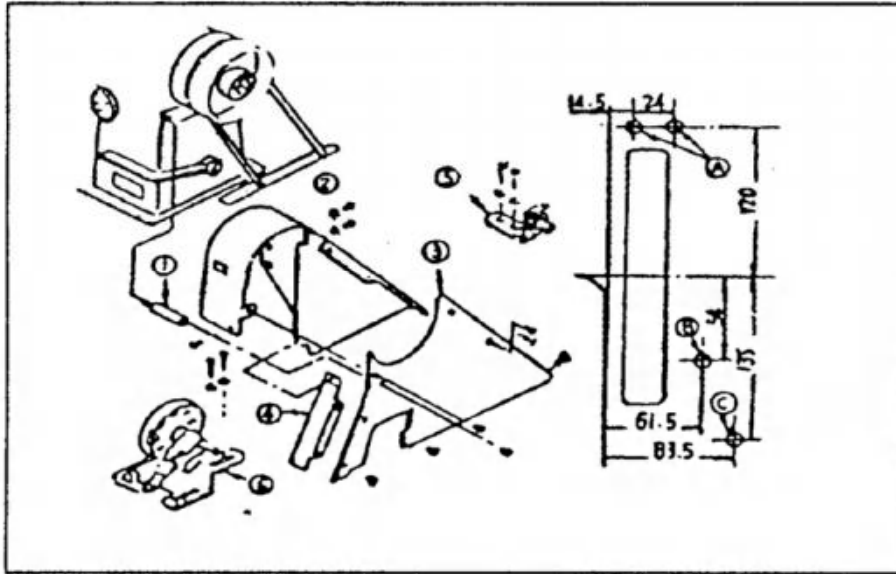

- a) Drill three holes at A,B,C points on the table.
- b) Install stud (1) into the hole in the machine head.
- c) Set temporarily Cover (2) to the machine head with set screws.
- d) Push the machine head backward slightly and install Cover (3) with four screws by tightening.
- e) Fix Cover (3) to stud (1).
- f) Loosen set screws and adjust Cover (2) to the best position, then fasten set screws.

2、 MACHINE OPERATION

1) PRECAUTION

- a) Do not operate the machine before filling oil pan with lubrication oil.
- b) The machine pulley should rotate counter-clockwise viewing from the pulley side. Do not run the machine in a wrong direction.
- c) For a new machine, be sure not to run the machine at over 4500 r.p.m. in the first month.

2) LUBRICATION

- a) Before starting the machine, be sure to fill HA-8 or HJ-7 lubrication oil to “HIGH” line marked on the oil pan.
- b) Be sure that oil level is not below “LOW” line marked on the oil pan.
- c) Oil can be seen spraying from the oil sight window when lubrication is proper.
- d) Change lubrication oil when it gets dirty. Loosen Drain Screw to drain the dirty oil.

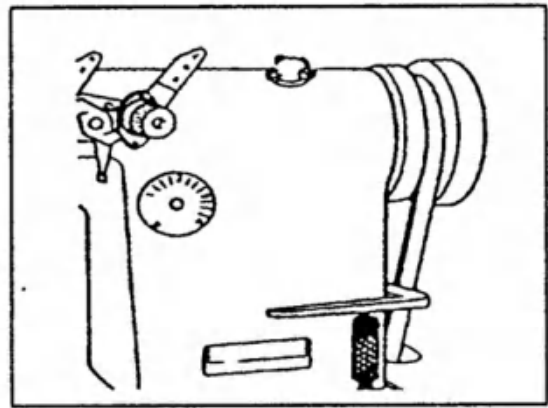
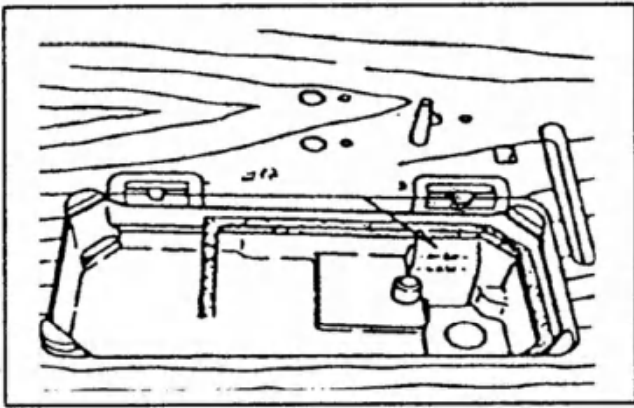

- e) For a new machine or a machine idle for a long time, be sure to lift the presser foot and run the machine idle for 10 minutes at a speed of 3500-4000 r.p.m. for trial running.
- f) When adjusting lubrication for needle bar crank, remove the faceplate, and adjust adjusting screw. Move the indication point on the adjusting screw closest to the crank pin for minimum oil amount and move the point far away from the crank pin for maximum oil amount. Adjust the adjusting screw carefully until the oil amount is changed to satisfaction.

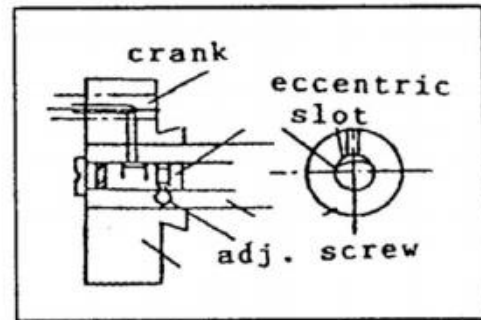
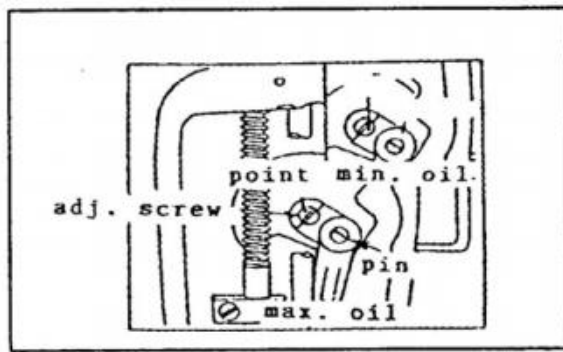

3) NEEDLE THREAD THREADING

Thread the needle thread as shown in the figure, when the needle bar is raised to the highest position:

- a) Thread the needle from the operator side.
- b) Take the thread out of the needle for 10cm long.

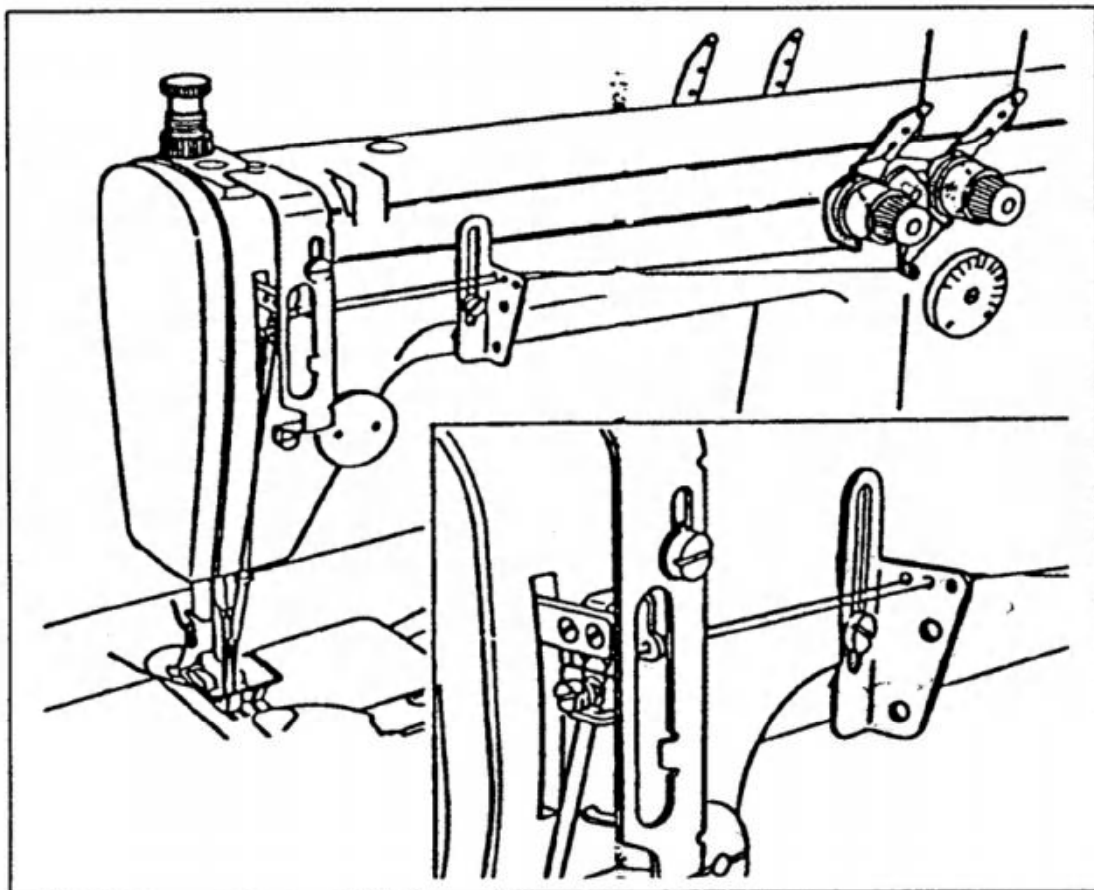

4) LOOPER THREAD THREADING

- a) Thread the looper thread as shown in the figure. Use two holes for strong twisted thread or long stitch length.
- b) Pull the plate spring toward the operator as shown in the figure, and "A" will be lifted up. There are four holes in "A". Use hole (1)(2) for woolen or nylon thread or other stretchy thread or when stitch length is 3mm. Hole (3)(4) are for cotton thread or other less stretchy thread.
- c) When threading loopers use a tweezers in the accessory box and thread as shown in the figure. Pull the thread out of the looper point for 5cm.

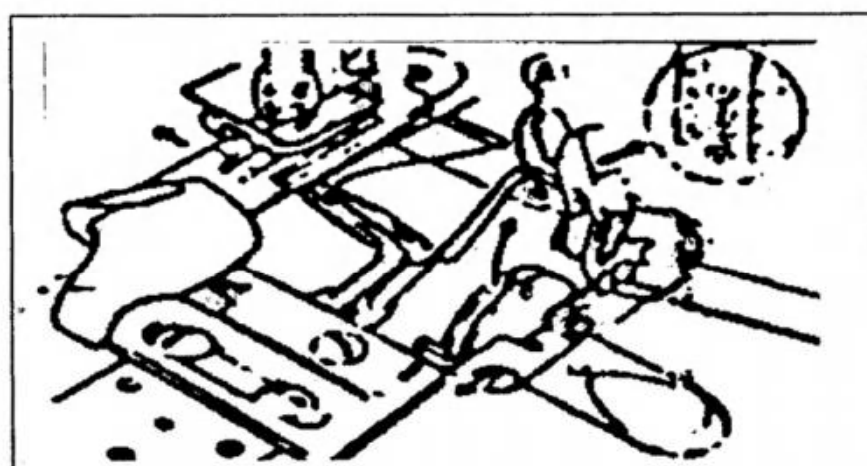
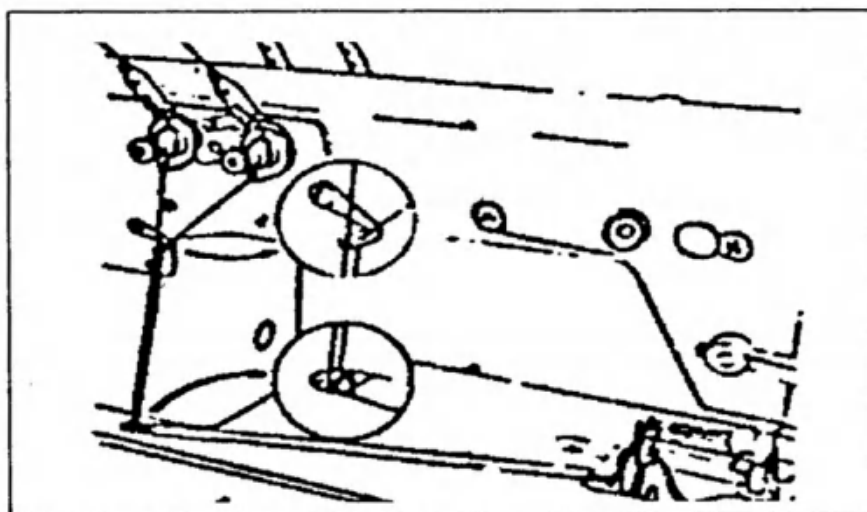

5) THREAD TENSION ADJUSTMENT

Needle thread tension adjustment:

Increase the tension by turning right.

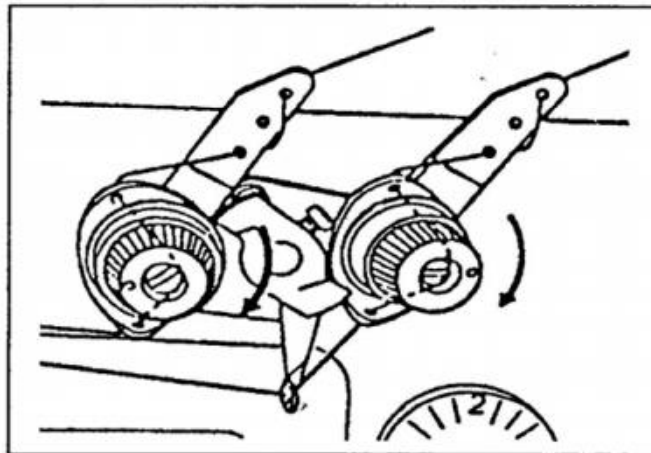

Looper thread tension adjustment:

Increase the tension by turning right.

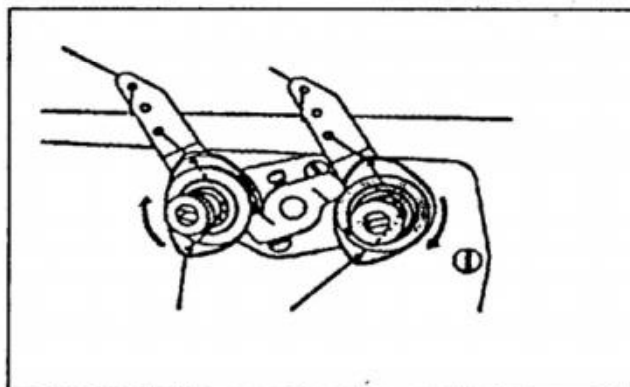

6) PRESSER FOOT ADJUSTMENT

Foot pressure adjustment and presser foot lifting

When the thumb screw is turned right, presser foot pressure will be increased; when the thumb screw is turned left, the pressure will be decreased. A standard pressure should be about 5kg.

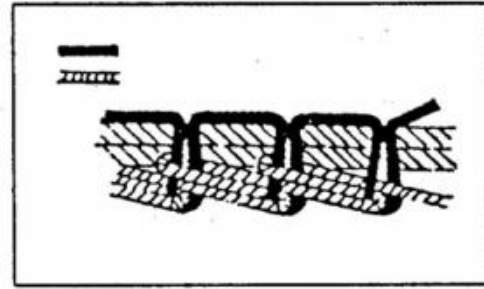
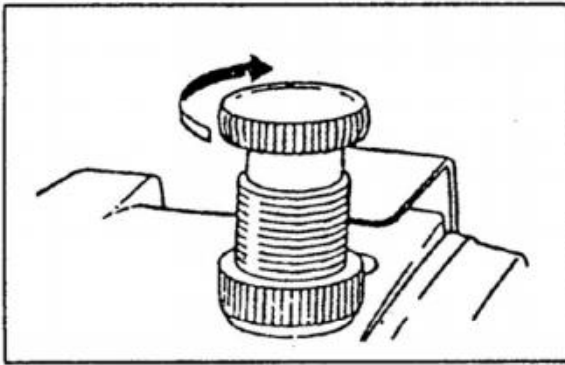

When lifting the presser foot, just turn the presser foot lever left or right.

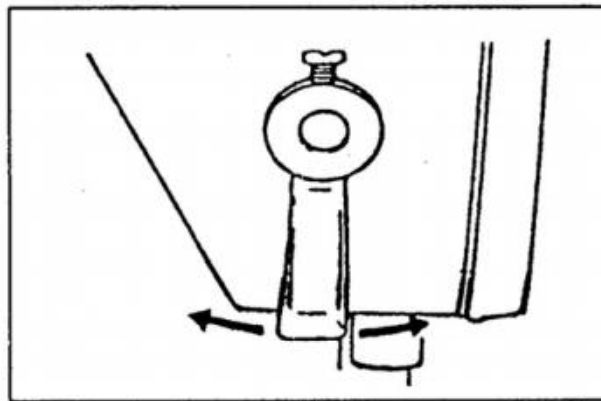

7) STITCH LENGTH ADJUSTMENT

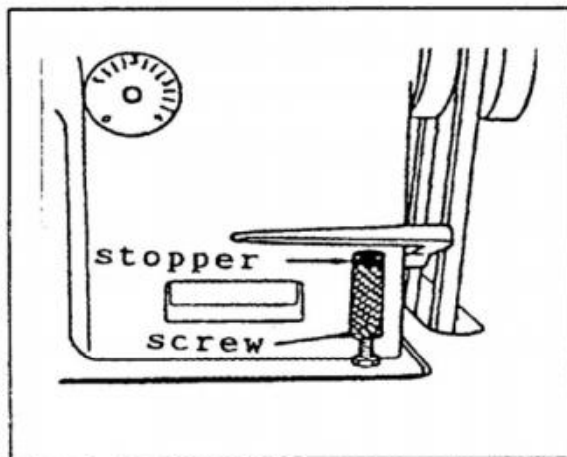

- a) Stitch dial can be turned left or right.
- b) Maximum stitch length is 4mm.
- c) Depress the lever for dense stitching (1.4mm). It is available for seam start and seam end.

8) NEEDLE INSTALLATION

When setting the needle, be sure the needle hole is in accordance with the feeding direction, as shown in figure B.

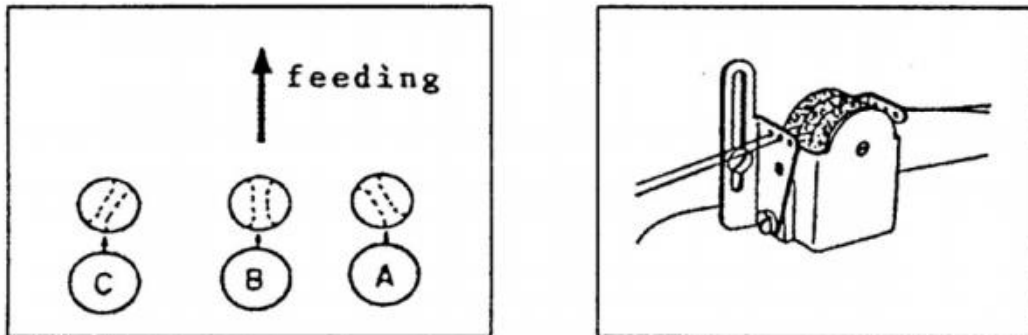

9) SILICON OIL LUBRICATION (OPTION)

A silicon oil lubrication box is available as an option for sewing with synthetic thread. Additional order is required if needed.

3、 MACHINE MAINTENANCE

1) ADJUSTMENT OF PRESSER FOOT AND FEED DOG

A、 Adjust the height of the presser bar

When changing the presser foot, please adjust as follows:

- Remove the rubber plug from the face plate.
- Loosen the set screw for adjusting.
- Tighten the set screw again after adjustment.

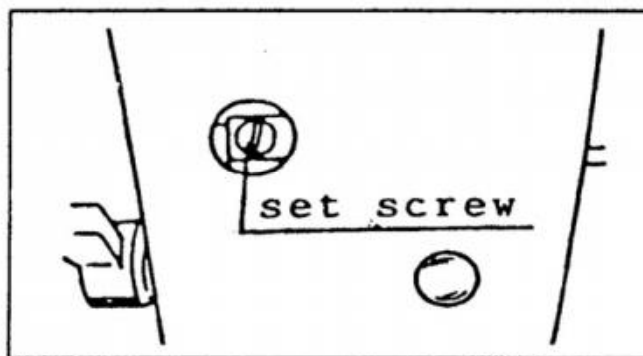

B、 Feed dog installation

Loosen screw (2) as shown in the figure and you can adjust feed dog in Mode A or Mode B, other than the standard mode. The maximum feed dog lift is 0.8mm and can be adjusted by screw (1).

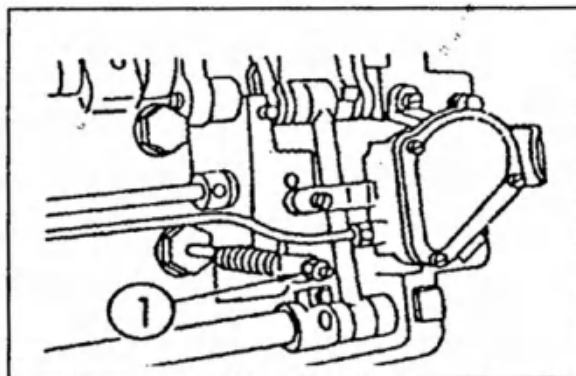
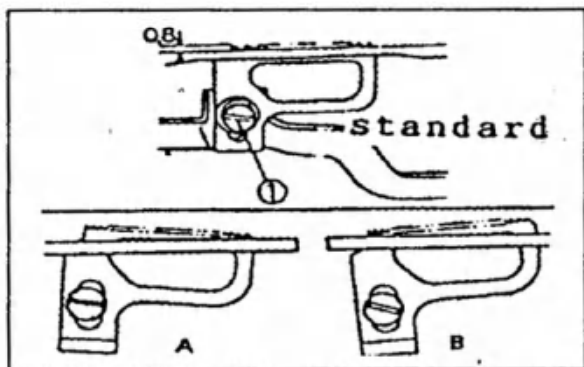

C、 Timing of feed dog and needles

Adjust set screw as shown in the figure, and be sure the feed dog drops completely when the needle point is 3mm from the needle plate.

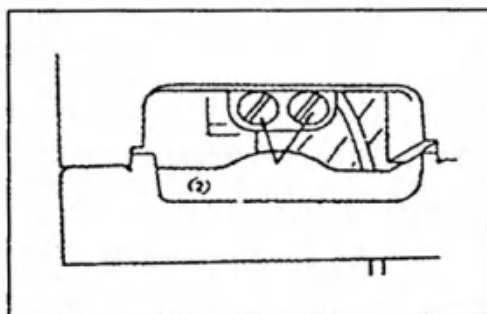

D、 Adjustment of feed connecting rod

When sewing at short stitch length or at low sewing speed, loosen Nut (1) for adjustment, as shown in the figure.

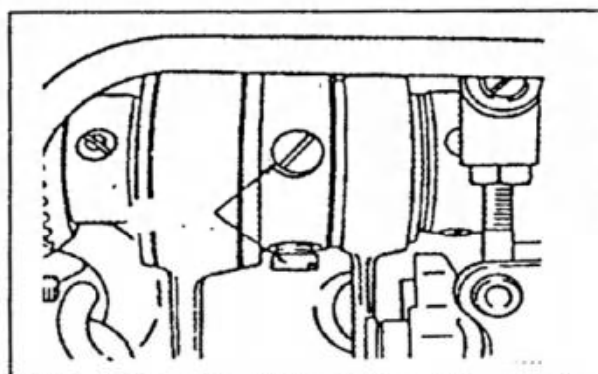

2) ADJUSTMENT OF NEEDLE BAR AND NEEDLE

When using needle (TV × 7) and adjusting the height of needle bar, make sure the mark on the needle bar coincides with the bottom of the needle bar bushing, thus the distance between the needle point and needle plate is 9.5mm.

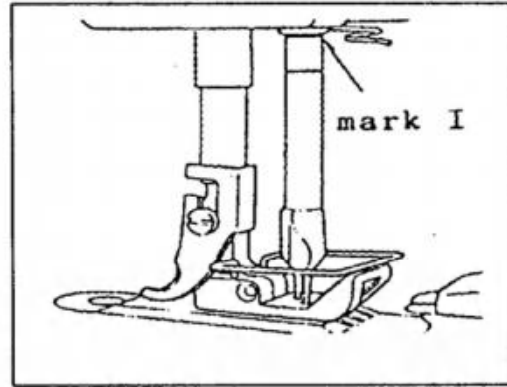

3) TIMING OF NEEDLE AND LOOPER

A. Adjustment of the movement of the looper mechanism depends on “B” size for the elliptical movement of looper mechanism. Generally the maximum “B” size is 3.7mm available for all needle numbers. Adjustment can be proceeded as follows:

- a) Remove the rubber plug.
- b) Turn the machine pulley.
- c) Loosen position screw and flat-headed screw.
- d) Move the mark on the adjusting screw right, “B” size will be increased.
- e) Tighten the flat-headed screw and position screw again after adjustment.

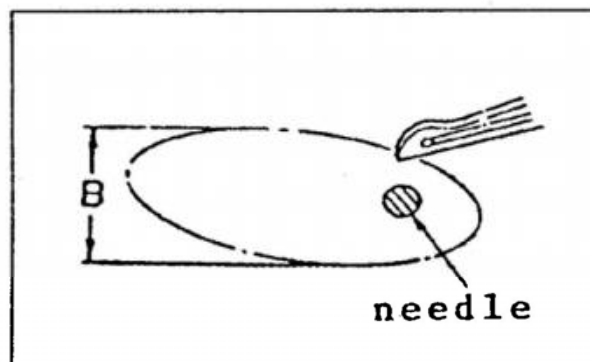

B、 When the needle comes to the lowest position, the looper mechanism will get to the utmost on the right. This adjustment can be done by loosening gear screws to get the timing of needle and looper.

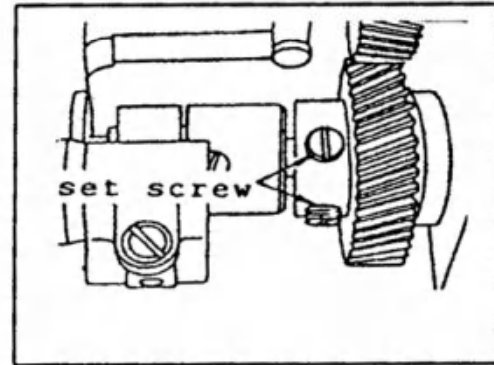
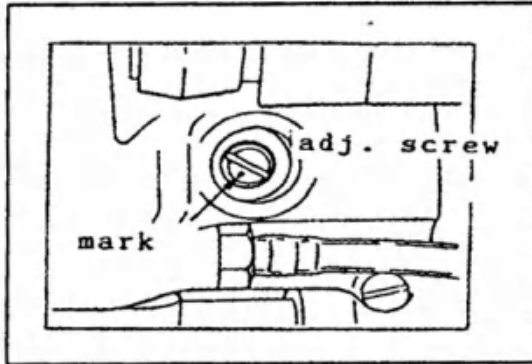

C、 When the looper point gets to the centerline of the needle, the standard distance from looper point to the top of the needle hole is 2mm. When the looper point gets to the utmost on the right of the needle centerline, the standard distance from the looper point to the needle centerline is 3.5mm, meanwhile, line 2 marked on the needle bar just coincides with the bottom of the needle bar bushing, as shown in the figure. Both loopers can be adjusted separately.

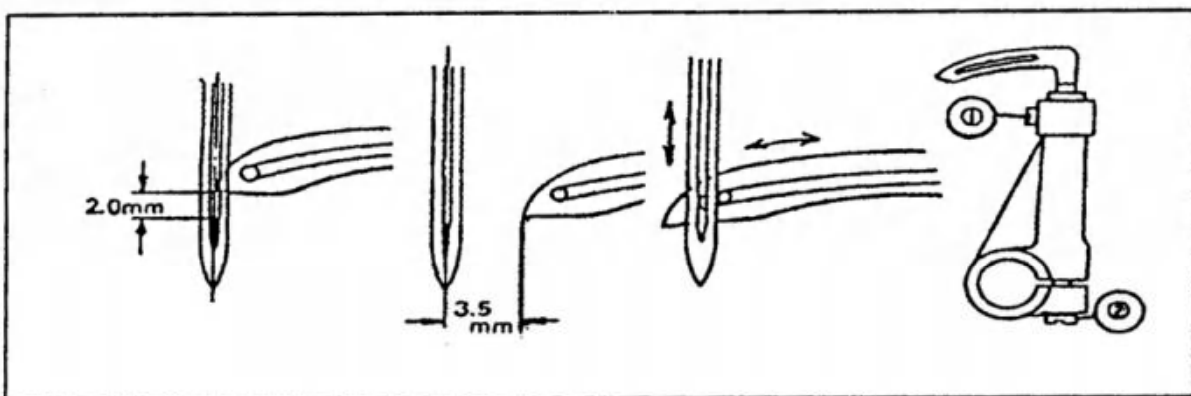

D、 After adjusting looper protector, be sure to check the needle does not touch the looper point. Push the needle slightly by finger. If the clearance is not sufficient, the needle will abrade against the looper, causing damage.

4) NEEDLE PROTECTOR

The timing of rocker needle protector depends on the matching between screw No. 1 and the flat-headed screw as shown in the figure. The right position of rocker needle protector is to keep the needle protector maintained at a proper height and let rocker needle protector brush slightly against the needle when the looper catches thread.

In this case, the distance from the needle to fixed needle protector and rocker needle protector must not be over 0.1-0.2mm. loosen screw (1) and (2) to adjust the rocker needle protector.

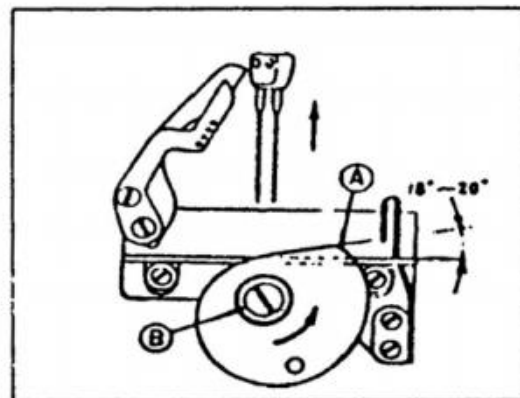
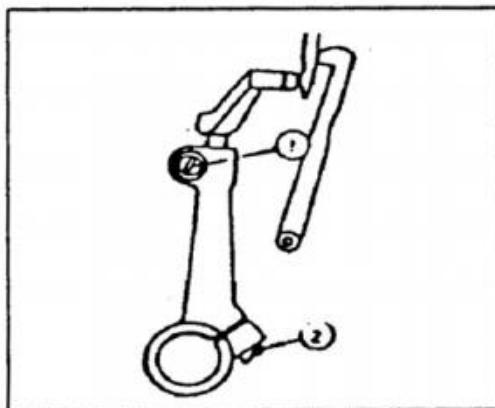
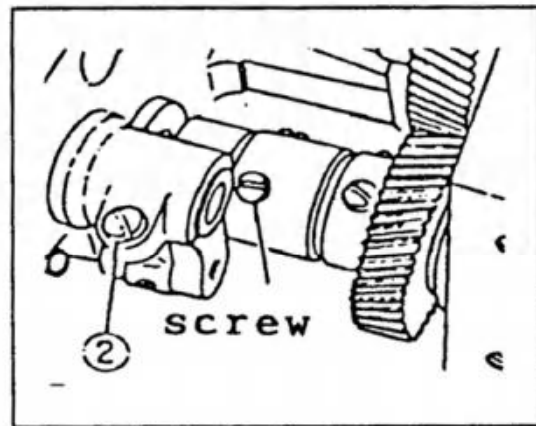

5) CAM FOR LOOPER THREAD

The position of the cam for looper thread should be as shown in the figure. When the needle is lifted to the highest position, the flat side of the cam should be parallel with the wire or slightly above the protruding side. Loosen screw B for adjustment and tighten again after adjusting. When adjusting please check the needle point must enter into the triangle formed by the looper thread completely as the looper thread comes off the protruding side A of the cam.

6) POSITION FOR THREAD TAKING-UP

When thread taking-up of the needle bar is at the lowest position as shown in the figure, the needle thread loop becomes larger and the needle thread loop can be taken in. When using thin thread, lower the thread guide for needle bar to the lowest position.

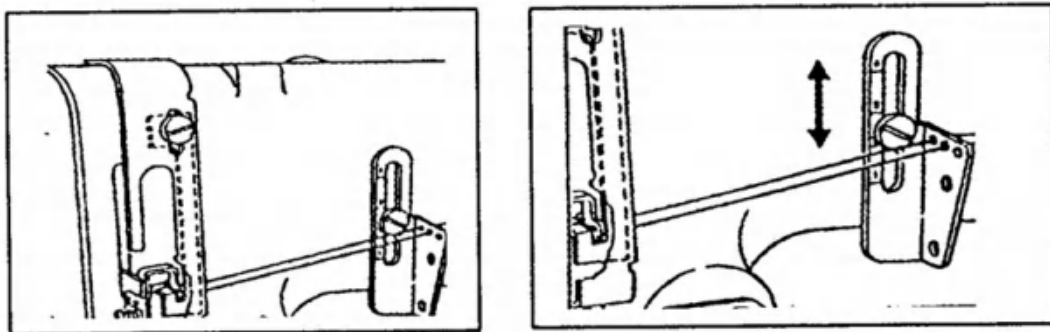

7) POSITION FOR INTER-THREAD-GUIDE

The position for inter-thread-guide sometimes causes thread skipping. Generally use standard positions as follows:

Cotton thread 80#-50#	Position 2-3
Cotton thread 30#-20#	Position 3-4
Synthetic thread 80#-50#	Position 1-2
Synthetic thread 30#-20#	Position 2-3

8) NEEDLE GAUGE CHANGING

The standard needle gauge is 6.4mm. when changing needle gauge, you must change the following parts accordingly:

- a) needle clamp
- b) presser foot
- c) needle plate
- d) feed dog
- e) rocker needle protector
- f) hemmer

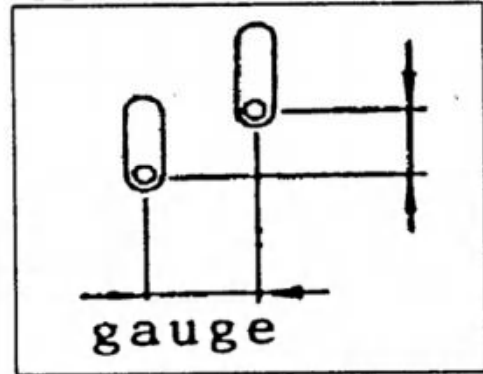

Both right looper and left looper

are available with size from 1/8" to 1/2". If the needle gauge is for larger size, left slide plate and right slide plate should be changed also.

4. MACHINE MAINTENANCE

In order to keep the machine in a good operating condition, please take note of the following:

- 1) Daily checking
 - a) Check the oil sight window to make sure of the proper lubrication.
 - b) If any abnormal noise occurs while operating, contact the mechanic at once.
- 2) Weekly checking
 - a) Remove the needle plate, left slide plate and right slide plate, then clean the dust off the feed dog.
 - b) Clean dust from the filter and oil pan.
 - c) If oil gets dirty, change oil.
- 3) Make sure the oil level in the oil pan should be over Line Low in the oil pan.
- 4) Clean black iron powder from the magnet with soft cloth.

5. TROUBLE SHOOTING AND REMEDY

NO.	TROUBLE	CAUSE	REMEDY
1	Thread breaking	<ol style="list-style-type: none"> 1. Poor thread 2. Thread thicker than needle 3. Needle temperature too high 4. Thread tension too high 5. Parts damage (needle, looper, needle plate, needle protector) 6. Thread re-catching 	<p>Use quality thread Chang proper thread or needle Use silicon oil box or reduce sewing speed Loosen tension nut</p> <p>Polish with grinding stone.</p> <p>Adjust thread taking-up of needle bar</p>
2	Thread skipping	<ol style="list-style-type: none"> 1. Two stitch skipping (Looper failure to catch) 	<ol style="list-style-type: none"> 1. Check thread amount of looper catching 2. Check clearance between needle and looper 3. Check timing of needle and looper 4. Adjust position of inter-thread-guide 5. Adjust thread taking-up position of needle bar as per thread 6. Check needle installation 7. Check timing of rocker needle protector and looper 8. Refer to threading method

		<p>2. One stitch skipping (Needle failure to enter into the loop)</p> <p>3. Incomplete stitches (Needle thread comes in over leftward)</p> <p>4. Others (when synthetic thread used)</p>	<p>1. Check as items 1 and 2 as above</p> <p>2. Check timing of cam for looper thread</p> <p>3. Slightly increase looper thread tension</p> <p>4. Refer to threading method</p> <p>Refer to items 1 and 2</p> <p>1. Lower sewing speed</p> <p>2. Use silicon oil box</p>
3	Poor stitches	<p>1. Needle thread tension too weak</p> <p>2. Looper thread tension too strong</p> <p>3. Looper cam feeding not sufficient</p> <p>4. Thread too thick in relation to needle</p> <p>5. Improper position of inter-thread-guide</p>	<p>1. Tighten tension nut of needle thread</p> <p>2. Loosen tension nut of looper thread</p> <p>3. Adjust the threading position of looper cam</p> <p>4. Change needle</p> <p>5. Lower the position of inter-thread-guide</p>

4	Needle breaking	<p>6. Improper position of top thread guide on needle bar</p> <p>7. Needle plate</p> <p>1. Needle bent 2. Feed dog and needle not timed 3. Presser foot not installed properly</p> <p>4. Rocker needle protector not timed 5. Needle thread tension too strong</p> <p>6. Improper needle</p>	<p>6. Raise the position of top thread guide on needle bar</p> <p>7. Use a needle plate with bigger needle hole</p> <p>1. Change needle 2. Adjust timing</p> <p>3. Make sure the hole on presser foot and the hole on needle plate must be aligned with needle center</p> <p>4. Check timing</p> <p>5. Loosen tension nut of needle thread</p> <p>6. Use proper needle as per fabric</p>
5	Puckering	<p>1. Thread tension too strong</p> <p>2. Looper cam not timed</p> <p>3. Thread guide not smooth</p> <p>4. Presser foot pressure too strong</p>	<p>1. Decrease thread tension, especially for looper thread</p> <p>2. Check timing</p> <p>3. Abrade thread guide</p> <p>4. Loosen the adjusting screw of presser foot</p>

6、 MAIN SPECIFICATION

- 1) Sewing mode: two needle double chain stitching
- 2) Max. Sewing speed: 5500 r.p.m.
- 3) Needle: TV×7 #9-#21
- 4) Stitch length: 1.4mm (1/16")-4mm (5/32")
- 5) Dense seam: by lever
- 6) Needle bar stroke: 30mm
- 7) Needle gauge: 3.2, 4, 4.8, 5.6, 6.4, 8, 9.5, 12.7
- 8) Thread take-up: needle bar thread take-up
- 9) Looper mechanism: adjustable individually and available from 1/8"-1/2"
- 10) Needle protector: with both rocker needle protector and fixed needle protector
- 11) Presser foot lift: 8mm-10mm by knee
- 12) Lubrication: by impeller oil pump
- 13) Lubrication oil: HA-8,HJ-7 machine oil

* The specifications are subject to change without notice.

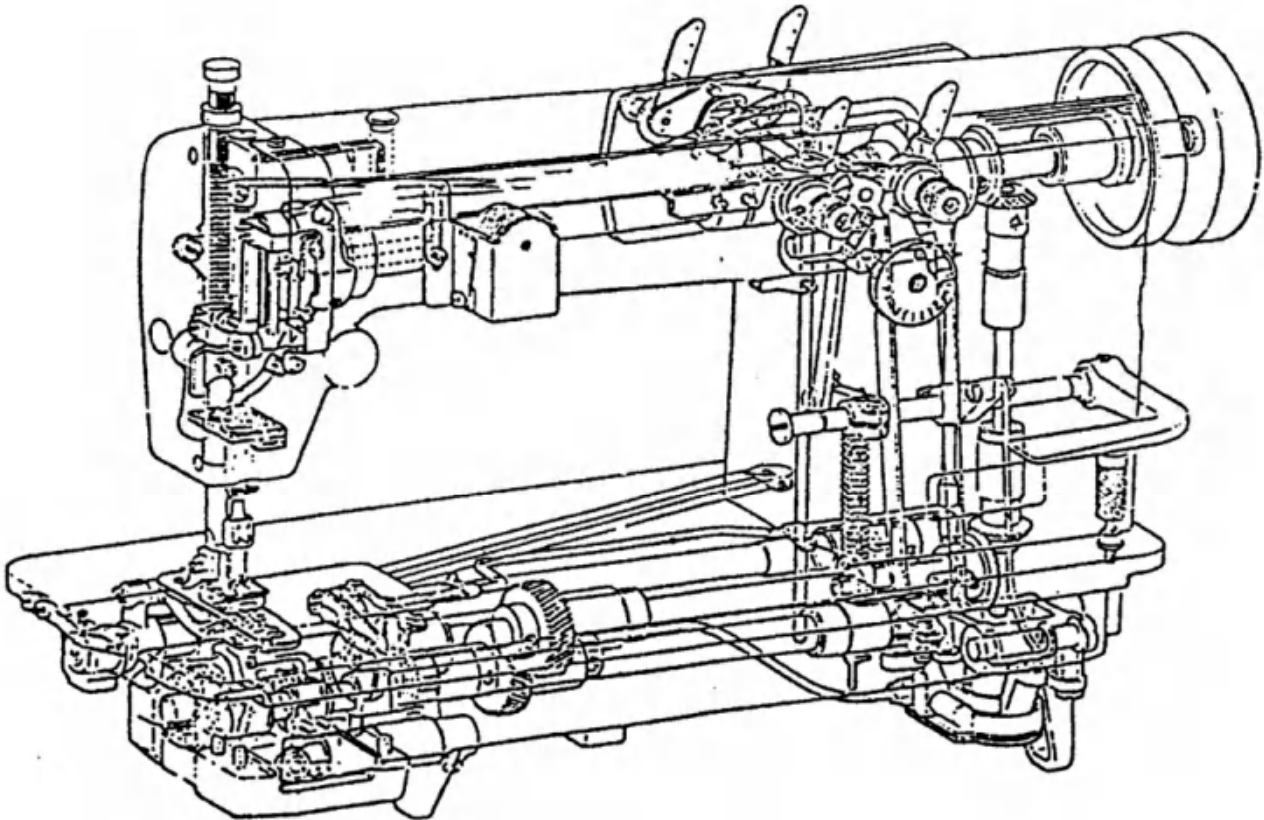

ARM & BED MECHANISM

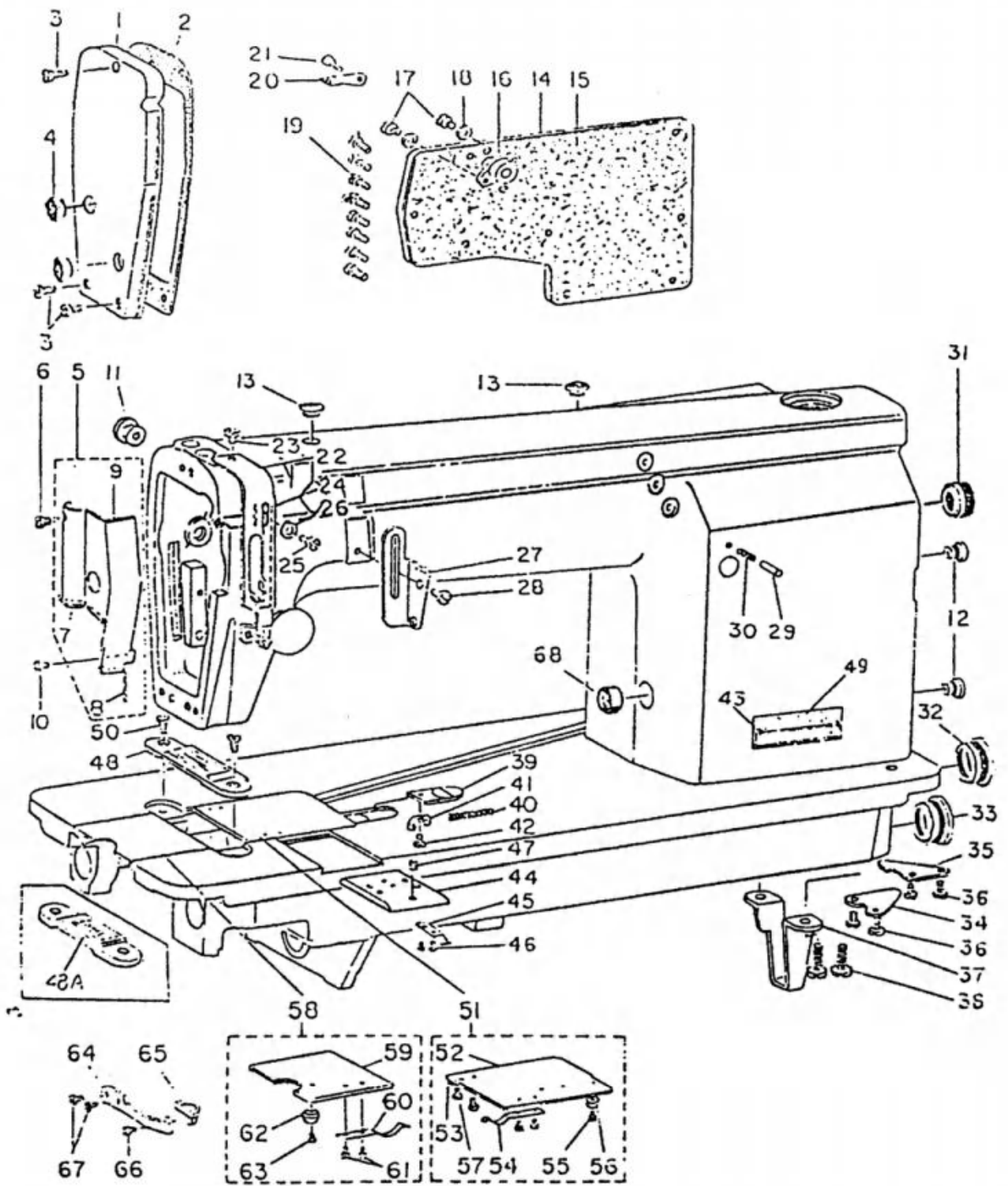

ARM & BED MECHANISM

No.	Part Number	Description	Q' ty	Remarks
1	5S1-12	Face plate	1	
2	5S1-13	Gasket	1	
3	22T1-004	Screw	3	
4	22T1-003C4	Rubber plug	2	
5	5S1-018D	Oil wick holder assy	1	
6	5S1-04	Screw	1	
7	5S1-018D2	Oil braid for needle bar	1	
8	5S1-018D3	Oil wick for needle bar	1	
9	5S1-018D1	Oil wick holder	1	
10	22T2-004	Screw	1	
11	22T1-003C4	Rubber plug	1	
12	22T1-015	Rubber plug	2	
13	22T1-003C4	Rubber plug	2	
14	5S1-19	Side cover	1	
15	5S1-20	Gasket for side cover	1	
16	5S1-27E	Bushing assy for thread releasing	1	
17	5S1-28	Screw	2	
18	5S1-29	Washer	2	
19	22T1-004	Screw	8	
20	5S1-21	2-eyed thread guide	1	
21	22T2-004	Screw	1	
22	5S1-15	Cover plate for thread take-up	1	
23	22T2-004	Screw	2	
24	5S1-14	Tensioner for thread take-up	1	
25	22T2-004	Screw	1	
26	22T1-007	Washer	1	
27	5S1-16	Inter-thread-guide	1	
28	22T2-019	Screw	1	
29	5S4-27	Stop pin	1	
30	5S4-26	Stop pin spring	1	
31	5S1-17	Rubber plug	1	
32	5S1-32	Rubber plug	1	
33	5S1-32	Rubber plug	1	
34	5S1-26	Front oil shield	1	
35	5S1-33	Back oil shield	1	
36	22T2-004	Screw	4	

ARM & BED MECHANISM

No.	Part Number	Description	Q' ty	Remarks
37	5S1-31	Bracket	1	
38	5S1-30	Screw	2	
39	5S1-02	Opener for right slide plate	1	
40	5S1-03	Opener spring	1	
41	5S1-05	Backing plate	1	
42	5S1-04	Screw	1	
43	22T1-002B3	Rivet	2	
44	5S1-06	Adjusting plate	1	
45	5S1-08	Lock spring	1	
46	J9. 0. 3	Screw	2	
47	5S1-07	Set Screw	1	
48	5S1-10	Needle plate 1/4"	1	
49	5S1-25	Name plate	1	
50	J0. 0. 27	Screw	2	
51	5S1-09B	Right slide plate assy.	1	
52	5S1-09B1	Right slide plate	1	
53	5S1-09B4	Position plate	1	
54	5S1-09B3	Position spring	1	
55	61. 04. 01/B7/Z1	Screw	1	
56	5S1-09B2	Lock ring	1	
57	J9. 0. 3	Screw	4	
58	5S1-11C	Left slide plate assy.	1	
59	5S1-11C1	Left slide plate	1	
60	5S1-11C2	Position spring	1	
61	J9. 0. 3	Screw	2	
62	5S1-11C3	Lock ring	1	
63	61. 04. 01/B7/Z1	Screw	1	
64	5S1-24	Opener spring	1	
65	5S1-23	Opener for left slide plate	1	
66	6A2-14	Screw	1	
67	22T2-004	Screw	2	
48A	5S1-10-3	Needle plate	1	Tandem

ARM SHAFT AND NEEDLE BAR MACHANISM

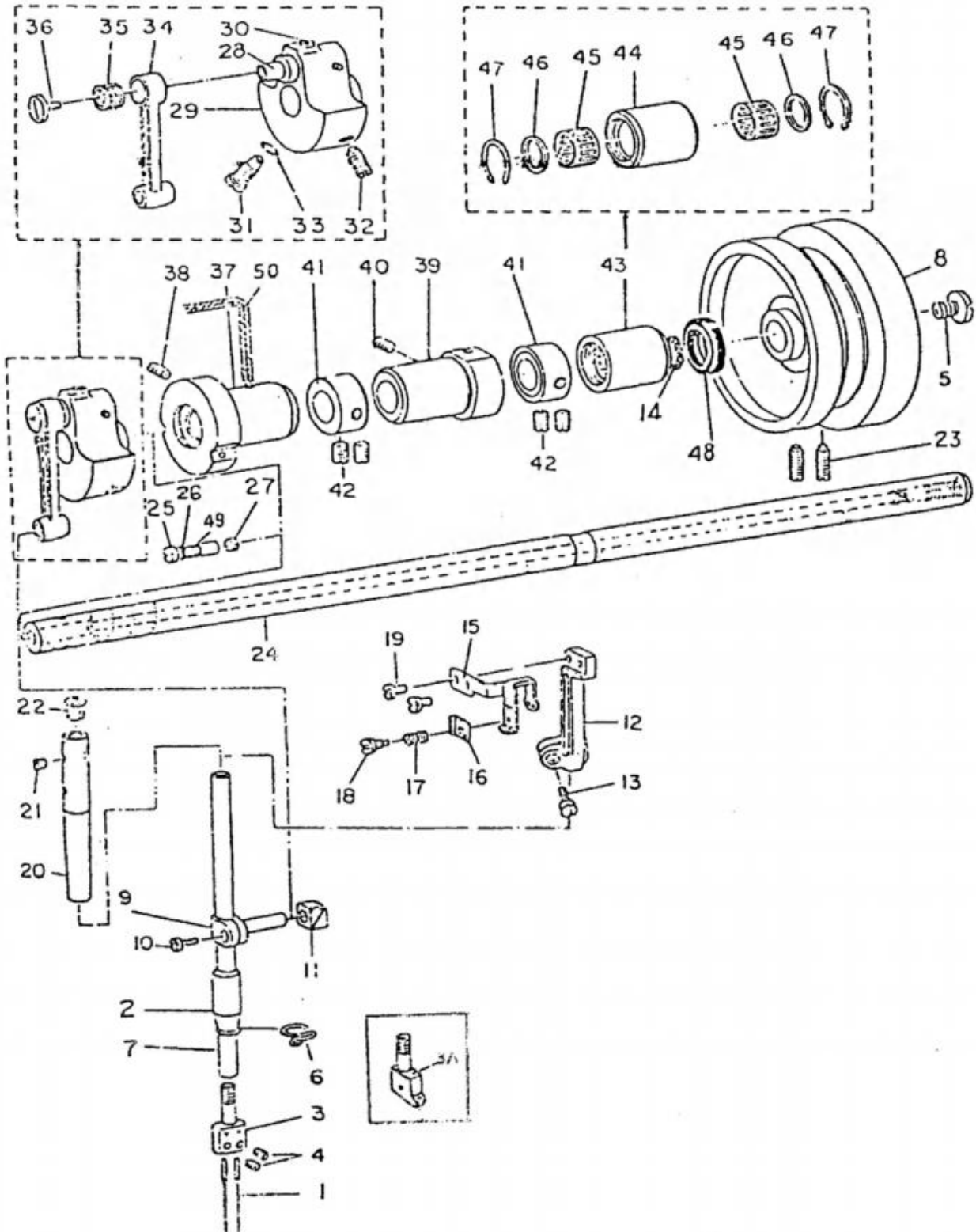

ARM SHAFT AND NEEDLE BAR MECHANISM

No.	Part Number	Description	Q' ty	Remarks
1	TV×7 #14	Needle	2	
2	5S2-4	Needle bar bushing (lower)	1	
3	5S2-2	Needle clamp	1	
4	22T2-013	Screw	2	
5	5S8-5	Screw	1	
6	22T2-012C2	Thread guide	1	
7	5S2-3	Needle bar	1	
8	5S2-22	Machine pulley	1	
9	5S2-6	Needle bar adaptor	1	
10	22T2-001A9	Screw	1	
11	5S2-1	Slide block	1	
12	5S2-25	Bracket for thread take-up	1	
13	5S2-26	Screw	1	
14	5S2-20B3	Self-lock spring	1	
15	5S2-24	Thread take-up lever	1	
16	5S2-28	Tension plate	1	
17	5S2-27	Tension spring	1	
18	5S2-29	Tension screw	1	
19	22T2-001A9	Screw	2	
20	5S2-11	Needle bar bushing (upper)	1	
21	5S2-10	Screw	1	
22	22T2-011	Rubber plug	1	
23	22T3-007C2	Screw	2	
24	5S2-16	Arm shaft	1	
25	5S2-8	Adjusting valve for oil amount	1	
26	GB3452.1-82	O-ring	1	
27	5S2-13	Felt	1	
28	5S2-7	Hinge stud	1	
29	5S2-12	Needle bar crank	1	
30	J0. 0. 81	Screw	1	
31	22T2-007	Set Screw	1	
32	5S2-23	Screw	1	
33	GB3452.1-82	O-ring	1	
34	5S2-5	Connecting rod	1	
35	10242/8	Needle bearing	1	
36	22T2-001A6	Screw	1	

ARM SHAFT AND NEEDLE MECHANISM

No.	Part Number	Description	Q' ty	Remarks
37	5S2-15	Bushing (left)	1	
38	J0.040	Screw	1	
39	5S2-18	Bushing (middle)	1	
40	J0.040	Screw	1	
41	5S2-17	Stop ring	2	
42	22T2-005B3	Set Screw	4	
43	5S2-19	Bushing (right)	1	
44	5S2-19A1	Outer ring	1	
45	5S2-19A3	Bearing needle and retainer assy.	2	
46	5S2-19A2	Retaining ring	2	
47	GB893.1-86-21	Stop ring	2	
48	5S2-20	Rubber ring	1	
49	5S2-9	Seal ring	1	
50	5S2-14	Oil wick	1	
3A	5S2-2-3	Needle clamp	1	Tandem

PRESSER BAR, VERTICAL SHAFT AND LOWER SHAFT MECHANISM

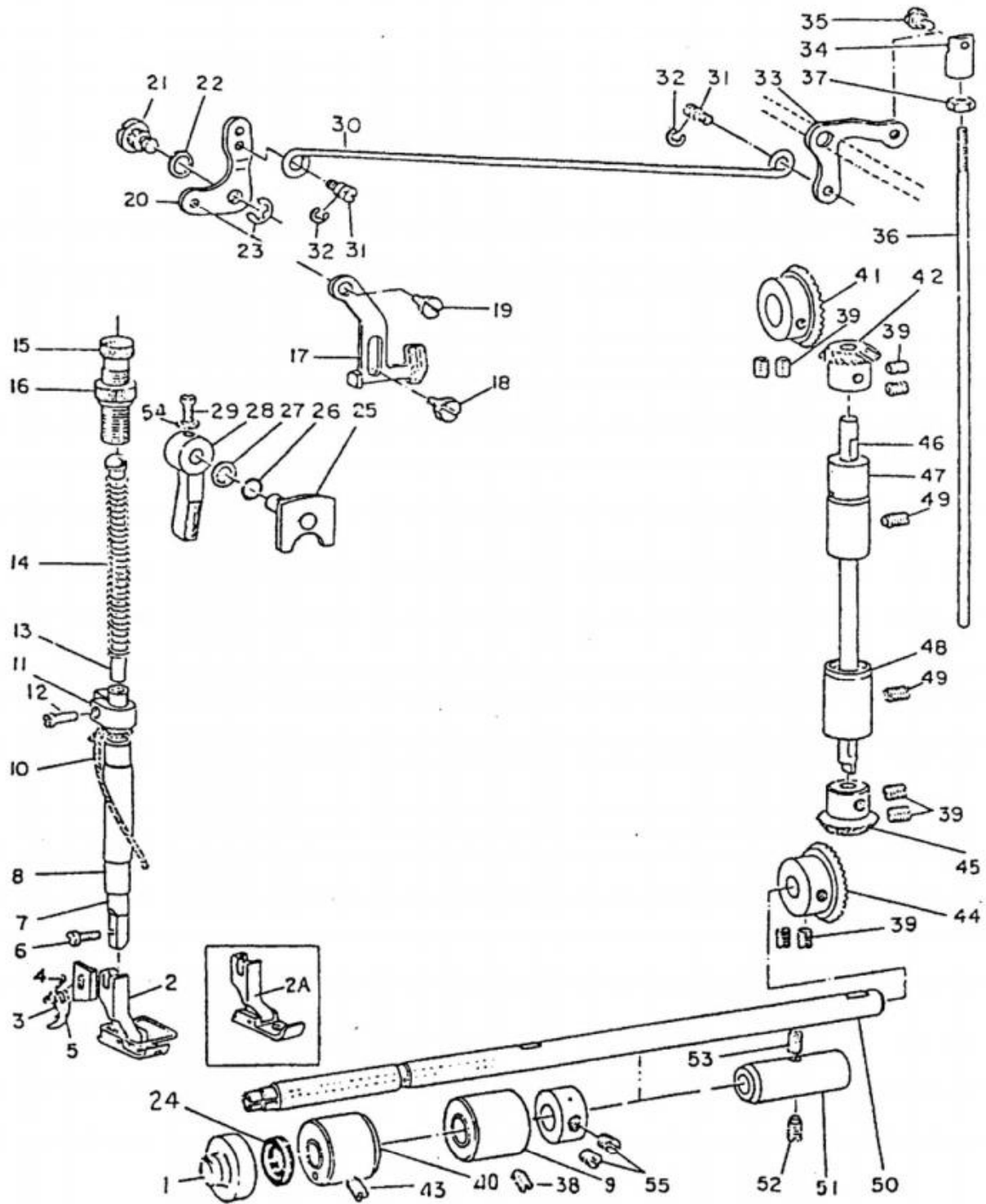

PRESSER BAR, VERTICAL SHAFT AND LOWER SHAFT MECHANISM

No.	Part Number	Description	Q'ty	Remarks
1	5S3-33	Bushing	1	
2	5S3-23B	Presser foot assy.	1	
3	5S3-24	Thread cutter	1	
4	5S3-16	Thread cutter guide	1	
5	6A1-a04	Screw	1	
6	22T7-015	Screw	1	
7	5S3-22	Presser bar	1	
8	5S3-21	Bushing	1	
9	5S3-30	Bushing (middle)	1	
10	5S3-20	Oil wick	1	
11	5S3-19	Presser bar guide	1	
12	J0.0.45	Screw	1	
13	22T7-012	Guide stud	1	
14	22T7-013	Presser bar spring	1	
15	22T7-014E1	Adjusting stud	1	
16	22T7-014E2	Thumb nut	1	
17	5S3-1	Presser foot lifting bracket	1	
18	5S3-2	Screw	1	
19	5S3-3	Screw	1	
20	5S3-5	Knee lifter lever (left)	1	
21	5S3-10	Screw	1	
22	5S3-9	Washer	1	
23	GB894-76	Stop ring 7	1	
24	5S3-32	Oil seal	1	
25	5S3-13A	Presser bar lifting cam assy.	1	
26	GB3452.1-82	O-ring	1	
27	5S3-14	Washer	1	
28	5S3-15	Presser foot lifter lever	1	
29	6A2-27	Screw	1	
30	5S3-6	Knee lifting rod	1	
31	5S3-4	Screw	2	
32	GB894-76	Stop ring 6	2	
33	5S3-7	Knee lifting lever (right)	1	
34	5S3-8	Connection joint	1	
35	5S3-35	Screw	1	
36	5S3-28	Connecting rod	1	

PRESSER BAR, VERTICAL SHAFT AND LOWER SHAFT MECHANISM

No.	Part Number	Description	Q' ty	Remarks
37	22T6-001A8	Nut	1	
38	22T2-002	Screw	1	
39	22T2-005B3	Set Screw	8	
40	5S3-31	Bushing (left)	1	
41	22T3-010E2a1	Bevel gear	1	
42	22T3-010E2a2	Bevel gear	1	
43	22T2-002	Screw	1	
44	22T3-010E2a1	Bevel gear	1	
45	22T3-010E2a1	Bevel gear	1	
46	5S3-18	Vertical shaft	1	
47	5S3-11	Bushing (upper)	1	
48	5S3-17	Bushing (lower)	1	
49	22T2-002	Screw	2	
50	5S3-34	Lower shaft	1	
51	5S3-26	Bushing (right)	1	
52	22T2-002	Screw	1	
53	5S3-27	Felt	1	
54	5S3-12	Washer	1	
55	22T2-005B3	Set Screw	2	
2A	5S3-23B-3	Presser foot assy.	1	Tandem

STITCH REGULATING MACHANISM

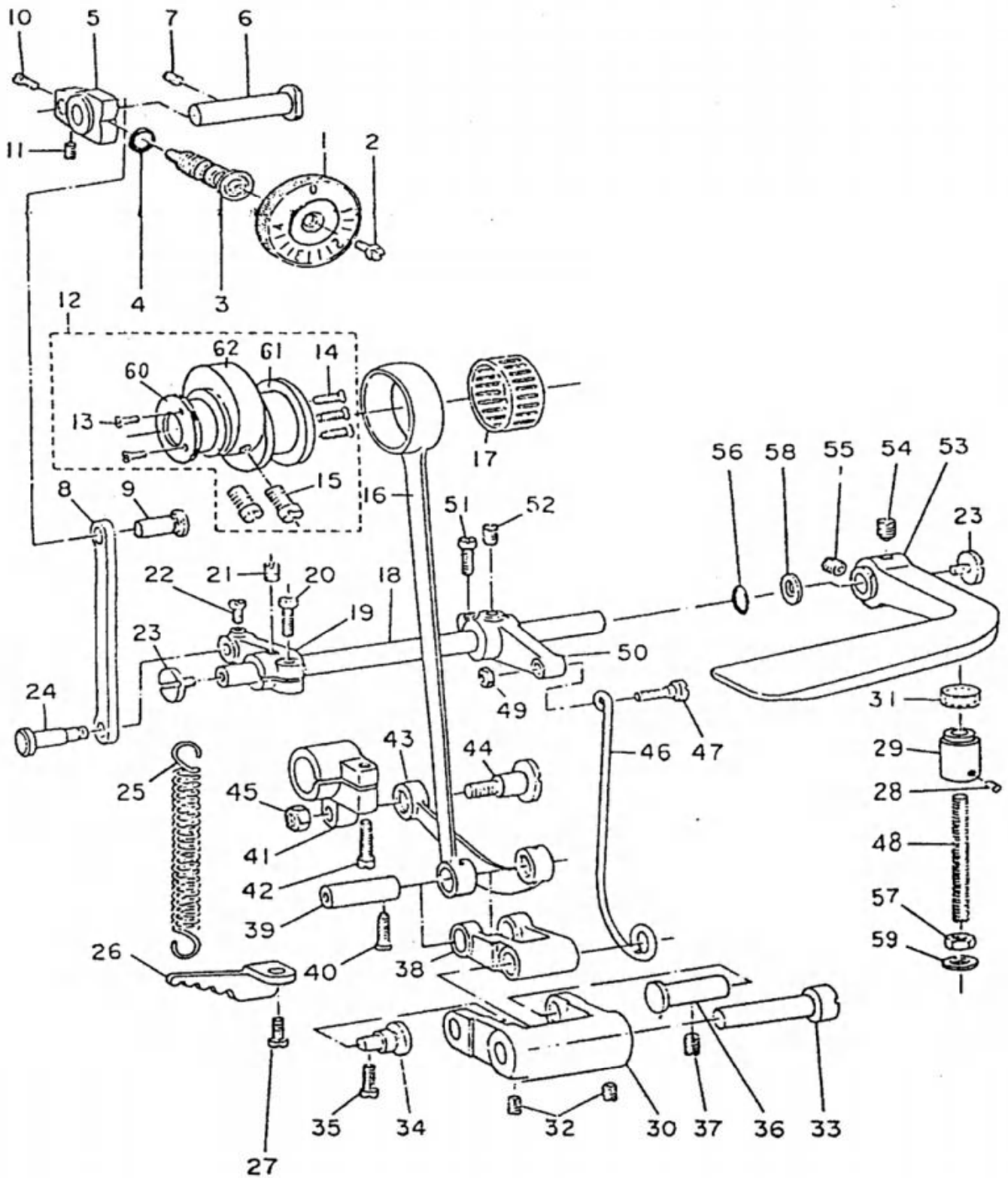

STITCH REGULATING MECHANISM

No.	Part Number	Description	Q' ty	Remarks
1	5S4-28	Dial	1	
2	5S4-30	Screw	1	
3	5S4-29K1	Regulating screw	1	
4	GB1235	O-ring	1	
5	5S4-11D2	Stitch regulating block	1	
6	5S4-12	Pin	1	
7	22T2-002	Screw	1	
8	5S4-14	Stitch regulator link	1	
9	5S4-13	Pin	1	
10	5S4-11D1	Screw	1	
11	5S4-11D2	Screw	1	
12	5S4-18G	Feed cam assy.	1	
13	5S4-18G6	Screw	2	
14	5S4-18G1	Screw	3	
15	5S4-18G4	Screw	2	
16	5S4-20	Feed connection rod	1	
17	9241/23	Bearing	1	
18	5S4-231	Lever shaft	1	
19	5S4-15E2	Front crank	1	
20	5S4-15E1	Screw	1	
21	61-04-01/B3	Screw	1	
22	5S4-15E3	Screw	1	
23	5S4-24	Screw	2	
24	5S4-16	Pin	1	
25	5S4-46	Spring	1	
26	5S4-47	Hanger	1	
27	5S4-48	Screw	1	
28	21T3-003	Screw	1	
29	5S4-32M2	Stopper bushing	1	
30	5S4-55T1	Crank	1	
31	5S4-32M1	Rubber ring	1	
32	5S4-04C2	Screw	2	
33	5S4-54	Long pin	1	
34	5S4-51	Short pin	1	
35	5S4-48	Screw	1	
36	5S4-54	Long pin	1	

STITCH REGULATING MECHANISM

No.	Part Number	Description	Q' ty	Remarks
37	J0.081	Screw	1	
38	5S4-53	Feed driving rock arm	1	
39	5S4-52	Pin	1	
40	22T6-008D3	Screw	1	
41	5S4-45R1	Feed crank	1	
42	61-04-01/B5	Screw	1	
43	5S4-49	Feed rocker	1	
44	5S4-42	Pin	1	
45	5S4-43	Nut	1	
46	5S4-22	Pull bar	1	
47	5S4-21H2	Pin	1	
48	5S4-32M3	Screw bar	1	
49	5S4-21H3	Nut	1	
50	5S4-21H1	Back crank	1	
51	5S4-15E1	Screw	1	
52	61-04-01/B3	Screw	1	
53	5S4-31L3	Lever	1	
54	5S4-31L2	Screw	1	
55	5S4-31L1	Screw	1	
56	GB1235	O-ring	1	
57	5S4-33	Nut	1	
58	GB95	Washer 10	1	
59	5S4-34	Washer	1	
60	5S4-18G2	Small spacer	1	
61	5S4-18G5	Big spacer	1	
62	5S4-18G3	Feed cam	1	

FEED & FEED LIFTING MECHANISM

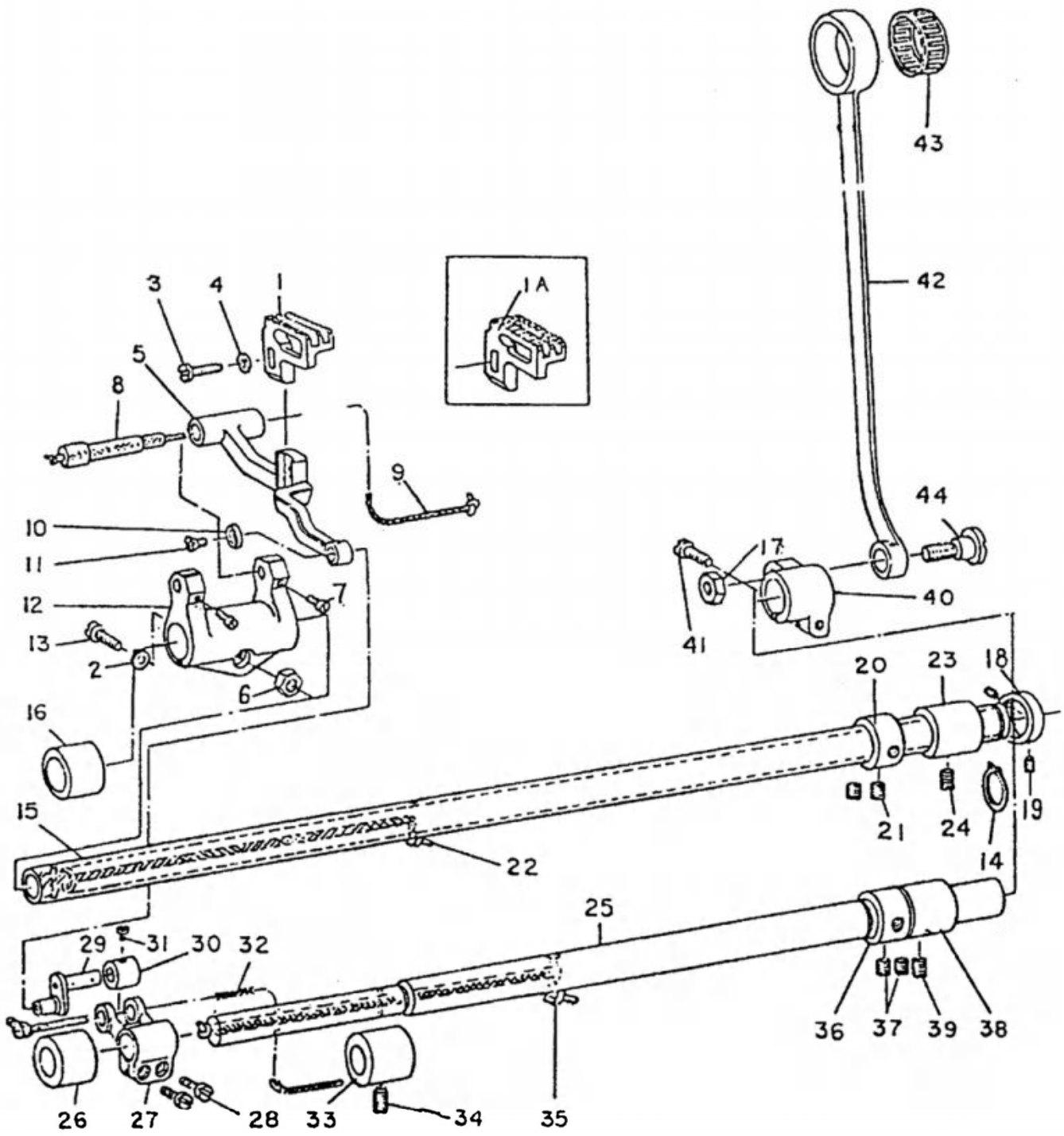

FEED & FEED LIFTING MECHANISM

No.	Part Number	Description	Q' ty	Remarks
1	5S4-07	Feed dog	1	
2	5S4-08	Washer	1	
3	5S4-09	Screw	1	
4	5S4-08	Washer	1	
5	5S4-02	Feed bar	1	
6	5S4-21H3	Nut	1	
7	6A1-08	Screw	2	
8	5S4-37P1	Crank shaft	1	
9	5S4-37P2	Oil wick	1	
10	5S4-06	Washer	1	
11	5S4-05	Screw	1	
12	5S4-36N2	Crank	1	
13	5S4-36N1	Screw	1	
14	GB894	Stop ring 15	1	
15	5S4-50S1	Feed rock shaft	1	
16	5S4-35	Front bushing	1	
17	5S4-43	Nut	1	
18	5S4-25J1	Narrow collar	1	
19	J0.068	Screw	2	
20	5S4-40Q1	Stop ring	1	
21	22T2-00B2	Screw	2	
22	5S4-5S2	Oil wick	1	
23	5S4-44	Back bushing	1	
24	J0.081	Screw	1	
25	5S4-39	Feed lifting rock shaft	1	
26	5S4-10	Front bushing	1	
27	5S4-01A1	Feed lifting crank (left)	1	
28	5S4-01A2	Screw	2	
29	5S4-03B1	Feed lifting link	1	
30	5S4-04C1	Stop ring	1	
31	5S4-04C2	Screw	2	
32	5S4-03B2	Oil wick	1	
33	5S4-10	Front bushing	1	
34	J0.040	Screw	1	
35	5S4-38	Oil wick	1	
36	5S4-40Q1	Stop ring	1	

FEED & FEED LIFTING MECHANISM

No.	Part Number	Description	Q' ty	Remarks
37	22T3-002B2	Screw	2	
38	5S4-44	Back bushing	1	
39	J0.081	Screw	1	
40	5S4-17F1	Feed lifting crank (right)	1	
41	61-04-01/B5	Screw	1	
42	5S4-19	Feed lifting connecting rod	1	
43	9241/24	Bearing	1	
44	5S4-42	Pin	1	
1A	5S4-07-3	Feed dog	1	Tandem

LOOPER MECHANISM

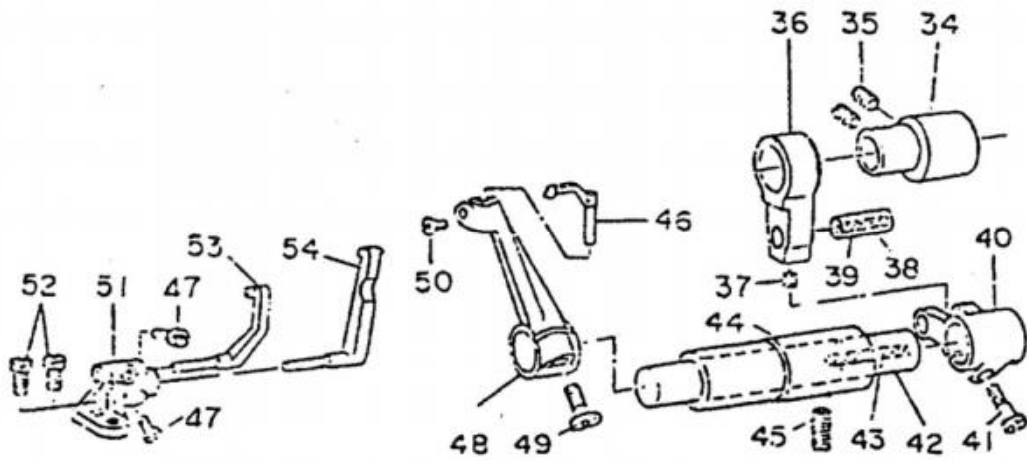
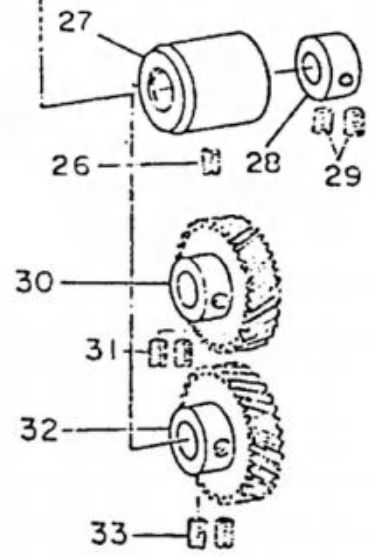
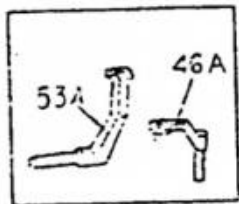
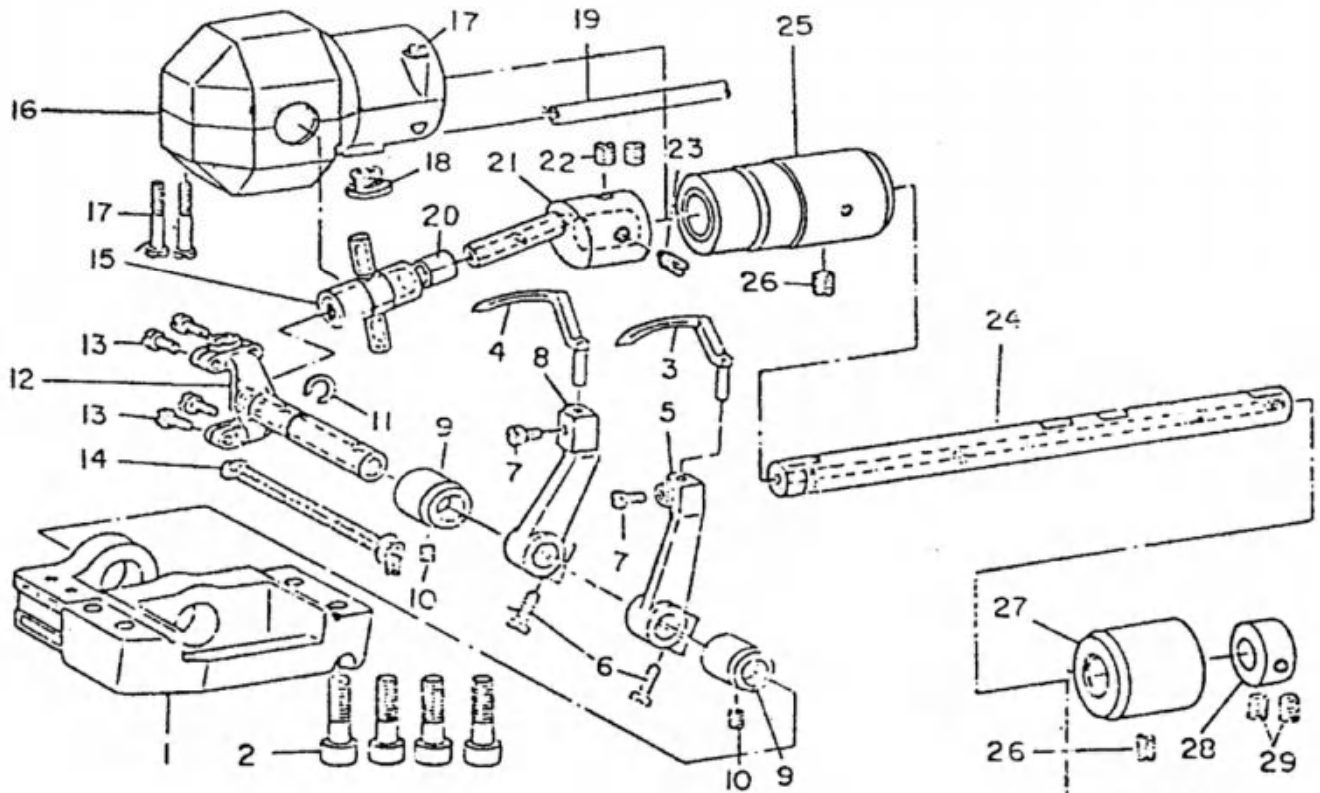

LOOPER MECHANISM

No.	Part Number	Description	Q' ty	Remarks
1	5S5-01	Looper base	1	
2	5S5-02	Screw	4	
3	5S5-30	Left looper	1	
4	5S5-31	Right looper	1	
5	5S5-28	Left looper bracket	1	
6	J0. 0. 71	Screw	2	
7	61-04-01/B3	Screw	2	
8	5S5-29	Right looper bracket	1	
9	5S5-04	Bushing	2	
10	61-04-01/B4/Z1	Screw	2	
11	GB894-2-86	Stop ring	1	
12	5S5-03A	Half shaft assy.	1	
13	6A2-23	Screw	4	
14		Yarn braid	1	
15	5S5-07	Cross joint	1	
16	5S5-05B	Looper crank housing assy.	1	
17	5S5-05B2	Screw	3	
18	22T1-003C4	Rubber plug	1	
19		Oil returning pipe	1	
20	5S5-08	Bushing	2	
21	5S5-09	Looper crank	1	
22	6A6-08A	Screw	2	
23	5S5-10	Eccentric stud	1	
24	5S5-11	Looper driving shaft	1	
25	5S5-12	Front bushing	1	
26	61-04-01/B9	Screw	2	
27	5S5-13	Back bushing	1	
28	5S5-14	Collar	1	
29	6A6-08A	Screw	2	
30	5S5-20	Left turn gear	1	
31	6A6-08A	Screw	2	
32	5S5-19	Right turn gear	1	
33	6A6-08A	Screw	2	
34	5A5-18	Needle protecting cam	1	
35	6A6-08A	Screw	2	
36	5S5-17	Needle protecting crank	1	

LOOPER MECHANISM

No.	Part Number	Description	Q' ty	Remarks
37	61-04-01/B4/Z1	Screw	1	
38	5S5-16	Pin	1	
39		Yarn braid	1	
40	5S5-15	Fork crank	1	
41	22T6-008D3	Screw	1	
42	5S5-22	Needle protecting shaft	1	
43		Yarn braid	1	
44	5S5-21	Bushing	1	
45	61-04-01/B3	Screw	1	
46	5S5-24	Movable needle protecting lever	1	
47	61-04-01/B3	Screw	2	
48	5S5-23	Needle protecting bracket	1	
49	22T6-001A16	Screw	1	
50	J0. 0. 42	Screw	1	
51	5S5-27	Needle protecting base	1	
52	22T2-019	Screw	2	
53	5S5-25	Needle protecting lever (left)	1	
54	5S5-26	Needle protecting lever (right)	1	
46A	5S5-24-3	Needle guard block	1	Tandem
53A	5S5-25-3	Needle guard block	1	Tandem

THREAD TENSION MECHANISM

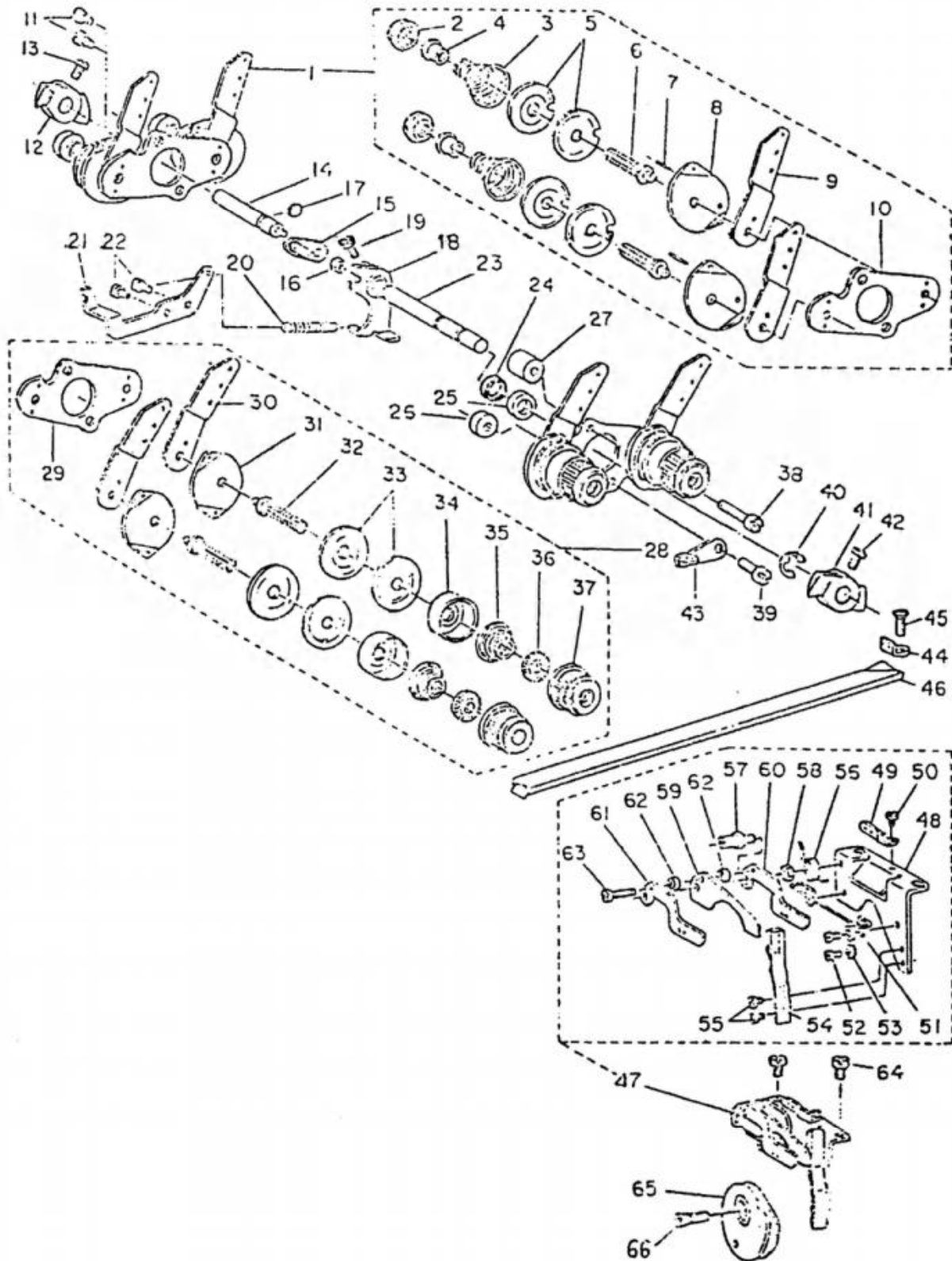

THREAD TENSION MECHANISM

No.	Part Number	Description	Q' ty	Remarks
1	5S6-01A	Rear thread tension assy.	1	
2	5S6-01A8	Tension nut	2	
3	5S6-01A6	Tension spring	2	
4	5S6-01A7	Retaining ring	2	
5	5S6-01A5	Tension disc	4	
6	5S6-01A1	Tension stud	2	
7	GB879-86	Pin	2	
8	5S6-01A4a1	Eyed thread guide plate	2	
9	5S6-01A3	3-eyed thread guide plate (rear)	2	
10	5S6-01A2	Installation plate	1	
11	36T5-008E5	Screw	2	
12	5S6-02	Thread releasing cam (rear)	1	
13	6A3-18	Screw	1	
14	5S6-03B1	Thread releasing stud (rear)	1	
15	5S6-03B2, B4	Thread releasing pin (rear)	1	
16	5S6-03B3	Nut	1	
17	GB3452.1-82	O-ring	1	
18	5S6-04C2	Thread releasing fork	1	
19	36T5-008E5H01	Screw	1	
20	5S6-15	Spring	1	
21	5S6-14	Suspension lever	1	
22	22T1-004	Screw	2	
23	5S6-05	Shaft	1	
24	GB3452.1-82	O-ring	1	
25	5S6-10	Bushing	1	
26	5S6-06	Bushing	1	
27	5S6-08	Bushing	1	
28	5S6-13D	Front thread tension assy.	1	
29	5S6-01A2	Installation plate	1	
30	5S6-13D1	3-eyed thread guide plate (front)	2	
31	5S6-13D2	Thread guide plate	2	
32	5S6-01A1	Tension stud	2	
33	5S6-13D3	Tension disc	4	
34	5S6-13D4	Tension spring cap	2	
35	5S6-13D5	Tension spring	2	
36	5S6-13D6	Retaining ring	2	

THREAD TENSION MECHANISM

No.	Part Number	Description	Q' ty	Remarks
37	5S6-13D7a	Tension nut	2	
38	5S6-09	Screw	1	
39	5S6-07	Screw	1	
40	5S6-11	Spring stop ring	1	
41	5S6-12	Thread releasing cam (front)	1	
42	6A3-18	Screw	1	
43	5S1-21	2-eyed thread guide	1	
44	5S6-16	Thread guide at bed	1	
45	5S6-17	Screw	1	
46	5S6-18	Thread guide trough	1	
47	5S6-21F	Thread releasing bracket assy.	1	
48	5S6-21F9	Thread guide plate (big)	1	
49	5S6-21F7	Thread guide plate (small)	1	
50	5S6-21F8	Screw	1	
51	5S6-21F10	Spring	1	
52	6A2-14	Screw	2	
53	GB97.2-85	Washer 3A	2	
54	5S6-21F11	Spring plate	1	
55	5S6-21F8	Screw	2	
56	5S6-21F6	Spring	1	
57	5S6-21F3	Screw	1	
58	5S6-03B3	Nut	1	
59	5S6-21F4	Thread retaining plate	1	
60	5S6-21F5	Thread guide (right)	1	
61	5S6-21F1	Thread guide (left)	1	
62	5S6-21F1	Bushing	2	
63	22T8-004	Screw	1	
64	N3-7-27	Screw	2	
65	5S6-20E	Thread releasing cam assy. (lower)	1	
66	5S6-19	Screw	1	

LUBRICATION MECHANISM

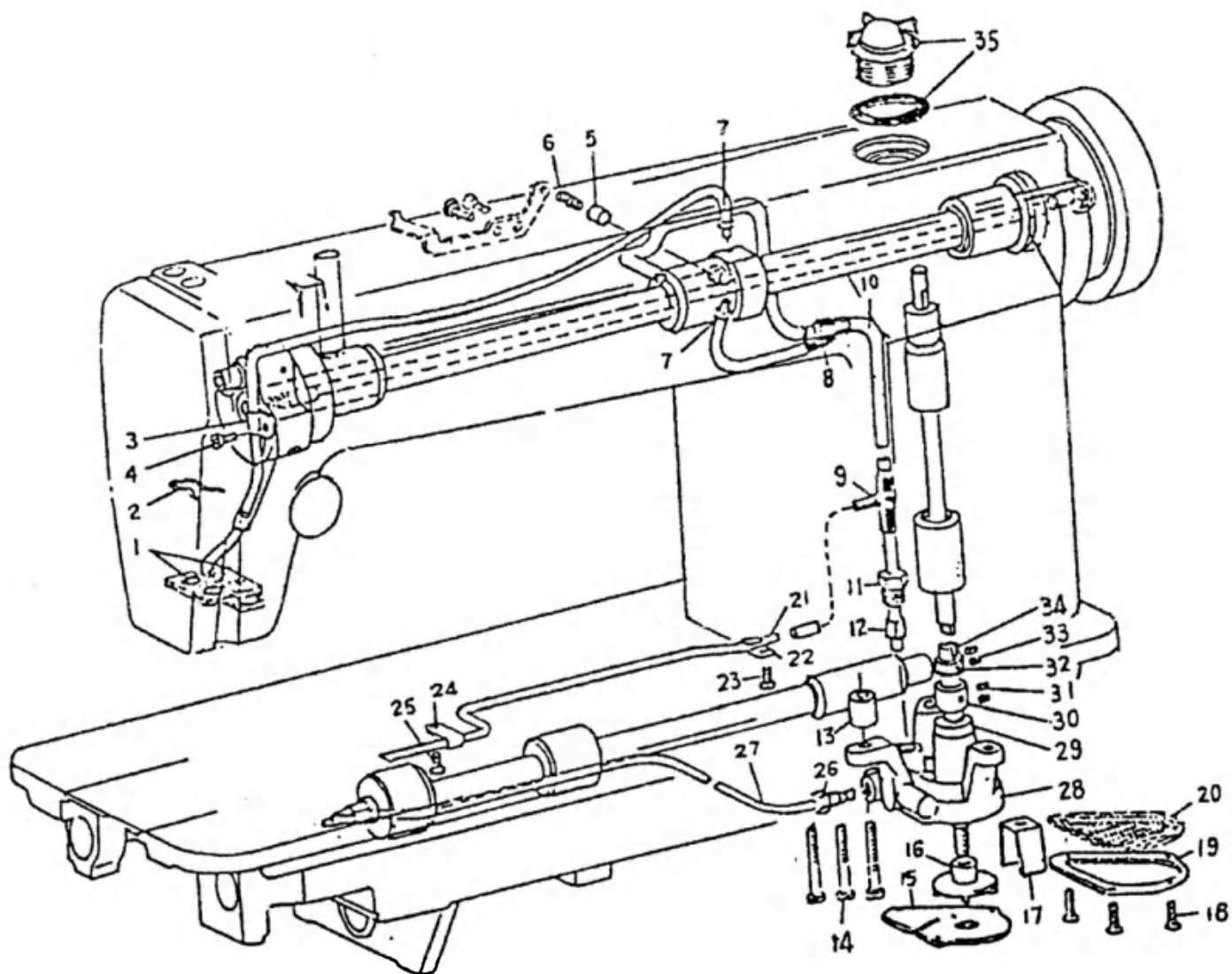

LUBRICATION MECHANISM

No.	Part Number	Description	Q' ty	Remarks
1	5S7-01A3, A4	Felt	1	
2	5S7-05	Spring	1	
3	5S7-01A2	Oil sucking tube support	1	
4	36T5-008E5	Screw	1	
5	5S7-09	Pin	1	
6	5S7-08	Spring	1	
7	5S7-06	Joint	2	
8	5S7-07	Oil tube sleeve	1	
9	5S7-10A	Oil tube sleeve	1	
10	5S7-10	Main oil tube	1	
11	5S7-17E1	Nut	1	
12	5S7-17E2	Bush	1	
13	5S7-13	Bushing	3	
14	5S7-14	Screw	3	
15	5S7-22	Oil pump screen bracket	1	
16	5S7-18	Impeller	1	
17	5S7-23	Oil pump cover	1	
18	22T8-004	Screw	3	
19	5S7-21	Oil pump fitting plate	1	
20	5S7-20	Oil pump screen	1	
21	5S7-02	Oil tube	1	
22	5S7-04	Tube clamp	1	
23	36T5-008E5	Screw	1	
24	5S7-04	Tube clamp	1	
25	36T5-008E5	Screw	1	
26	5S7-03B2	Joint	1	
27	5S7-03B1	Oil tube	1	
28	5S7-19	Oil pump	1	
29	5S7-16	Bushing	1	
30	5S7-15D1	Collar (big)	1	
31	61-04-01/B4/E1	Screw	2	
32	5S7-12C	Collar (small)	1	
33	6A4-007B	Screw	2	
34	5S7-11	Oil pump shaft	1	
35	22T1-008H	Oil check window assy.	1	

OIL PAN MECHANISM

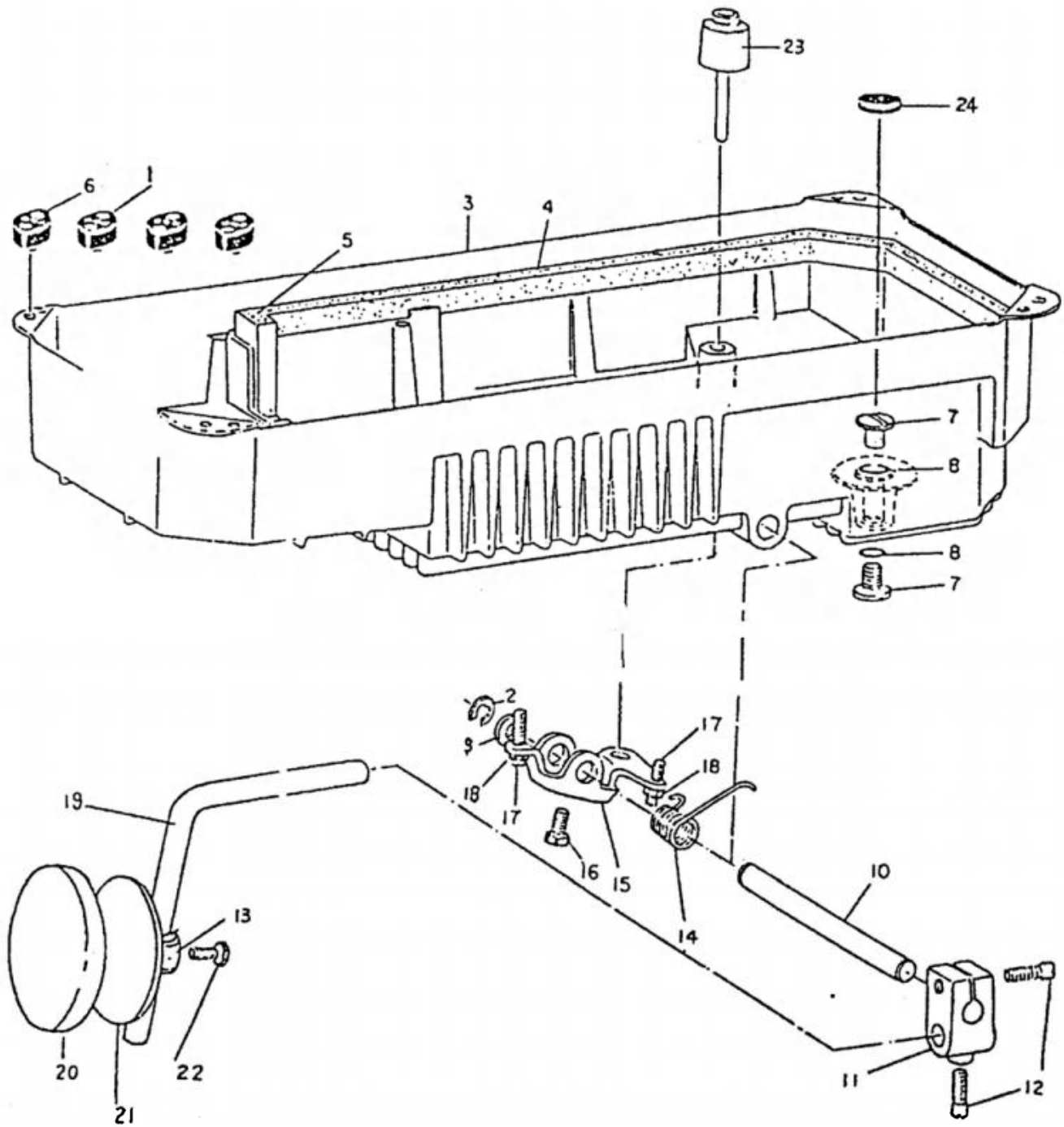

OIL PAN MECHANISM

No.	Part Number	Description	Q' ty	Remarks
1	22T9-010	Rubber cushion (small)	2	
2	GB894-76	Stop ring 11	1	
3	5S8-1	Oil pan	1	
4	5S8-2	Gasket (A)	2	
5	5S8-7	Gasket (B)	1	
6	22T9-009	Rubber cushion (big)	2	
7	5S8-5	Screw	2	
8	GB3452.1-82	O-ring	2	
9	GB95-85	Washer 10	1	
10	5S8-3	Hinge bar	1	
11	22T9-003B3	Joint	1	
12	22T9-003B4	Screw	2	
13	22T9-003B6	Bell crank bracket	1	
14	5S8-6	Spring	1	
15	22T9-001A8	Knee lifter stop bracket	1	
16	36T7-008D2	Screw	1	
17	22T9-001A9	Adjusting screw	2	
18	22T9-001A10	Nut	2	
19	22T9-003B2	Bell crank	1	
20	22T9-003B8	Pad	1	
21	22T9-003B5	Knee press plate	1	
22	22T9-003B7	Screw	1	
23	22T9-003B1	Lifting rod	1	
24	5S8-4	Magnet	1	

BELT GUARD & HEMMER DEVICE

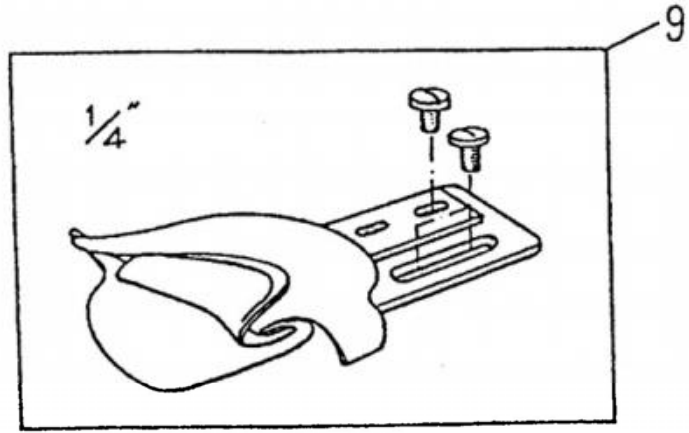
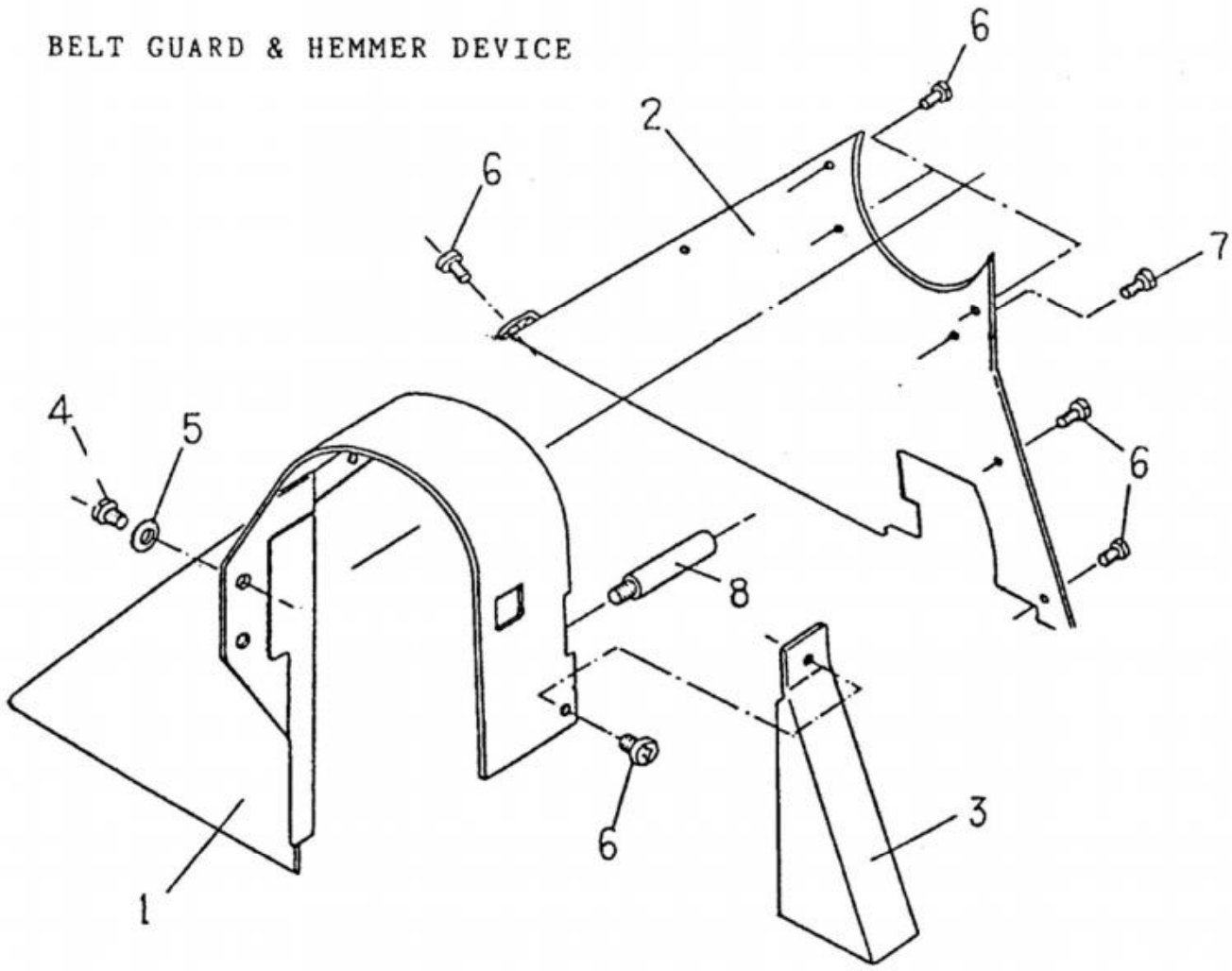

BELT GUARD & HEMMER DEVICE

No.	Part Number	Description	Q' ty	Remarks
1	5S10-1	Belt cover (big)	1	
2	5S10-2	Belt cover (middle)	1	
3	5S10-3	Belt cover (small)	1	
4	22T5-010D4	Set screw	1	
5	GB848-85	Washer	1	
6	22T2-004	Screw	7	
7	22T2-019	Screw	1	
8	5S10-4	Stud	1	
9	5S11	Hemmer 1/4"	1	

SHANGHAI BIAOZHUN HAILING SEWING MACHINERY CO., LTD.

ADD: NO.850 Shulin Road, Songjiang District Shanghai, P.R.China

Zip Code: 201612

Overseas Business: TEL: 86-21-64853303 FAX: 86-21-64854304

E-mail:sales@highlead.com.cn <http://www.highlead.com.cn>

The description covered in this manual is subject to change for improvement of the commodity without notice

2018.4. Printed