

HIGHLEAD

GC24528-B

**Post-bed Twin-Needle High Speed Split Needle
Bar Lockstitch Sewing Machine**

**Instruction Manual
Parts Catalog**

SHANGHAI HUIGONG NO.3 SEWING MACHINE FACTORY

----- CONTENTS -----

Preparation for operation	1
1. Safety precautions	1
2. Precaution before Starting Operation	1
3. Precaution for Operating Conditions	1
Cautions on use	1
1. Lubrication (1)	1
2. Lubrication (2)	1
3. Condition of oil lubrication	2
4. Cautions on operation	2
Operation	2
1. How to attach needle	2
2. How to wind the lower thread	2
3. Selection of Thread	2
4. How to route the upper thread	3
5. Adjustment of stitch length and reverse sewing	3
6. Setting bobbin	3
7. Threading of bobbin thread	4
8. Balance of thread tension	4
9. Lower thread tension	4
10. Upper thread tension	4
11. Adjustment of pressure of presser foot	4
12. Timing between rotating hook motion and needle motion	4
13. Adjustment of Feed dog height	5
14. Adjustment the needle stop position	5
15. Needle bar stop position (left & right)	5
16. Installation of Belt covers	6
Specifications	6
PARTS LIST	7

Preparation for operation:

1. Safety precautions:

- 1) When turning the power on, keep your hands and fingers away from the area around/under the needle and the area around the pulley.
- 2) Power must be turned off when the machine is not in use, or when the operator leaves the seat.
- 3) Power must be turned off when tilting the machine head, installing or removing the “V” belt, adjusting the machine, or when replacing.
- 4) Avoid placing fingers, hairs, bars etc. near the pulley, “V” belt, bobbin winder pulley, or motor when the machine is in operation.
- 5) Do not insert fingers into the thread take-up cover, under/around the needle, or pulley when the machine is in operation.
- 6) If a belt cover, finger guard, eye guard are installed, do not operate the machine without these safety devices.

2. Precautions before starting operation:

- 1) Never operate the machine before filling the machine’s oil pan.
- 2) When a new sewing machine is first turned on, verify the rotational direction of the pulley with the power on.
- 3) Verify the voltage and phase (single or three) with those given on the machine nameplate.

3. Precautions for operating conditions:

- 1) Avoid using the machine at abnormally high temperatures (35°C or higher) or low temperatures (5°C or lower) .
- 2) Avoid using the machine in dusty conditions.

Cautions on use:

1. Lubrication (1) (Fig.1)

Pour oil up to position “H” of the oil tank. During operation, check the oil level periodically, and in cases where the oil level is below position “L”, replenish the oil supply up to position “H”.

Use white spindle oil.

2. Lubrication (2) (Fig.2)

When a new sewing machine is used for the first time, or sewing machine left out of use for a long time is used again, replenish a suitable amount of oil to the portions indicated by arrow in the fig.

Note: Lubricate the Hook Base everyday.

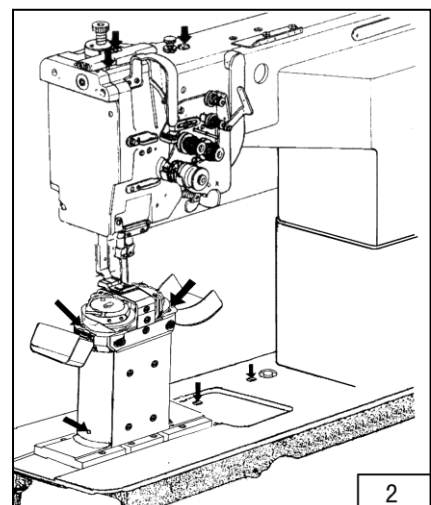
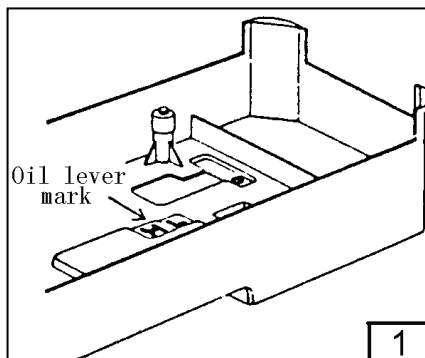

3. Condition of oil lubrication (Fig.3) :

While operating the machine, check the condition of oil lubrication through the oil check window.

4. Cautions on operation

- 1) When the power is turned on or off, keep foot away from the pedal.
- 2) It should be noted that the brake might not work when the power is interrupted or power failure occurs during sewing machine operation.
- 3) Periodical by clean the machine.

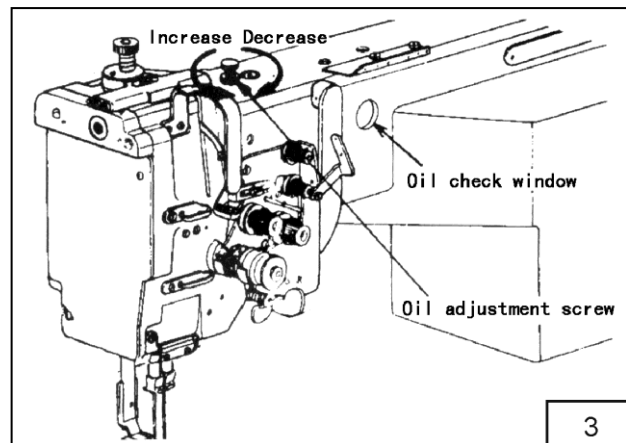

Operation

1. How to attach needle (Fig.4) :

Note: Before attach needle, be sure to turn off the power.

Loosen the needle clamping screw; Hold the needles so that the two needles side with the long grooved (faces each other), and insert it as deeply as it will go into the needle clamping holes, tighten screws.

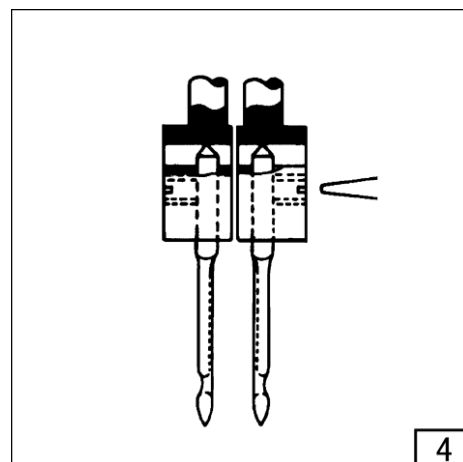

2. How to wind the lower thread (Fig.5) :

Strength of winding: Particularly in the case of nylon or polyester thread, wind the bobbin loosely.

Uneven winding: If the bobbin is wound unevenly, slide the thread guide toward the less wound portion of bobbin.

Winding amount: When the bobbin is wound excessively, loosen the adjusting screw. When the bobbin is wound insufficiently, tighten the adjusting screw.

3. Selection of Thread (Fig.6) :

It is recommended to use "S" twist thread in the left needle (Viewed from front), and "Z" twist thread in the right needle.

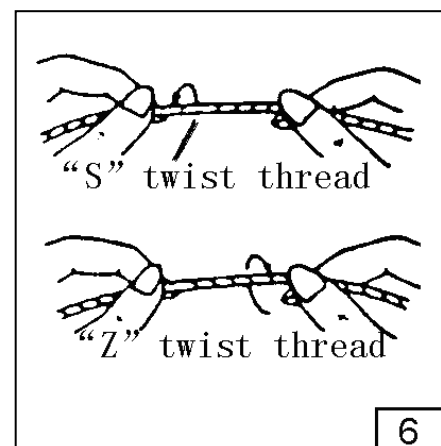
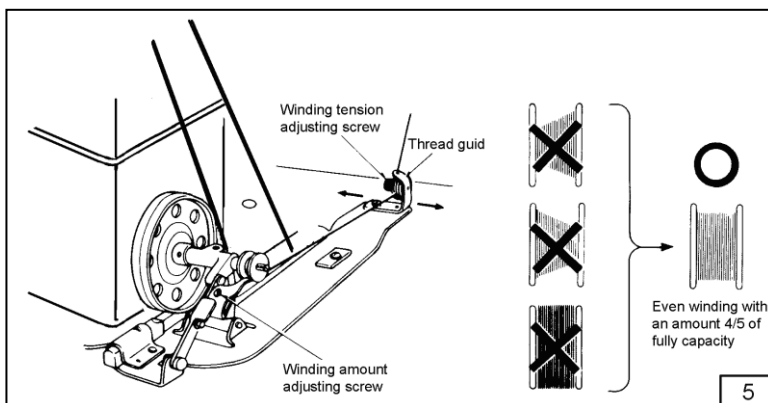

When discriminate use of needle thread is impossible, use “Z” twist thread in the needle. For bobbin thread, “S” twist thread as well as “Z” twist thread can be used.

4. How to route the upper thread (Fig.7, Fig.8) :

1) Pass each upper thread through thread guide A

Note: when thin slippery thread (polyester thread for example) is used pass the thread through thread guide B as show in Fig.7

2) With the take-up lever located at the upper most position, pass each thread in the order in Fig.8.

Note: Pressing the upper thread loosening button, the upper thread can be pulled out easily.

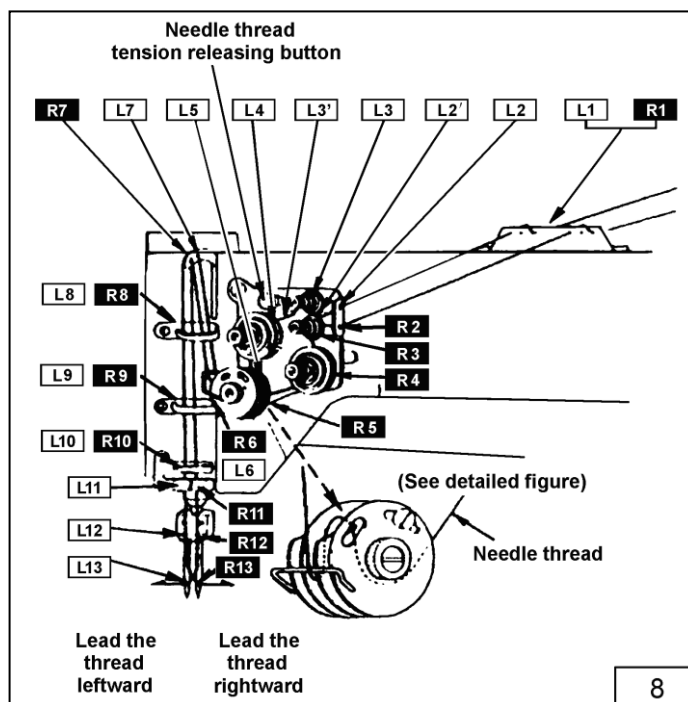
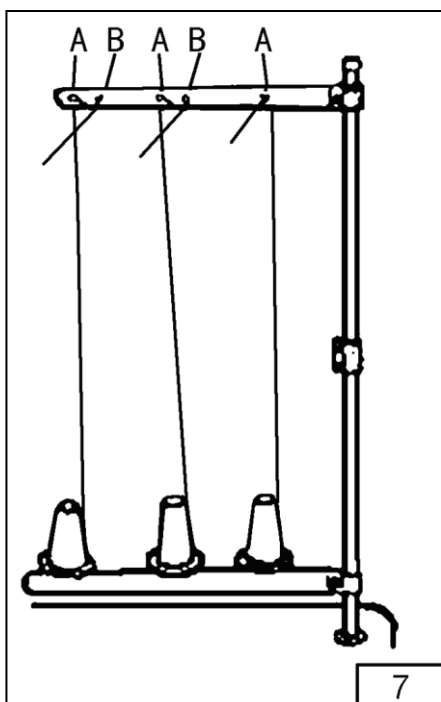

5. Adjustment of stitch length and reverse sewing (Fig.9) :

- 1) Rotate the stitch length adjusting dial to change the stitch length
- 2) Pressing the stitch length adjusting lever for reverse stitching.

6. Setting bobbin (Fig.10):

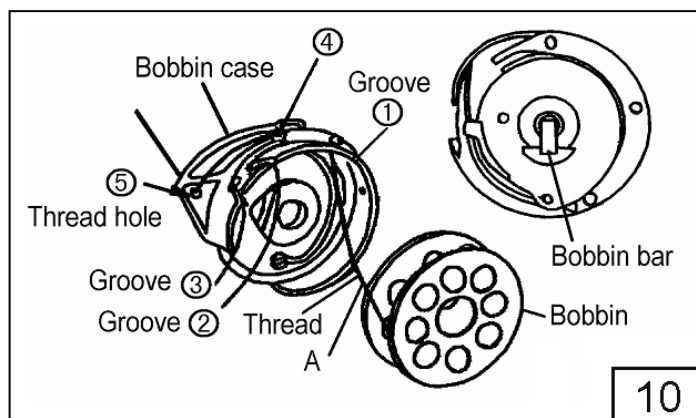
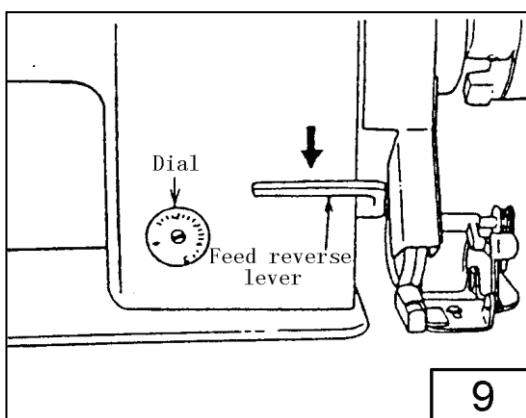

Leading the lower thread and install the bobbin

Pull out thread from side A , then install the bobbin case , Threading following ①~⑤; Put the bobbin case to rotating hook, then replace hook shaft; Press the bobbin bar, Leading the lower thread over bed plate.

7. Threading of bobbin thread (Fig.11) :

While holding the needle thread by left hand, rotate the hand wheel one turn by right hand. By pulling up the needle thread, the bobbin thread will be lifted. Close the slide plate (Fig.11)

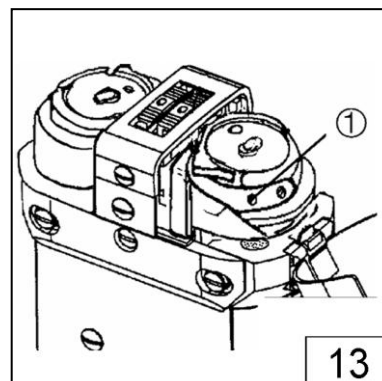
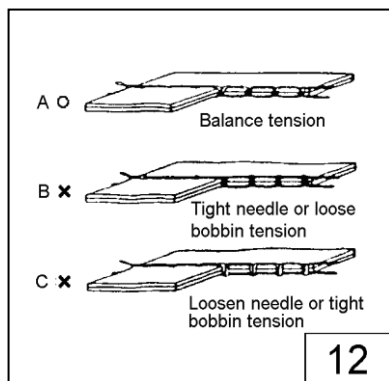
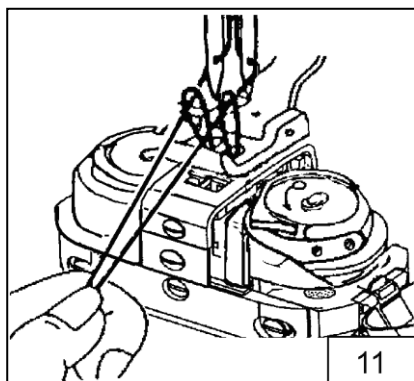

8. Balance of thread tension (Fig.12) :

9. Lower thread tension (Fig.13) :

There is virtually no need to adjust the lower thread tension, except for special kind of the fabrics or thread, when slight adjustment will be necessary.

Turning the screw 1 clockwise will increase the tension of lower thread; otherwise, the tension of lower thread will decrease. (Fig.13).

10. Upper thread tension (Fig.14) :

1) The upper thread can be adjusted based on the lower thread tension.

2) Adjustment can be done by rotating the thread tension nut.

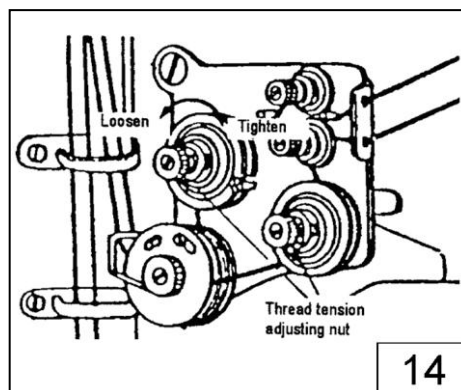

11. Adjustment of pressure of presser foot (Fig.15) :

(Fig.15) :

Pressure to fabric(s) can be adjusted by turning the pressure adjusting screw.

12. Timing between rotating hook motion and needle motion (Fig.16) :

1) Set stitch length to "6";

2) When needle is lifted 2.4mm from the lower dead point, the following position relationship should be maintained:

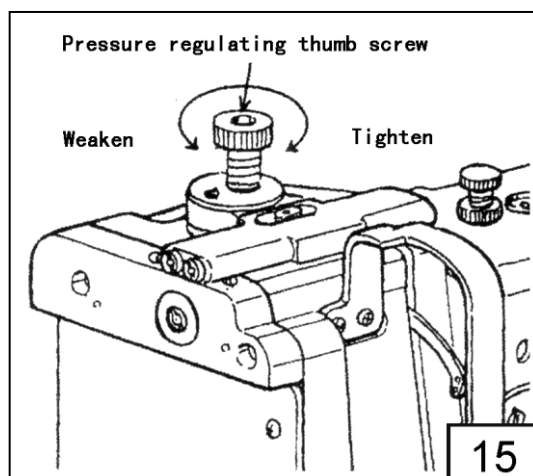

- The upper edge of needle eye should be 2.3mm below the hook point
- The hook point should be located at the center of needle axis.
- Gap between the hook point and the side face of needle should be 0.05 mm

13. Adjustment of Feed dog height (Fig.17) :

Height of feed dog should be adjusted for individual fabrics with the following cautions:

- 1) Fabric will be damaged if the feed dog extends too high or pressure of presser foot is too large
- 2) Even stitch length cannot be assured if the feed dog is too

low or pressure of presser foot is too small

- 3) Feed dog height should be measured at the point where the needle is at the top position.

For light fabric: Approx 0.8mm

For usual fabric: Approx 1.0mm

For heavy fabric: Approx 1.2mm

Adjustment procedure:

- 1) Lay down the machine bed toward the other side;
- 2) Turn the balance wheel by hand stop when the feed dog is raise to its highest position from the surface of needle place;
- 3) Loosen the Screw and adjust the height of the feed dog;
- 4) After adjusted, tighten the screw.

The feed dog height is factory-adjusted to 1.2mm

14. Adjustment the needle stop position (Fig.18):

- 1) Loosen the needle bar Screw A;
- 2) Rotate the needle clamp B one circuit (amount of Adjustment is 0.6mm), or loosen the needle bar screw C, rotate position screw D half a circuit (amount of Adjustment is 0.3mm)

- 3) Be sure to make the needle clamp facing left side, tighten needle bar screw C and A

15. Needle bar stop position (left & right) (Fig.19) :

- 1) Stop the motion of left-side needle bar:
Make the stopper wrench to the position L
- 2) Stop the motion of right-side needle bar:
Make the stopper wrench to the position R
- 3) Two needles running at the same time:
Return the needle bar of left or right from standstill to running:

Press down restore plate, stopper wrench restore to O position automatically

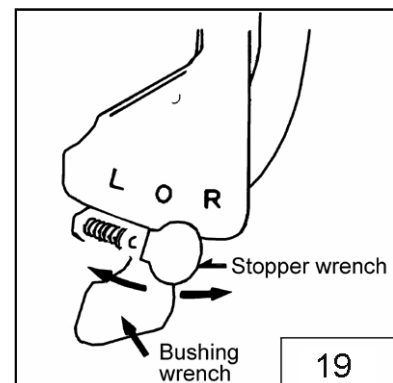
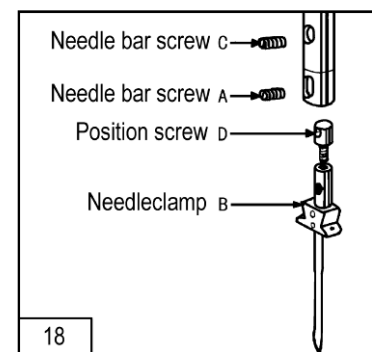
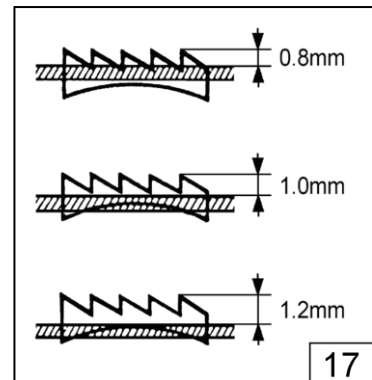
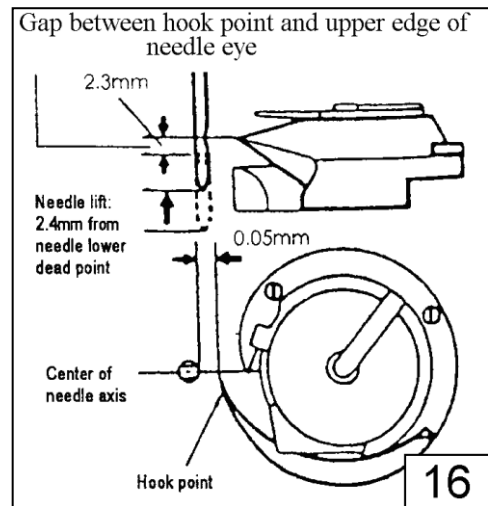

16. Installation of Belt covers (Fig.20) :

Set the screws (4、 6) and the washer (7) on the arm as illustrated. Assemble the belt guard 3 in the direction of the arrow , tighten its screw. The assembling of the belt guard 5 is the same as the belt guard 3, then , insert the belt guard 1 from the top of the pulley into the inside of the 3 and 5, tighten the screws (2) .

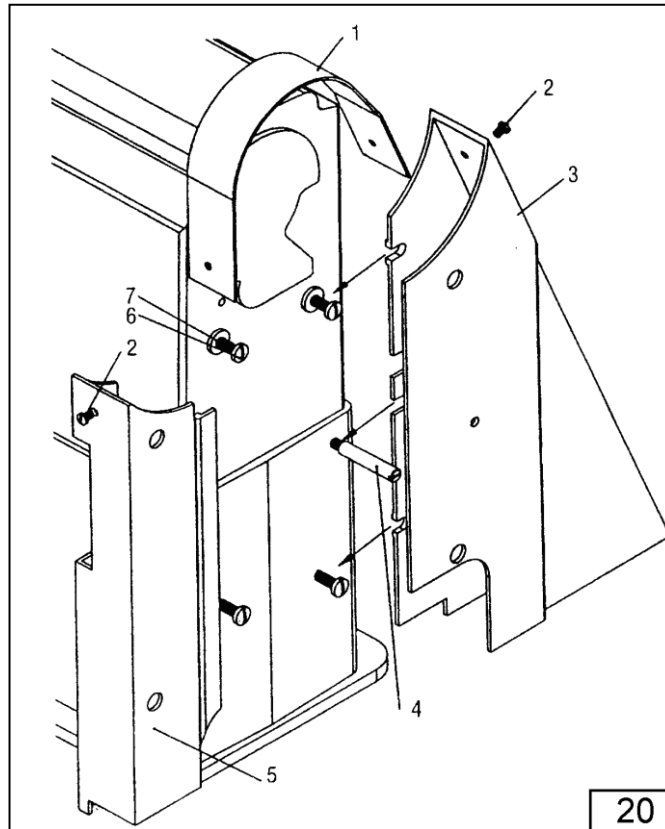

Specifications:

Model		GC24528-B
Spec		
Material weight		Medium Heavy material
Max. sewing speed		2500rpm
Stitch length		0-7mm
Needle bar stroke		33.4mm
Presser foot stroke	By hand	7mm
	By knee	13mm
Stitch-length adjusting		Dial type
Needle		DP×17 (18#--22#)
Motor		Clutch motor 370W
Needle gauge(mm)		4.8 6.4 8 9.5 12.7

A.ARM BED MECHANISM

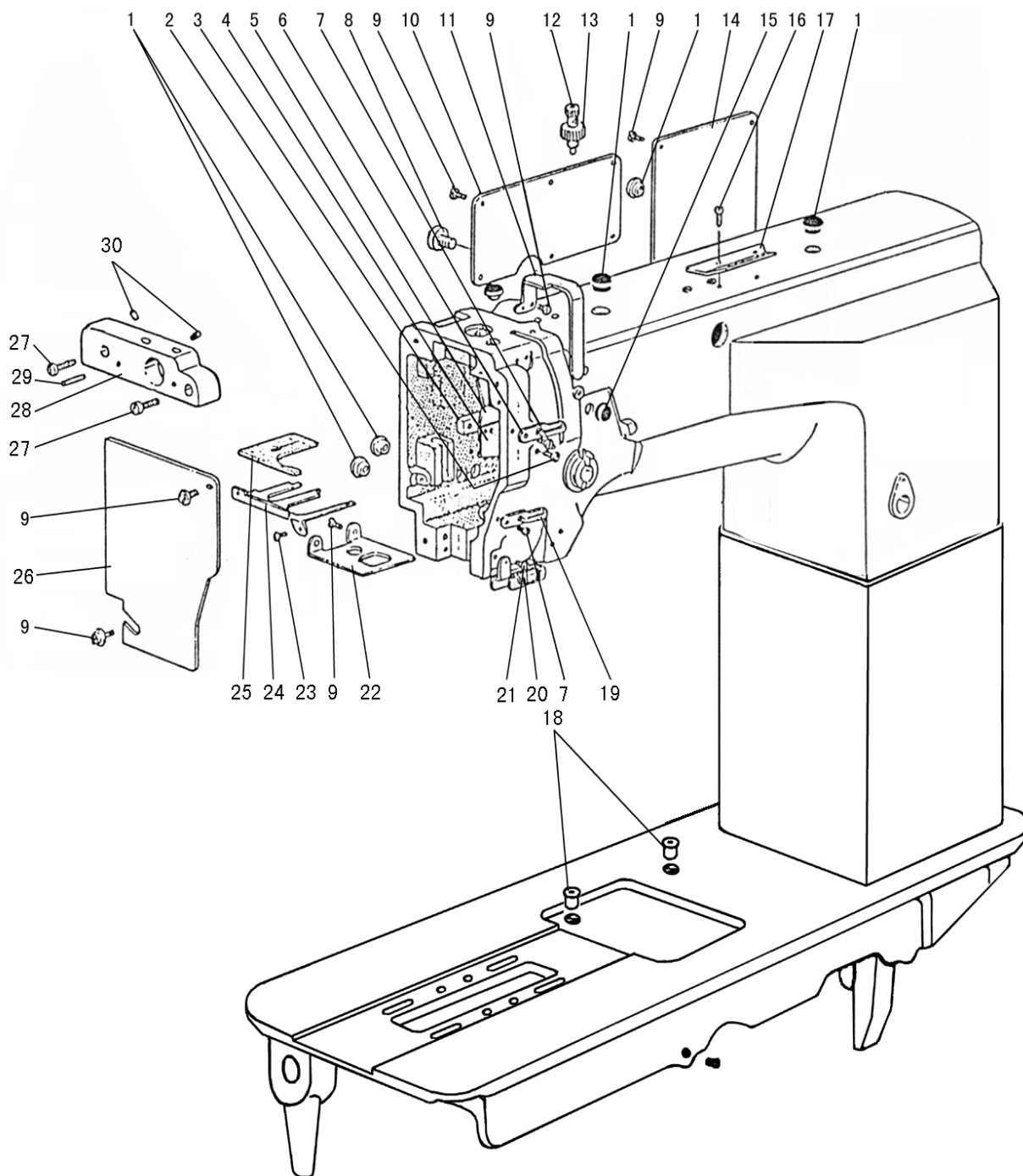

A.ARM BED MECHANISM

Fig. No.	Part No.	Description	Pcs.	Remarks
A01	H3200B2190	Rubber plug	5	
A02	H2400B2080	Screw	2	SM3/16 (28) × 11
A03	H2400B2060	Spacer	1	
A04	H3200B2060	Oil guard plate	1	
A05	H2400B2050	Oil guard plate	1	
A06	H3200B2070	Thread guide	1	
A07	H3000D2160	Screw	2	SM9/64 (40) × 6.5
A08	H409060080	Screw	1	GB/T818 M6×8
A09	HA300C2030	Screw	15	SM11/64 (40) × 8
A10	H3200B2030	Side cover (left)	1	
A11	H3200B2050	Thread take-up cover	1	
A12	H3200K0210	Thumb screw	1	M10×33
A13	H3200K0220	Special nut	1	M10×8.5
A14	H3200B2040	Side cover (right)	1	
A15	H2000B2010	Rubber plug	1	
A16	HA700B2060	Screw	2	SM11/64 (40) × 8
A17	H2400B2100	Thread guide	1	
A18	H2000M0080	Cap	2	
A19	H3200B2080	Thread guide (middle)	1	
A20	H3212B0066	Thread guide (complete)	1	
A21	H3200B2100	Screw	1	SM9/64 (40) × 6.5
A22	H3400K0020	Cover	1	
A23	H2004J0067	Screw	2	SM9/64 (40) × 7
A24	H3406K0651	Oil guard plate	1	
A25	H3406K0652	Felt	1	
A26	H3400L0030	Face plate	1	
A27	HA7311C606	Screw	2	SM11/64 (40) × 12
A28	H3400L0070	Shaft supporter	1	
A29	H602030200	Pin	2	GB/T117 3×20
A30	H2000I2080	Screw	1	SM11/64 (40) × 8

B.THREAD TENSION REGULATOR MECHANISM

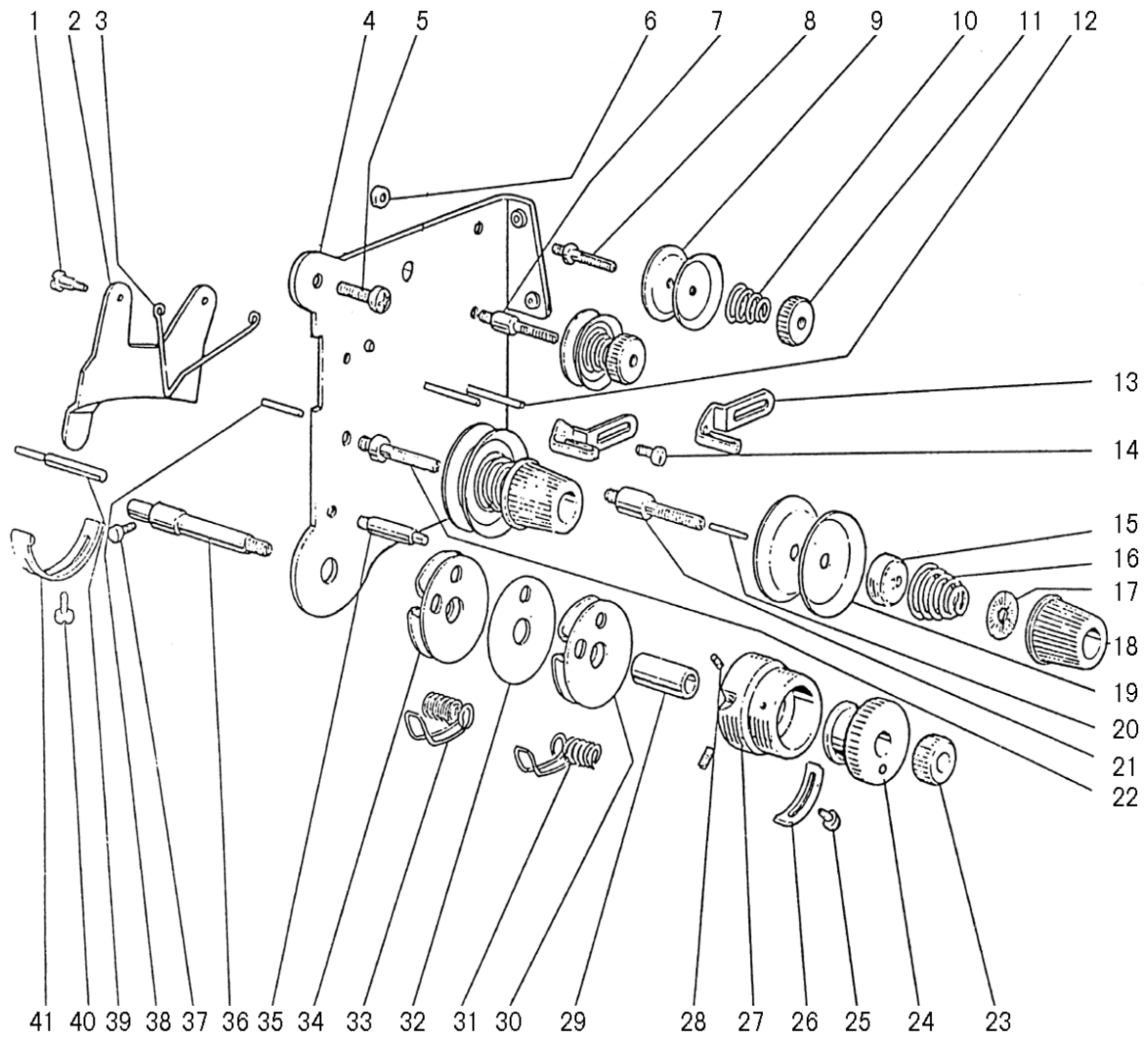

B.THREAD TENSION REGULATOR MECHANISM

Fig. No.	Part No.	Description	Pcs.	Remarks
B01	H3221B6811	Screw	2	SM9/64 (40) ×3
B02	H3221B3142	Tension releasing plate	1	
B03	H3221B6812	Tension releasing spring	1	
B04	H3221B6820	Mounting plate	1	
B05	HA300C2030	Screw	2	
B06	H3221B6810	Nut	2	SM11/64 (40)
B07	H3221B0685	Thread tension stud	1	
B08	H3221B0683	Thread tension stud	1	
B09	HA112B0693	Thread tension disk	4	
B10	H3221B0684	Thread tension spring	2	
B11	HA710B0671	Thumb nut	2	SM11/64 (40)
B12	H3221B0682	Pin	3	
B13	H3306B0661	Thread guide	1	
B14	HA106B0676	Screw	1	SM9/64 (40) ×6
B15	HA310B0702	Thread tension releasing plate	2	
B16	H3300B2040	Thread tension spring	1	
B17	HA115B7010	Thumb nut revolution stopper	2	
B18	HA310B0701	Thumb nut complete	2	
B19	HA310B0705	Thread tension disk	4	
B20	H3221B6816	Pin	1	
B21	H3221B0689	Thread tension stud	1	
B22	H3221B0686	Thread tension stud	1	
B23	H32481B721	Thumb nut	1	SM1/4 (40)
B24	H32481B621	Take-up spring guide	1	
B25	H32481BC21	Screw	1	SM9/64 (40) ×6
B26	H32481BB21	Stopper	1	
B27	H32481B921	Thread tension post	1	
B28	H32481B521	Screw	2	SM1/8 (44) ×3.9
B29	H32481B821	Bushing	1	
B30	H32481BF21	Plate complete	1	
B31	H32481B321	Thread take-up spring	1	
B32	H32481BE21	Plate	1	
B33	H32481B221	Thread take-up spring	1	
B34	H32481BD21	Plate complete	1	
B35	H32481B421	Screw	1	SM9/64 (40) ×2.9
B36	H32481B121	Thread tension stud	1	
B37	H2004J0067	Screw	1	SM9/64 (40) ×7
B38	H3221B6817	Pin	1	
B39	H3221B6818	Tension releasing pin	1	
B40	H3200B2100	Screw	1	SM9/64 (40) ×6.5
B41	H3221B6819	Stopper	1	

C.ARM SHAFT MECHANISM

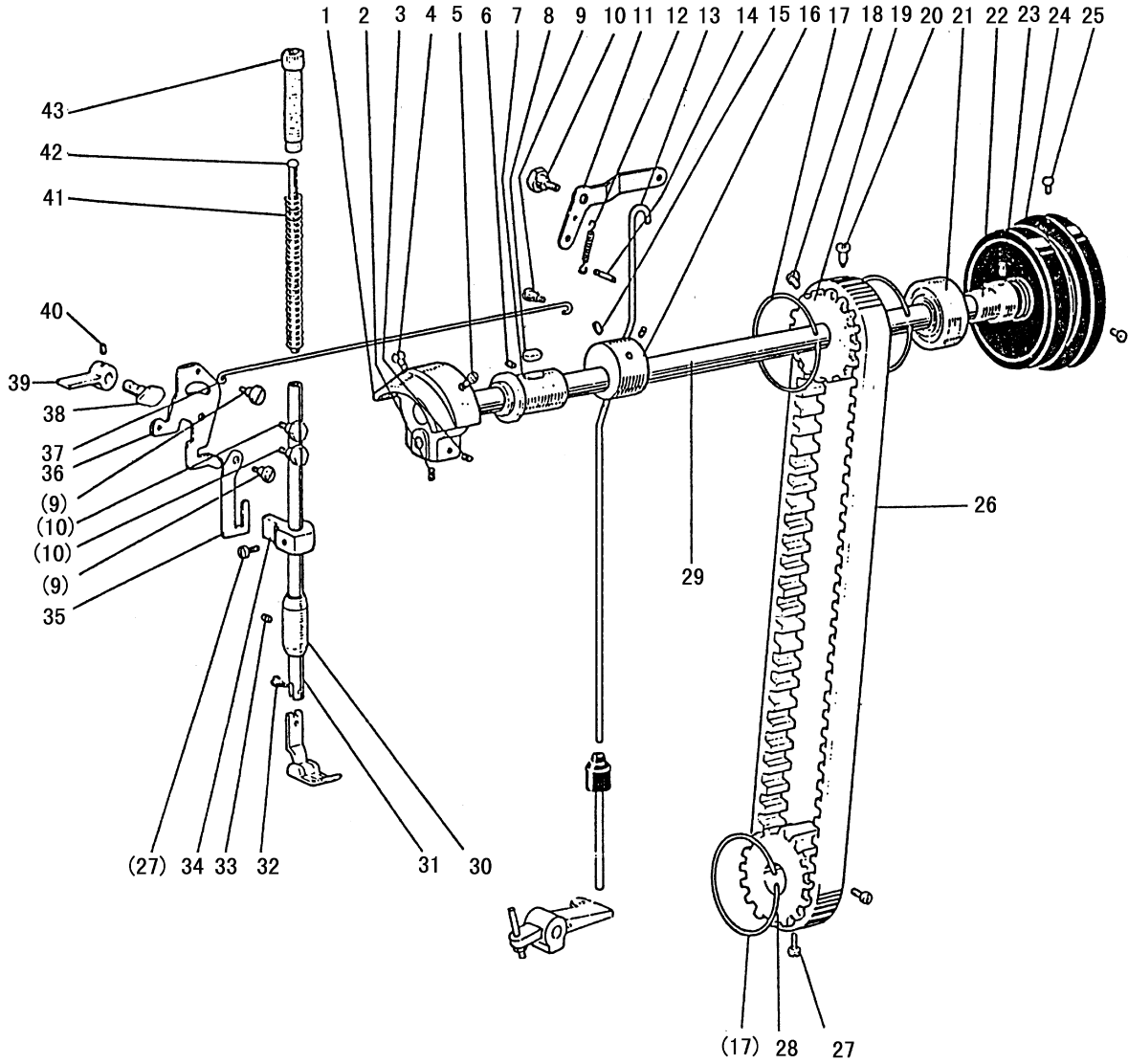

C.ARM SHAFT MECHANISM

Fig. No.	Part No.	Description	Pcs.	Remarks
C01	H3404B0011	Crank	1	
C02	HA105D0662	Screw	1	SM1/4 (40) × 3.5
C03	HA307C0662	Set screw	1	SM1/4 (40) × 7
C04	HA100C2060	Screw	1	SM9/32 (28) × 14
C05	HA100C2070	Screw	1	SM9/32 (28) × 13
C06	H2405D0664	Set screw	1	SM15/64 (28) × 14
C07	H3204B0011	Arm shaft bushing (left)	1	
C08	H32111B104	Felt	1	
C09	HA107H0662	Screw	3	SM3/16 (28) × 3.5
C10	HA100H2050	Bolt	3	SM15/64 (28) × 6.7
C11	H3211E0691	Knee lifter lever (right)	1	
C12	H3211E0692	Spring	1	
C13	H6307E8001	Knee lifter connecting rod	1	
C14	H3200E2090	Pin	1	φ 5×28
C15	HA100C2020	Screw	2	SM15/64 (28) × 10
C16	H3406B0671	Blance weight	1	
C17	H3205C0661	Spring flange	3	
C18	HA113F0684	Screw	1	SM15/64 (28) × 8.5
C19	H3205C1021	Pulley(upper)	1	
C20	HA100F2130	Screw	1	SM15/64 (28) × 14.5
C21	H3205J0662	Ball bearing	1	6204ZZNR/5K
C22	H3205J0661	Bushing	1	
C23	HA113F0684	Screw	2	SM15/64 (28) × 8.5
C24	H4100C2040	Pulley	1	
C25	HA110D0672	Screw	2	SM15/64 (28) × 12
C26	H6304C8001	Cog belt	1	
C27	HA104F0654	Screw	3	SM15/64 (28) × 10
C28	H3207C0671	Pulley(lower)	1	
C29	H3204C0651	Arm shaft	1	
C30	HA704B0651	Bushing	1	
C31	H3200E2010	Presser bar	1	
C32	H3200E2020	Screw	1	SM1/8(44) × 9
C33	HA100C2020	Screw	1	SM15/64 (28) × 10
C34	H3207E0661	Presser bar guide bracket	1	
C35	H3210E0683	Operation plate	1	
C36	H3210E0682	Knee lifter lever left	1	
C37	H3210E0681	Knee lifter rod	1	
C38	H3200E2060	Presser bar lifting cam	1	
C39	H3208E0672	Presser bar lifter	1	
C40	HA100B2110	Screw	2	SM11/64 (40) × 6.6
C41	H3200E2100	Spring	1	
C42	HA100H2120	Presser spring guide	1	
C43	HA309H0681	Screw	1	SM1/2 (28) × 49

D.NEEDLE BAR ROCKING MOTION MECHANISM

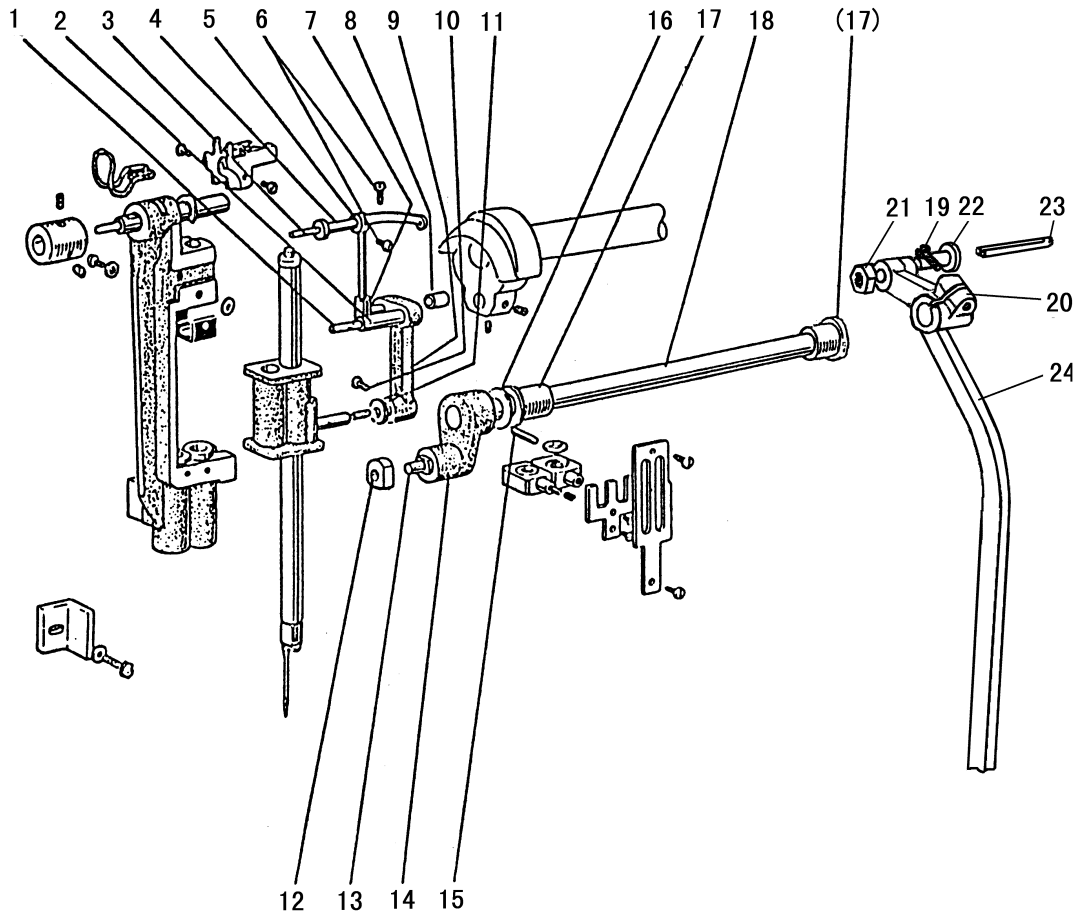

D.NEEDLE BAR ROCKING MOTION MECHANISM

Fig. No.	Part No.	Description	Pcs.	Remarks
D01	H2405D0663	Oil wick	1	ϕ 3×80
D02	H2405D0662	Needle bar crank pin	1	
D03	H2405D1122	Oil wick	1	ϕ 2.5×240
D04	H32422C108	Thread take-up guide bracket pin	1	
D05	H3504B0651	Thread take-up lever	1	
D06	HA110D0672	Screw	3	SM15/64 (28) ×12
D07	H2405D1112	Thread take-up link	1	
D08	H24211D305	Plug	1	
D09	H3409C0671	Connecting link	1	
D10	HA100H2150	Screw	1	SM9/64 (40) ×11
D11	H3409C0672	Bushing	1	
D12	H3410C301P	Square block	1	
D13	H3406C0671	Connecting stud	1	
D14	H3406C0672	Needle bar rocking shaft crank	1	
D15	H602040240	Pin	1	GB/T117 4×24
D16	H3400C2050	Washer	1	
D17	H3204B0652	Bushing	2	
D18	H3406C0673	Needle bar rocking shaft	1	
D19	H2012N0652	Screw	1	SM1/4 (24) ×16
D20	H7104F8001	Connecting crank	1	
D21	H7107F8001	Nut	1	SM5/16 (24)
D22	H7108F8001	Hinged screw	1	SM5/16 (24) ×26.2
D23	H32311D406	Oil wick	1	
D24	H0205F8001	Rocking shaft connecting rod	1	

E.NEEDLE BAR MECHANISM

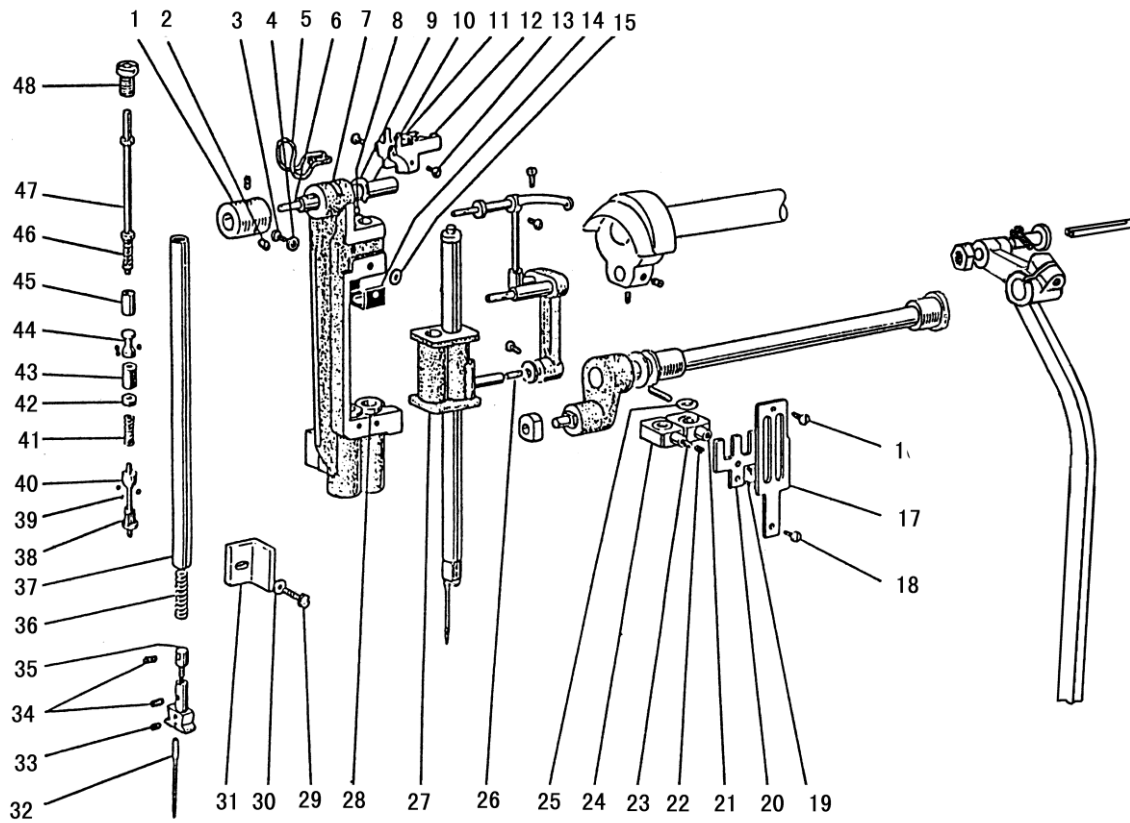

E.NEEDLE BAR MECHANISM

Fig. No.	Part No.	Description	Pcs.	Remarks
E01	H3410C3025	Bushing	1	
E02	HA305E0662	Screw	2	SM15/16 (28) × 4.5
E03	H32481BC21	Screw	1	SM9/64 (40) × 6
E04	H3410C301J	Spring	1	
E05	H3410C3010	Oil wick	1	
E06	H3410C3023	Oil wick	1	
E07	H34411C110	Needle bar supporter	1	
E08	H609030220	Pin	1	GB/T879.1 3×22
E09	H007013070	E-type stop ring	1	GB/T896 7
E10	H3410C3022	Needle bar supporter guide pin	1	
E11	H3410C301H	Holder	1	
E12	H3410C301Q	Holder	1	
E13	H3410C301L	Screw	2	SM9/64 (40) × 4
E14	H3410C301E	Stopper	1	
E15	HA703R0067	Washer	1	
E16	H3410C301K	Screw	1	SM9/64 (40) × 6.5
E17	H3410C301D	Guide plate	1	
E18	H3215K0693	Screw	1	SM9/64 (40) × 5
E19	H3410C301C	Screw	1	SM3/32 (44) × 4.2
E20	H3410C301B	Needle bar supporter	1	
E21	H3410C3015	Needle bar holder (right)	1	
E22	H3410C3019	Set screw	2	SM9/64 (40) × 3.5
E23	H3410C3018	Needle bar holding stopper	2	
E24	H3410C3017	Needle bar holder (left)	1	
E25	H3410C3016	Spacer	4	
E26	H3204D6513	Felt	1	
E27	H3410C3014	Needle bar holder	1	
E28	H34411C310	Bushing for needle bar supporter	2	
E29	H3400C2020	Bolt	1	SM11/64 (40) × 12
E30	H3200I2030	Washer	1	
E31	H3400C2010	Needle bar guide	1	
E32	JZDP1700G2102	Needle	2	DP×17#21
E33	H32481B521	Screw	1	SM1/8 (44) × 3.5
E34	H34412C710	Screw	4	SM1/8 (44) × 6
E35	H34412C910	Stopper for needle clamp	2	
E36	H34412C410	Spring	2	
E37	H34411C210	Needle bar	2	
E38	H3410C1264	Triangle pin	2	
E39	H3410C301I	Steel ball	12	Sφ 2.5
E40	H3410C1263	Stud	2	
E41	H3410C1265	Spring	2	
E42	H3410C1262	Nut	2	SM5/64 (64)
E43	H3410C1261	Nut	2	SM5/64 (64) × 6

E.NEEDLE BAR MECHANISM

Fig. No.	Part No.	Description	Pcs.	Remarks
E44	H34412C310	Pin	2	
E45	H34412C210	Sleeve	2	
E46	H34412C110	Spring	2	
E47	H34412C510	Pin	2	
E48	H34412C810	Screw	2	M5. 5×0. 5

F.NEEDLE BAR CONTROL MECHANISM

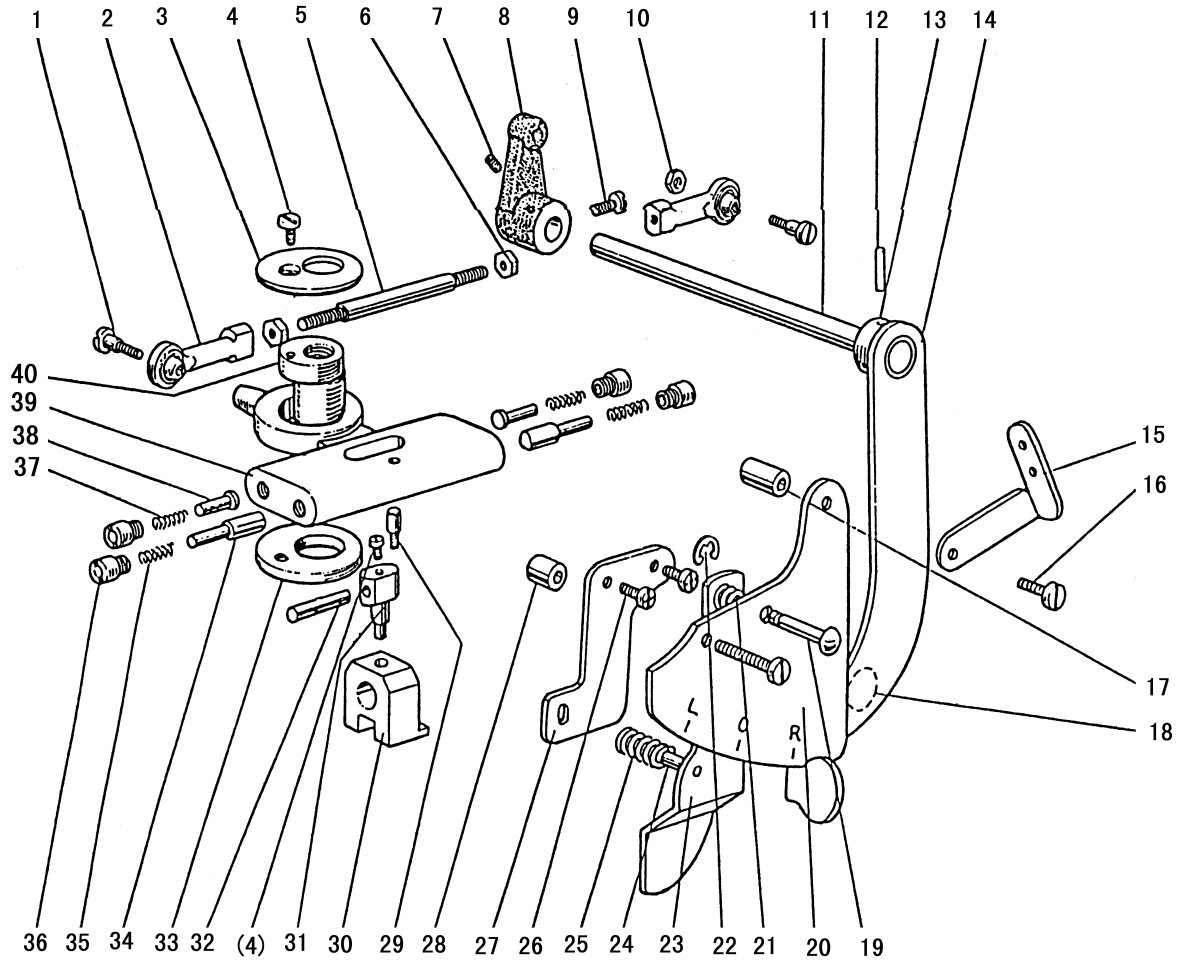

F.NEEDLE BAR CONTROL MECHANISM

Fig. No.	Part No.	Description	Pcs.	Remarks
F01	H3400D2030	Screw	2	SM11/64(40)×9.5
F02	H3405D0663	Ball joint	2	JKM5
F03	H3400D2120	Cover	1	
F04	HA7311CC06	Screw	2	SM9/64(40)×6.5
F05	H3405D0661	Connecting rod	1	
F06	H003057050	Nut	2	M5
F07	H3416D0692	Screw	1	SM11/64(40)×6.6
F08	H3416D0691	Arm	1	
F09	HA100B2110	Blot	1	SM15/64(28)×10
F10	H3221B6810	Nut	1	SM11/64(40)
F11	H34321D407	Shaft	1	
F12	H609030180	Spring pin	1	GB/T879.1 3×18
F13	H34321D207	Pinching bushing	1	
F14	H34321D107	Stop motion control lever	1	
F15	H3400L0050	Thread guide	1	
F16	H2004J0067	Screw	2	SM11/64(40)×11.4
F17	H3400D2060	Pipe	1	
F18	H3407D0671	Pin	1	
F19	H3408D0681	Pin	1	
F20	H3408D0686	Lever position plate	1	
F21	H3408D0682	Spring	1	
F22	H007013040	E type stopring	1	GB/T896 4
F23	H3408D0684	Lever	1	
F24	H3408D0685	Pin	1	
F25	H3400D2100	Spring	1	
F26	HA300C2030	Screw	2	SM11/64(40)×8
F27	H3400D2090	Plate	1	
F28	H3400D2080	Pipe	1	
F29	H3400D2110	Screw	1	SM9/64(40)×12.5
F30	H3410C3021	Cam	1	
F31	H3404D0652	Guide pin	1	
F32	H3404D0653	Pin	1	
F33	H3404L0653	Washer	1	
F34	H3404D0655	Pin	2	
F35	H3404D0657	Spring	2	
F36	H3404D0656	Cap screw	4	SM5/16(28)×4
F37	H3404D0658	Spring	2	
F38	H3404D0654	Pin	2	
F39	H3404D0651	Guide	1	
F40	H3404L0652	Bushing	1	

G.STITCH REGULATOR MECHANISM

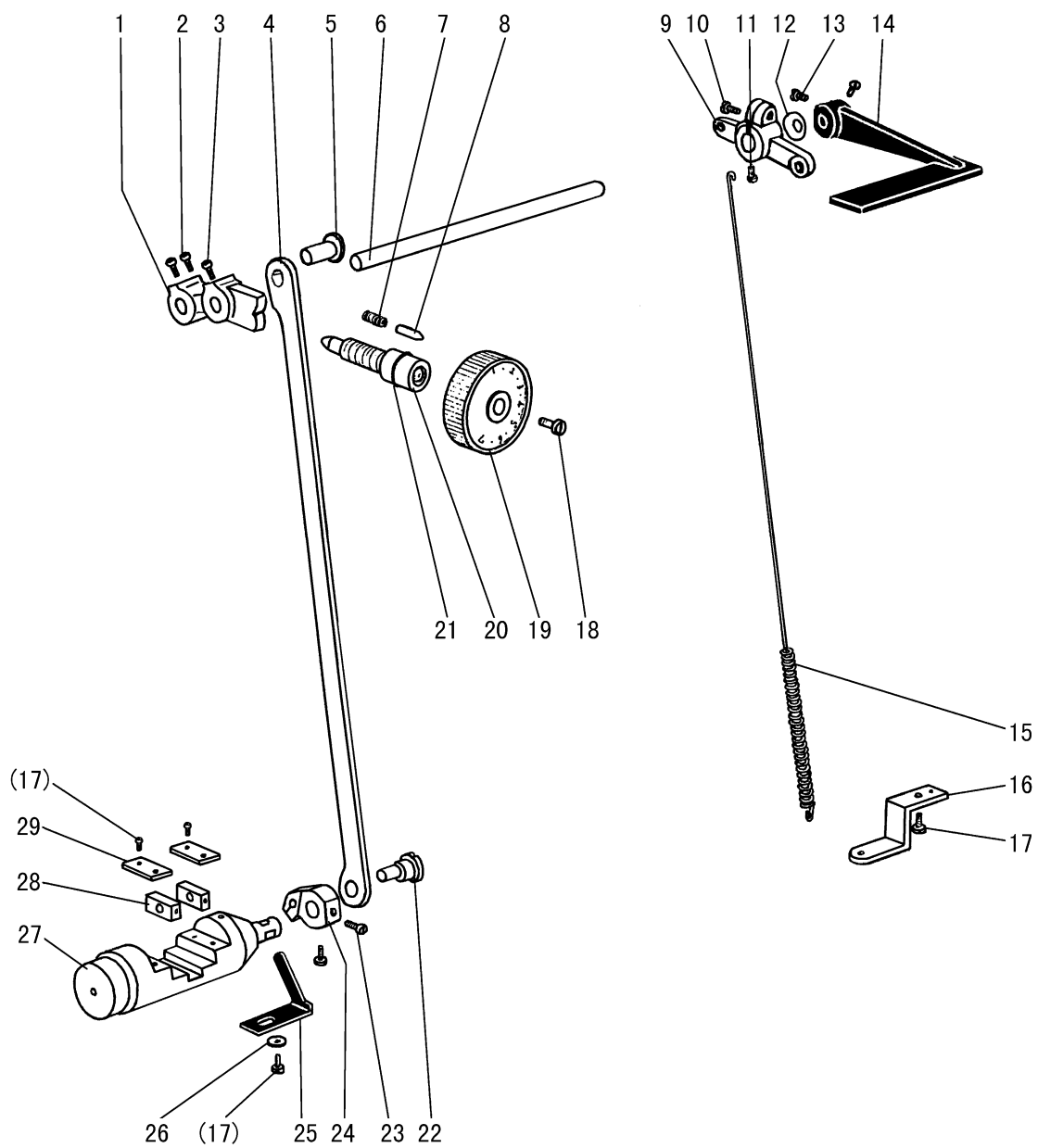

G.STITCH REGULATOR MECHANISM

Fig. No.	Part No.	Description	Pcs.	Remarks
G01	H6309F8001	Feed regulator	1	
G02	HA113F0684	Screw	2	SM15/64 (28) × 8.5
G03	H3200F2020	Screw	1	SM15/64 (28) × 12
G04	H6304F8001	Connecting link	1	
G05	HA100G2070	Eccentric shaft	1	
G06	H3200F2060	Reverse stitch shaft	1	
G07	H3200F2110	Spring	1	
G08	HA100F2080	Pin	1	
G09	H6306F8001	Arm	1	
G10	HA800F2020	Screw	1	SM15/64 (28) × 16.5
G11	H3207F0672	Screw	1	SM11/64 (40) × 8.5
G12	HA100F2110	Spring washer	1	
G13	HA113F0684	Screw	2	SM15/64 (28) × 8.5
G14	H3216F0711	Reverse sewing lever	1	
G15	H6307F8001	Spring	1	
G16	H6308F8001	Bracket for spring	1	
G17	HA300C2030	Screw	6	SM11/64 (40) × 8
G18	HA109F0673	Screw	1	SM3/6 (28) × 8
G19	H3304F0651	Dial	1	
G20	HA109F0671	Screw bar	1	SM3/16 (28) × 12
G21	HA720F0685	O-ring	1	
G22	H3206F0662	Bolt	1	SM1/4 (40) × 8
G23	H3210F0681	Screw	2	M5 × 6
G24	H3210F0683	Stitch regulating crank lower	1	
G25	H3200F2080	Holding plate of reverse bar	1	
G26	HA703R0067	Washer	1	
G27	H3212F0692	Reverse bar	1	
G28	H3208G0672	Square block	2	
G29	H3212F0691	Guide plate	2	

H.LOWER SHAFT & FEED ROCK SHAFT MECHANISM

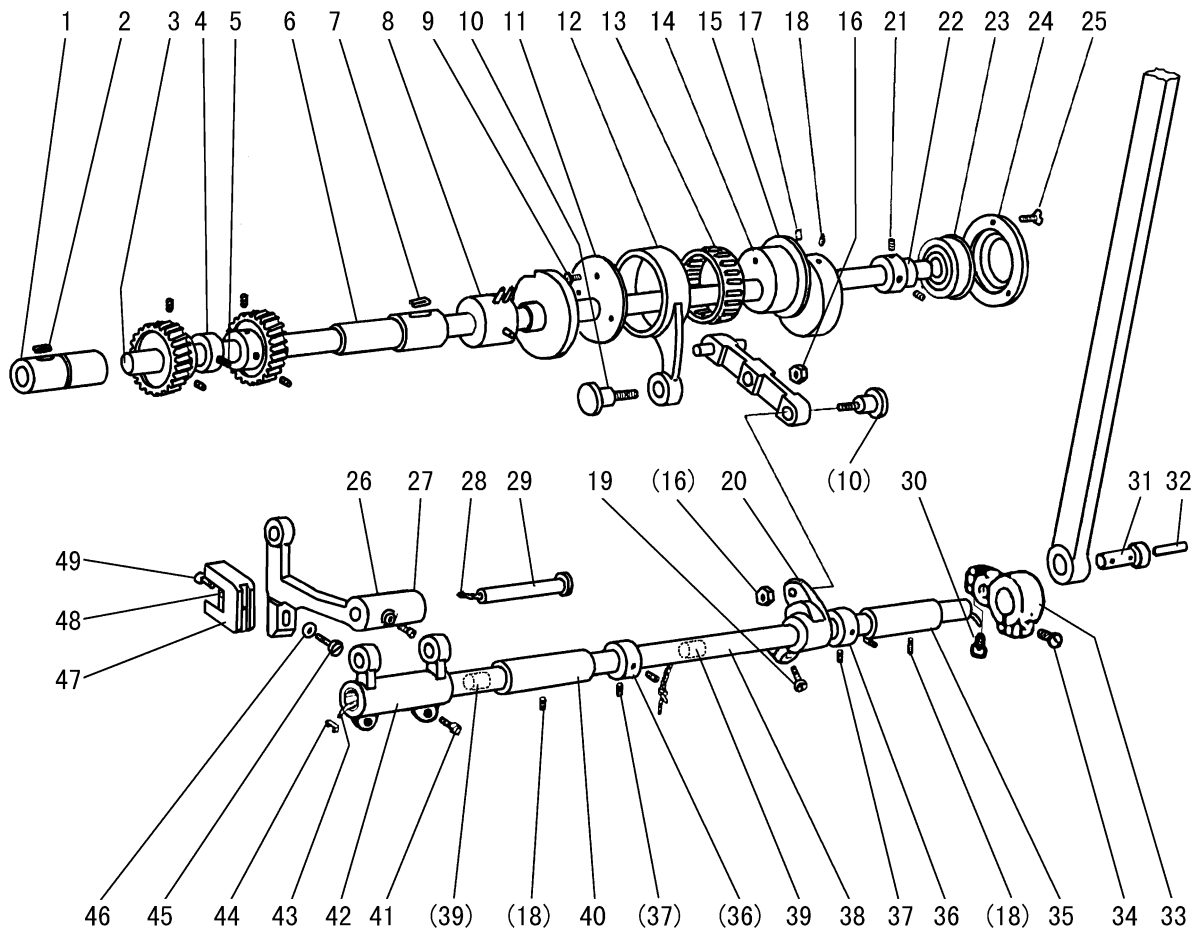

H.LOWER SHAFT & FEED ROCK SHAFT MECHANISM

Fig. No.	Part No.	Description	Pcs.	Remarks
H01	H6315B8001	Lower shaft bushing(left)	1	
H02	H32132B204	Oil wick	1	
H03	H6304H8001	Lower shaft	1	
H04	H3205H0655	Feed lifting cam	1	
H05	H3205H0654	Set screw	1	SM1/4(40)×5
H06	H6317B8001	Lower shaft bushing(right)	1	
H07	H32132B204	Oil wick	1	
H08	HH404H7101	Lower shaft bushing(middle)	1	
H09	HA700F2100	Screw	3	SM11/64 (40) × 7
H10	H3208G0674	Screw	2	SM1/4 (24) × 15
H11	H32372G208	Washer	1	
H12	H32372G408	Feed connecting rod	1	
H13	H32372G308	Needle bearing	1	
H14	H3305G1011	Lever feed connecting cam	1	
H15	H3208G2011	Link	1	
H16	H3208G0675	Nut	2	
H17	H2405D0664	Set screw	1	SM15/64 (28) × 14
H18	H3208G0676	Screw	3	SM15/64 (28) × 14
H19	H3208G0676	Screw	1	SM15/64 (28) × 14
H20	H3208G0673	Connecting rod crank(middle)	1	
H21	HA105D0662	Set screw	2	SM1/4 (40) × 4
H22	H3208H0662	Bushing	1	
H23	H3208H0661	Ball bearing	1	
H24	H3200H2060	Bearing holder	1	
H25	HA7311C306	Screw	3	SM9/64 (40) × 7
H26	H6305G8001	Feed bar	1	
H27	H429050050	Screw	1	
H28	H3205G0662	Oil wick	1	
H29	H32243G205	Feed bar shaft	1	
H30	HA104G0012	Screw	1	SM3/16 (28) × 12
H31	H3407C0664	Pin	1	
H32	H24211D405	Oil wick	1	
H33	H3407C0663	Connecting rod crank(right)	1	
H34	H2012N0652	Screw	1	SM1/4 (24) × 16
H35	H3204B0656	Feed rock shaft bushing(right)	1	
H36	HA108G0066	Collar	2	
H37	HA105D0662	Screw	4	SM1/4 (40) × 4
H38	H3204G0651	Feed rock shaft	1	
H39	H3204G0652	Felt	2	
H40	HA100G2120	Feed rock shaft bushing(left)	1	
H41	HA104G0012	Screw	2	SM3/16 (28) × 12
H42	H3205G1032	Feed rock shaft crank(left)	1	
H43	H3204G0031	Oil wick	1	

H.LOWER SHAFT & FEED ROCK SHAFT MECHANISM

Fig. No.	Part No.	Description	Pcs.	Remarks
H44	H3200G2030	Holder	1	
H45	H3200H2040	Bolt	1	
H46	H2013J0065	Washer	1	
H47	H3205H0651	Feed bar connecting fork	1	
H48	H3205H0652	Felt	1	
H49	H3205H0653	Screw	1	SM1/8 (44) × 4

I.HOOK SADDLE MECHANISM

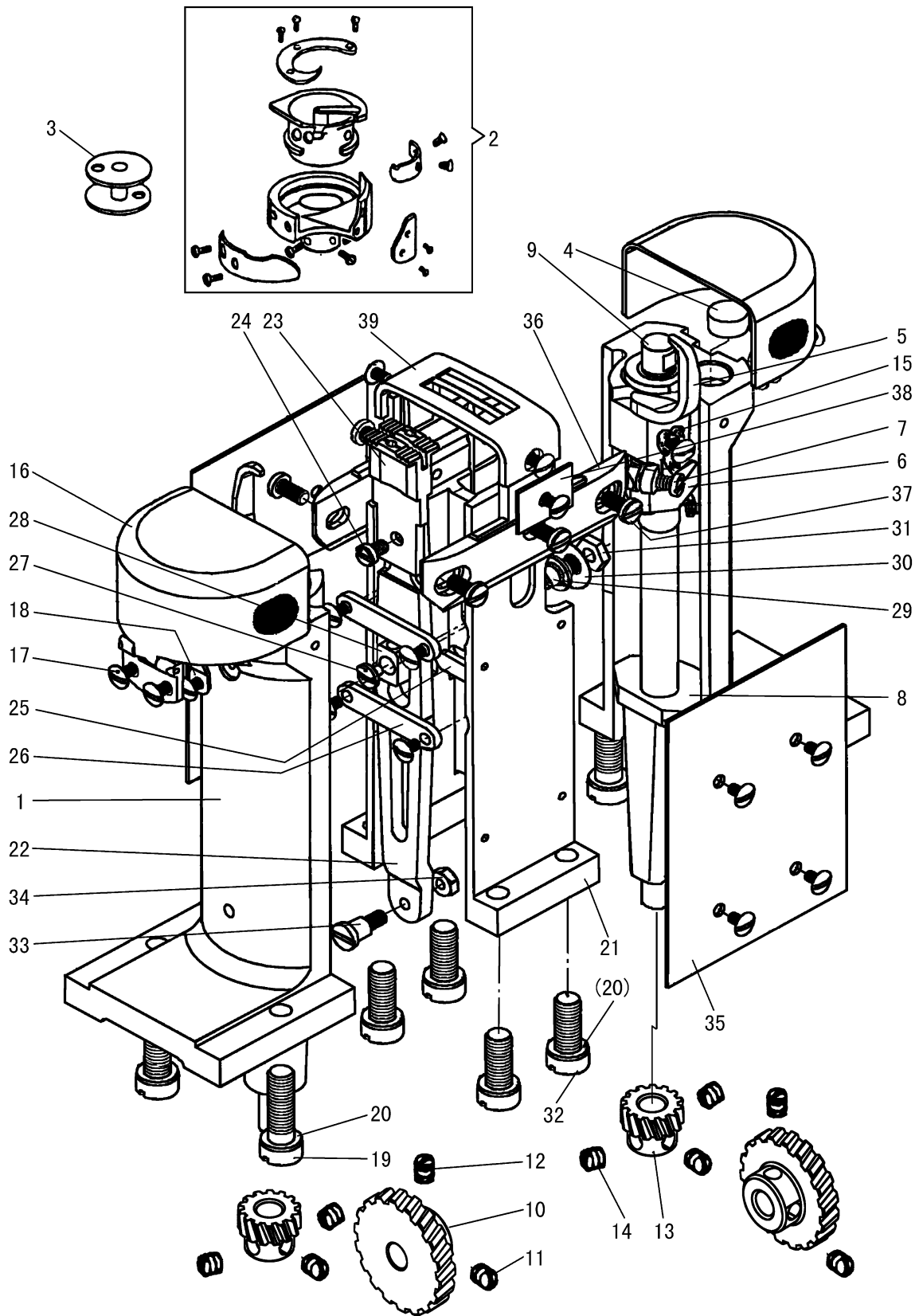

I.HOOK SADDLE MECHANISM

Fig. No.	Part No.	Description	Pcs.	Remarks
I01	HE504J8001	Hook saddle	2	
I02	HE507J7101	Hook	2	KRT8-LPK
I03	H3306I0067	Bobbin	2	
I04	HE511J8001	Felt	2	
I05	HE512J8001	Opener	2	
I06	HE513J8001	Crank	2	
I07	HE022K8001	Screw	2	SM11/64 (32) × 9
I08	HE514J8001	Felt	2	
I09	HE515J8001	Hook shaft	2	
I10	H32142I104	Gear(large)	2	
I11	HA307C0662	Set screw	2	SM1/4 (40) × 6
I12	H3204I6510	Set screw	2	SM1/4(40) × 6.5
I13	H32142I204	Gear (small)	2	
I14	HA105D0662	Set screw	6	SM1/4 (40) × 4
I15	HE516J8001	Oil wick	2	
I16	HE518J7101	Slide plate	2	
I17	HE517J8001	Screw	24	SM9/64 (40) × 5.5
I18	HE524J8001	Spring plate	2	
I19	HE525J8001	Screw	4	SM5/16 (20) × 26
I20	H005001080	Washer	8	GB/T97.1 8
I21	HE528J8001	Feed bar set bracket	1	
I22	HE530J8001	Feed bar	1	
I23	H0208I8001	Feed dog	1	3/16
I24	HE012E8001	Screw	1	SM11/64 (32) × 6.5
I25	HE532J8001	Felt	2	
I26	HE533J8001	Support plate	2	
I27	HE123I8001	Screw	1	SM1/8 (44) × 4
I28	HE535J8001	Square block	1	
I29	HE536J8001	Screw	1	SM7/32 (32) × 4.5
I30	HE045D8001	Washer	1	
I31	HE021B8001	Nut	1	
I32	HE538J8001	Screw	4	SM5/16 (20) × 18
I33	H0204I8001	Screw	1	SM3/16 (32) × 7.5
I34	HE540J8001	Nut	1	
I35	HE541J8001	Cover plate	2	
I36	HE542J8001	Hook support bracket	2	
I37	HE543J8001	Screw	6	SM3/16 (32) × 9.5
I38	HE544J8001	Plate	2	5/16
I39	H0207I8001	Needle plate	1	3/16

J.OIL LUBRICATION MECHANISM

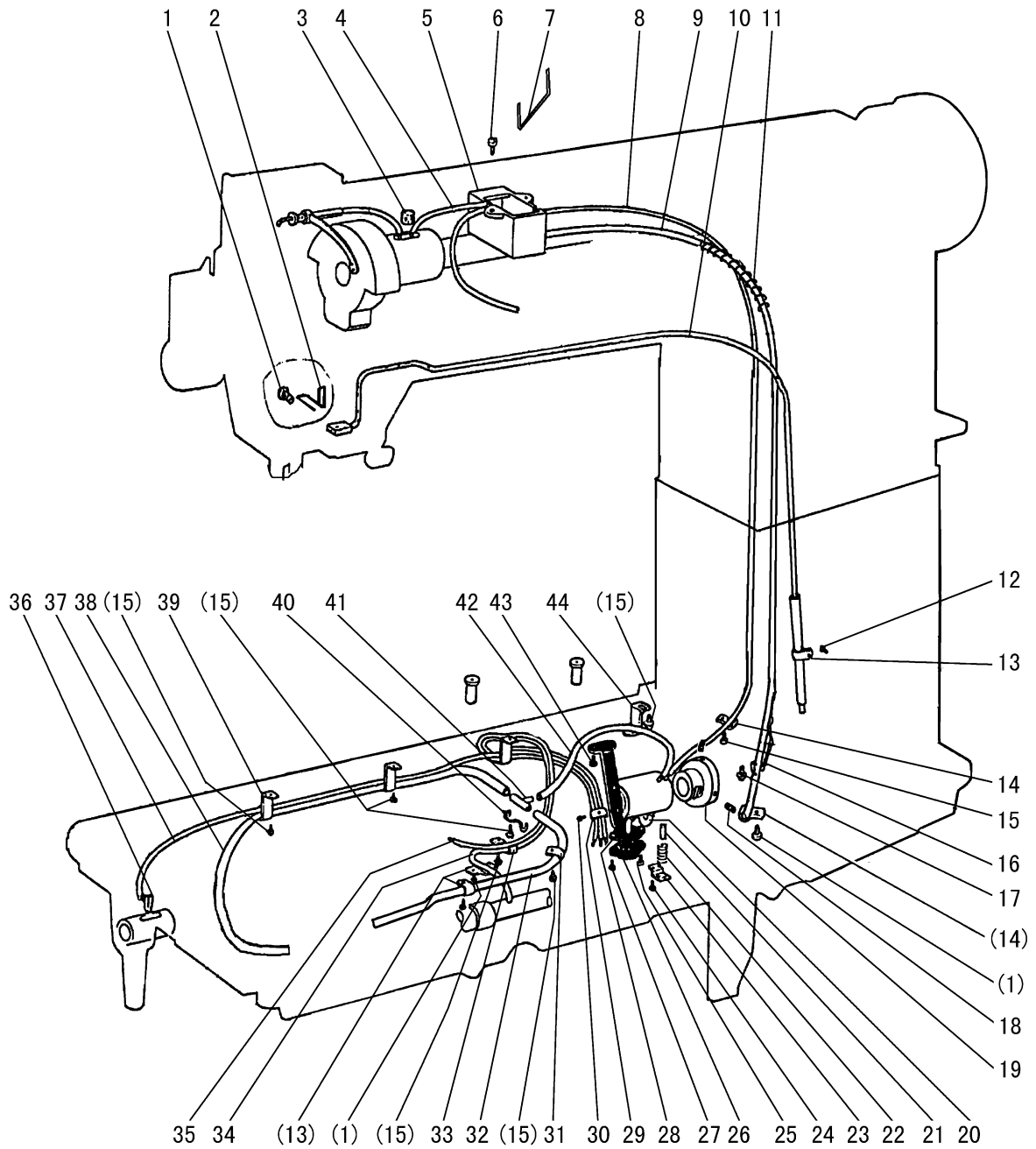

J.OIL LUBRICATION MECHANISM

Fig. No.	Part No.	Description	Pcs.	Remarks
J01	HA300C2030	Screw	3	SM11/64 (40) × 8
J02	H4731J8001	Holder	1	
J03	H32175B304	Felt	1	
J04	H4705J7101	Oil pipe & wick complete	1	
J05	H3204K0011	Oil tank complete	1	
J06	H411040160	Screw	2	GB/T819.1 M4×16
J07	H4707J8001	Holder	1	
J08	H0204K8001	Oil pipe	1	
J09	H0205K8001	Oil pipe	1	
J10	H0206K7101	Oil pipe complete	1	
J11	H4710J8001	Spring	2	
J12	HA7311CC06	Screw	7	SM9/64 (40) × 6.5
J13	H2000M0110	Holder	1	
J14	H3200K0190	Holder	2	
J15	HA300B2130	Screw	6	SM11/64 (40) × 5.5
J16	H3200K0200	Holder	1	
J17	HA300B2170	Screw	1	SM11/64 (40) × 9
J18	H3230K0751	Set screw	2	SM11/64 (40) × 10
J19	H3230K0752	Bushing	1	
J20	H3215K0696	Oil pipe	1	
J21	H1100I2070	Plunger	1	
J22	H1100I2090	Coil spring	1	
J23	H1100I2110	Guide plate	1	
J24	H3204D6510	Screw	1	SM1/8 (44) × 4.8
J25	H3215K0693	Screw	1	SM9/64 (40) × 5
J26	H3215K0692	Filter	1	
J27	H3215K0694	Screw	1	SM9/64 (40) × 7
J28	H3215K4011	Base plate complete	1	
J29	H3215K0695	Holder	1	
J30	HA106B0676	Screw	1	SM9/64 (40) × 6
J31	H32311D606	Holder	1	
J32	H3210K0672	Oil pipe	1	
J33	H3200K0170	Holder	1	
J34	H3218K0072	Oil pipe complete	1	
J35	H3217K0071	Oil pipe complete	1	
J36	H3200K0180	Oil wick	1	
J37	H3216K0070	Oil pipe complete	1	
J38	H3204K0655	Oil pipe	1	
J39	H3200K0160	Holder	3	
J40	H3210K0674	Holder	1	
J41	H3210K0671	Oil pipe connector	1	
J42	H3210K0673	Oil pipe	1	
J43	HA100E2150	Screw	1	SM11/64 (40) × 10
J44	H3200K0250	Holding plate	1	

K.ACCESSORIES

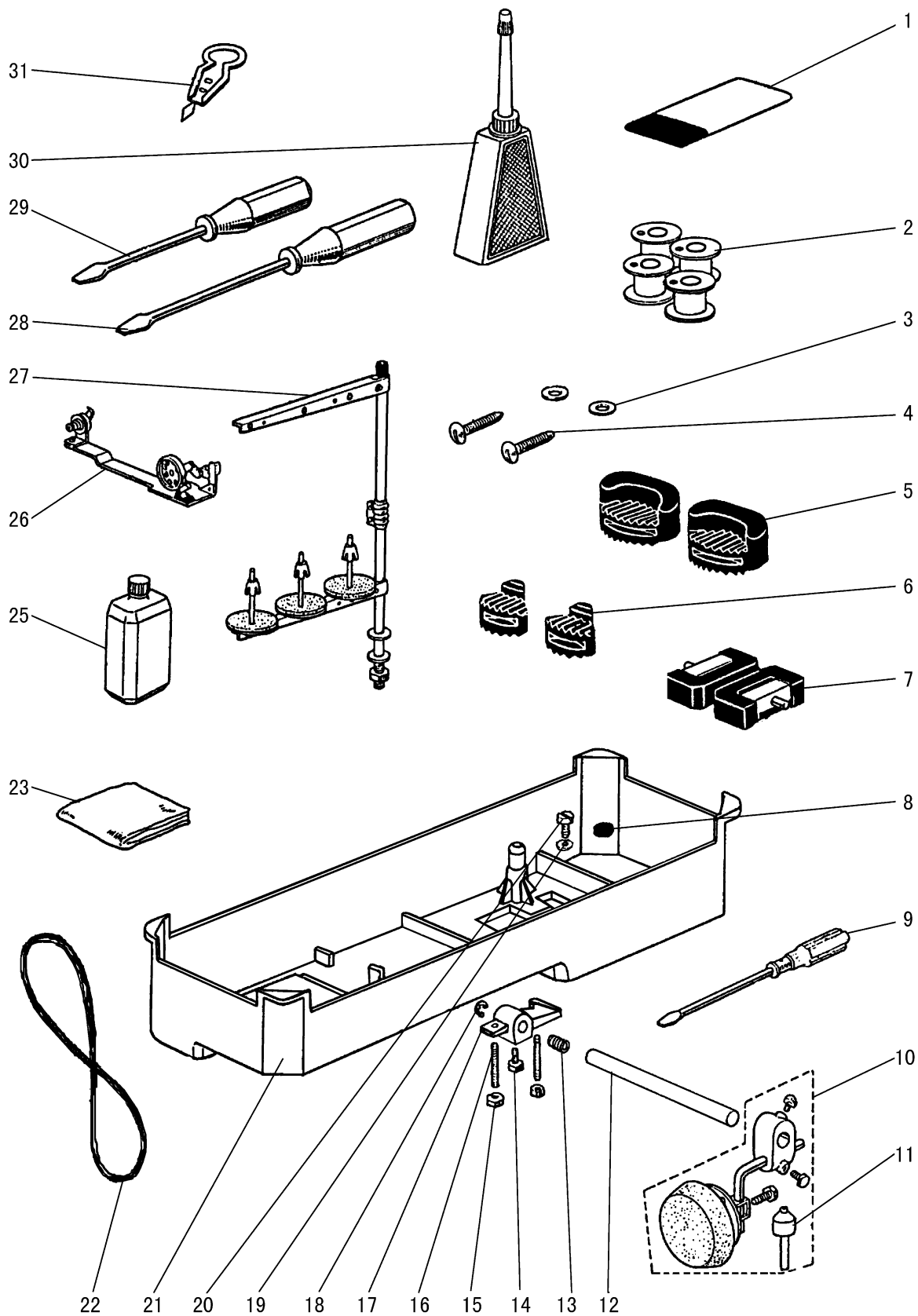

K.ACCESSORIES

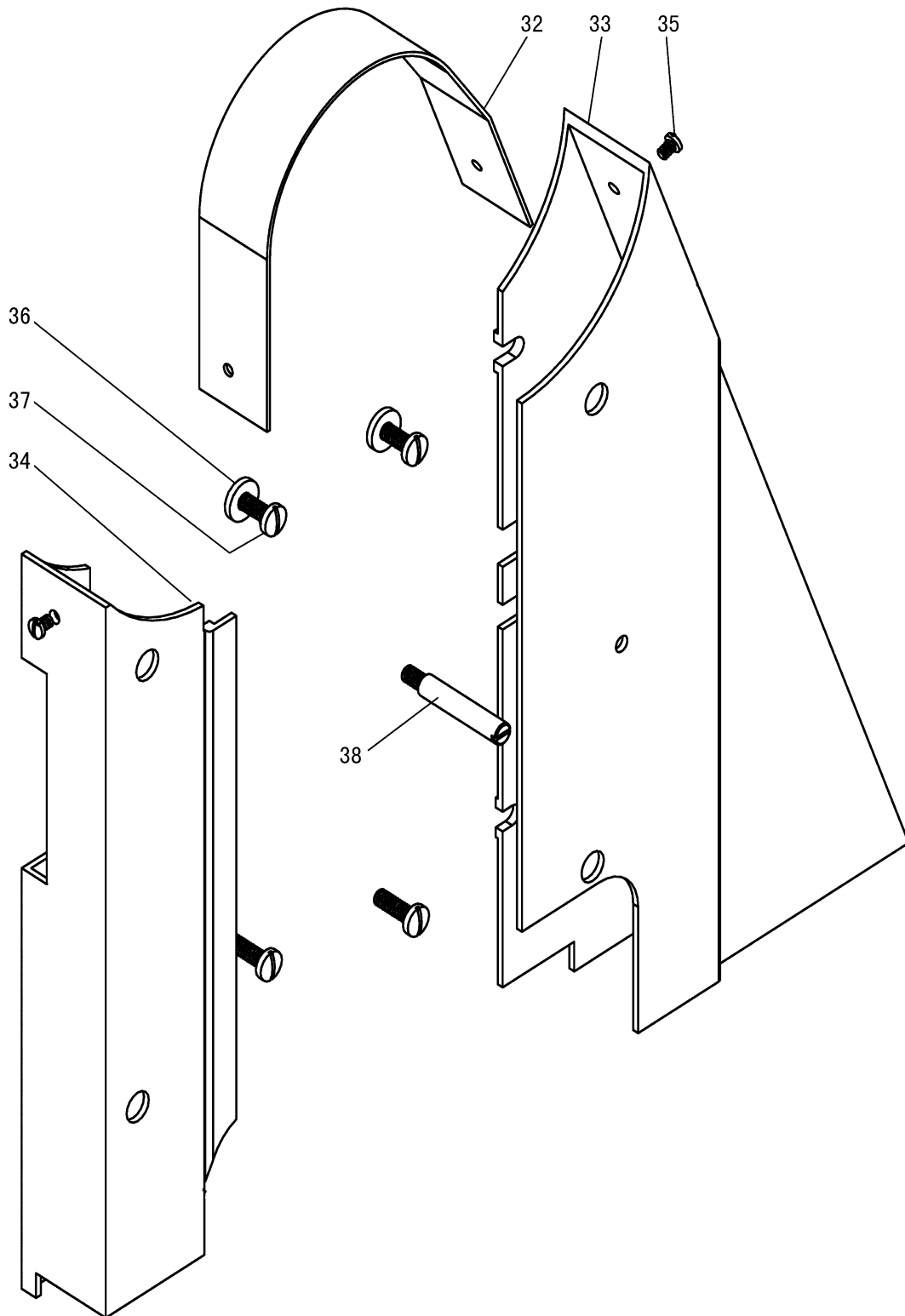

K.ACCESSORIES

Fig. No.	Part No.	Description	Pcs.	Remarks
K01	JZDP1700G2102	Needle	1	DP×17 21#
K02	H3306I0067	Bobbin	4	
K03	HA300J2230	Washer	4	
K04	H801045200	Wood screw	4	
K05	H3200L0020	Vibration preventing rubber	2	
K06	H3200L0030	Vibration preventing rubber	2	
K07	HA307J0067	Hinge complete	2	
K08	HA100J2120	Magnet	1	
K09	HA300J2070	Screw driver (larger)	1	
K10	H3214L0067	Small parts	1	
K11	H3214L2011	Knee lifter pin	1	
K12	H3213L0662	Knee lifter shaft	1	
K13	HA104J0657	Spring	1	
K14	HA104J0659	Screw	2	SM15/64 (28) ×28
K15	HA104J6510	Nut	2	
K16	HA106J0664	Screw	1	SM15/64 (18) ×13
K17	H3213L0664	Knee lifter crank	1	
K18	H007013090	E-type ring	1	GB/T 896 9
K19	HA104J0653	Washer	1	
K20	HA104J0652	Screw	1	SM5/16 (28) ×10
K21	H3213L0661	Oil reservoir	1	
K22	H2400K0080	M-type belt	1	
K23	HA100J2180	Vinyl cover	1	
K25	H3200L0130	Oil tank	1	
K26	HA706S0067	Bobbin winder complete	1	
K27	H3200L0120	Cotton stand	1	
K28	HA300J2200	Screw driver(middle)	1	
K29	HA300J2210	Screw driver (small)	1	
K30	HA100J2110	Oiler	1	
K31	H3207L0065	Thread a needle kit	1	
K32	H6307L8001	Belt cover (upper)	1	
K33	H6309L8001	Belt cover (right)	1	
K34	H6310L8001	Belt cover (left)	1	
K35	H200000360	Screw	2	SM11/64 (40) ×6.2
K36	H6722N8001	Washer	2	
K37	H0207L8001	Screw	4	SM15/64 (28) ×18
K38	H0208L8001	Screw	1	SM15/64 (28) ×10

GAUGE PARTS LIST

Description Width	Presser Foot	Needle Clamp	Needle Plate	Plate	Feed Dog	Hook Support Bracket
1/2" (12.7)	H3309E0070	H3400C2120	HD808I8001	HD809I8001	HD807I8001	HD810I8001
3/8" (9.5)	H3308E0069	H3400C2110	HD813I8001	HE307I8001	HE306I8001	HE542J8001
5/16" (8)	H3306E0067	H3400C2100	HD812I8001	HE544J8001	HE531J8001	HE542J8001
1/4" (6.4)	H3304E0065	H3410C3013	H0210I8001	H0212I8001	H0211I8001	HE542J8001
3/16" (4.8)	H3305E0066	H3400C2090	H0207I8001	H0209I8001	H0208I8001	HE542J8001
Quantity	1	2	1	2	1	2

SHANGHAI HUIGONG NO.3 SEWING MACHINE FACTORY

ADD: 1418, Yishan Road, Shanghai, China

Zip Code: 201103

Overseas Business: TEL: 86-21-64853303 FAX: 86-21-64854304

E-mail: highlead@online.sh.cn <http://www.highlead.com.cn>

The description covered in this manual is subject to change for improvement of the commodity without notice

2009.6. Printed