



**HIGHLEAD**

**GC24018/GC24018-1**

**Post bed Single(Double) Needle Lockstitch  
Sewing Machine**

**Instruction Manual  
Parts Catalog**

---

--- CONTENT ---

1. Safety Precautions.....	2
2. Precautions before Starting Operation.....	2
3. Precautions for Operating Conditions.....	2
4. Place of Installation of Machine.....	2
5. How to Mount The Machine Head onto The Table.....	2
6. Mounting of The Motor.....	3
7. How to Connect The Motor Lever and Foot Pedal.....	3
8. How to Mount The Bobbin Winder Assembly.....	3
9. How to Mount and Adjust The Knee Lifter Mechanism.....	3
10. How to Mount The Oil Pan.....	4
11. How to Mount The Vibration Preventing Rubber.....	4
12. Selection of Thread.....	5
13. How to Attach The Needle.....	5
14. How to Lead The Upper Thread.....	6
15. How to Wind the Lower Thread on The Bobbin.....	7
16. How to Adjust The Bobbin Winder Assembly.....	7
17. How to Place the Bobbin into The Hook.....	8
18. Starting to Sewing.....	9
19. Sewing Over.....	10
20. Adjustment of Stitch Length.....	10
21. Reverse stitching.....	10
22. Adjustment of Thread Tension.....	10
23. Tension of Upper Thread.....	11
24. Tension of Lower Thread.....	12
25. Adjustment of Feed Dog Height and Pressure of Presser on Materials.....	13
26. Proper Timing Between Hook and Needle.....	14
27. Proper Timing Between Hook and Opener.....	17
28. Proper Timing between Feed Dog and Needle.....	18
29. Cleaning and Lubrication.....	19
A. ARM BED AND ITS ACCESSORIES.....	20
B. THREAD TENSION REGULATOR MECHANISM.....	22
C. NEEDLE BAR AND TAKE-UP LEVER MECHANISM.....	24
D. UPPER SHAFT AND VERTICAL SHAFT MECHANISM.....	26
E. STICH REGULATOR MECHANISM.....	29
F. PRESSER FOOT AND KNEE LIFTER MECHANISM.....	31
G. LOWER SHAFT AND FEED ROCK SHAFT MECHANISM.....	34
H. HOOK SADDLE MECHANISM.....	37
I. OIL LUBRICATION MECHANISM.....	40
J. ACCESSORIES .....	42

---

## 1. Safety Precautions:

- (1) When turning the power on, keep your hands and fingers away from the area around/under the needle and the area around the balance wheel.
- (2) Power must be turned off when the machine is not in use, or when the operator leaves the seat.
- (3) Power must be turned off when tilting the machine head, installing or removing the "V" belt, adjusting the machine, or when replacing.
- (4) Avoid placing fingers, hairs, bars etc., near the balance wheel, "V" belt, bobbin winder balance wheel, or motor when the machine is in operation.
- (5) Do not insert fingers into the thread take-up cover, under/around the needle, or balance wheel when the machine is in operation.
- (6) If a belt cover, finger guard, eye guard are installed, do not operate the machine without these safety devices.

## 2. Precautions before Starting Operation:

- (1) If the machine's oil pan has an oil sump, never operate the machine before filling it.
- (2) If the machine is lubricated by a drop oiler, never operate the machine before lubricating.
- (3) When a new sewing machine is first turned on, verify the rotational direction of the balance wheel with the power on. (The balance wheel should rotate counter-clockwise when viewed from the balance wheel)
- (4) Verify the voltage and (single or three) phase with those given on the machine nameplate.

## 3. Precautions for Operating Conditions:

- (1) Avoid using the machine at abnormally high temperature (35°C or higher) or low temperature (5°C or lower) .
- (2) Avoid using the machine in dusty conditions.

## 4. Place of Installation of Machine

The machine should be installed on well-leveled floor in order to ensure smooth operating of your machine at high speed without vibration.

## 5. How to Mount The Machine Head onto The Table (Fig.1)

Install the hinge with screws, provided in accessory, at hole on the back of the bed and hook to the hinge plate of the table, then the head is set on the table.

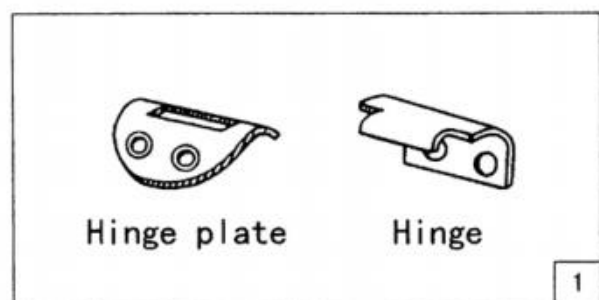

## 6. Mounting of The Motor (Fig.2)

The motor is mounted generally with bolts, nuts, and washers as provided. Set the position so that the motor pulley and the balance wheel grooves are aligned straight as shown in Fig. 2. For proper operation when the belt is inserted. Then connect power supply cord and motor cord extended from switch.

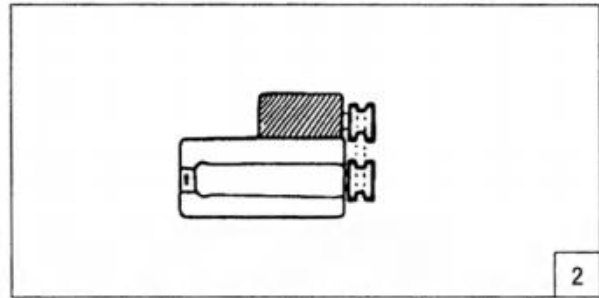

## 7. How to Connect The Motor Lever and Foot Pedal (Fig.3)

The angle of the slope of the pedal can be important. It can make a difference in the strength necessary to press the pedal. There might be a slight difference in operator's posture, but generally  $30^{\circ} \sim 40^{\circ}$  angle as shown in Fig.3 (1) is considered best. The treadle position shown in Fig.3 (2) will be difficult. In this case, adjust the length of the connecting rod to suit the operator.

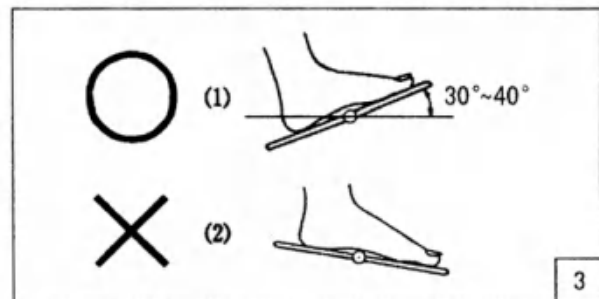

## 8. How to Mount The Bobbin Winder

### Assembly (Fig.4)

Set the position of the bobbin winder assembly provided in accessory, to be in parallel with the belt hole of the table, with the lever pushed in operation position. When bobbin winder pulley will come in contact with the belt, fix the assembly onto the table with two screws provided.

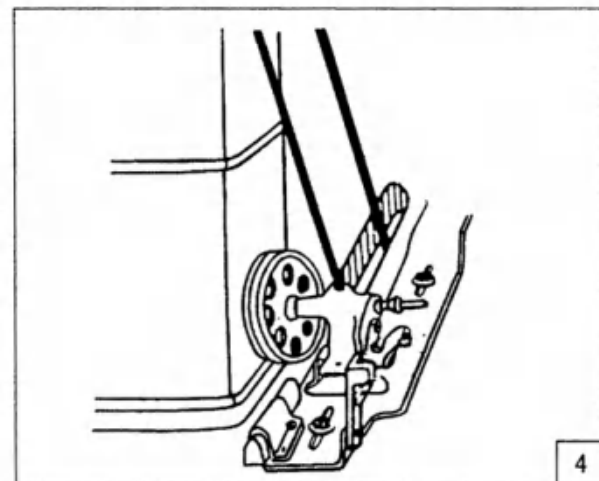

## 9. How to Mount and Adjust The Knee

### Lifter Mechanism

#### (1) Place of mounting (Fig.5)

Make a hole for knee lifter shaft bracket underneath the table according to Fig.5 shown.

#### (2) How to Mount (Fig.6)

- 1) Mount the knee lifter shaft bracket 1 while the side of hole for spring towards your side.
- 2) The other side of the knee lifter shaft bracket is screwed so as able to insert the knee lifter shaft.
- 3) On the knee lifter shaft, mount the knee lifter position bracket 3, regulating rod bracket 9, knee

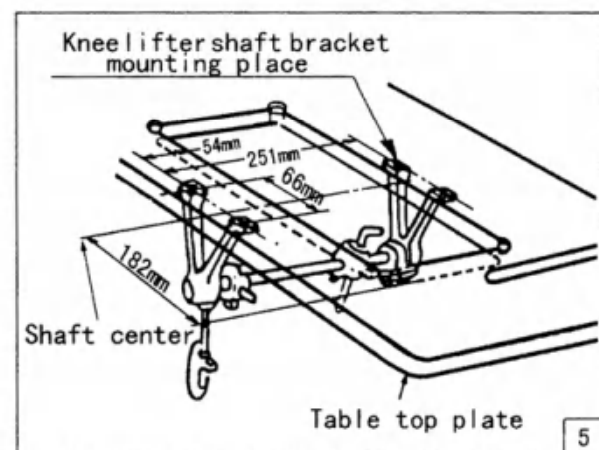
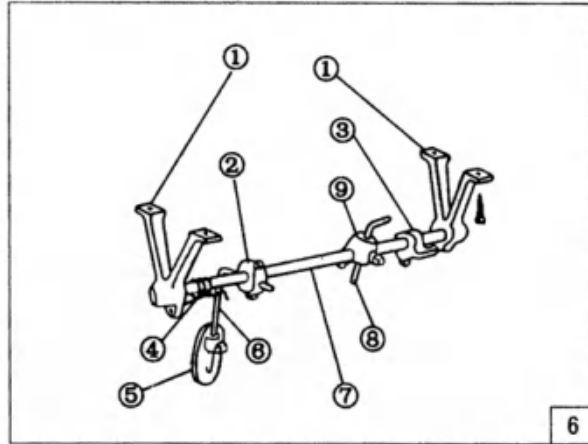

plate bar bracket 2, and spring 4 in the order mentioned, and then tighten respectively.

- 4) Mount the knee lifter shaft 7, on which fixed respective parts, on the shaft bracket 1.
- 5) After checking up all the parts and inclination of the knee lifter shaft, tighten the shaft bracket screws.
- 6) The shorter side of knee plate bar 6 is mounted on the bar bracket 2, and longer side of the bar is mounted on the knee plate 5.
- 7) The end of spring is inserted into a hole of the shaft bracket (front) 1.
- 8) The other end of spring is placed on the knee plate bar moving it.
- 9) After mounting all these parts, check whether the knee lifter mechanism can be operated lightly.



(3) Adjustment (Fig.7)

- 1) Place of knee lifter position bracket. Since the position bracket makes standardize the starting point of knee plate, tighten the screw at the proper position so that the stopper of position bracket come contact with top underneath of the shaft bracket (back).
- 2) Position of the knee lifter bell crank regulating rod and its bracket. The regulating rod 3 makes raise and down the presser foot by means of moving the bell crank lever 1 up and down. While the presser foot downed adjust the length A loosening the regulating rod screw so that the rod and crank lever contacts with as shown in Fig.7.

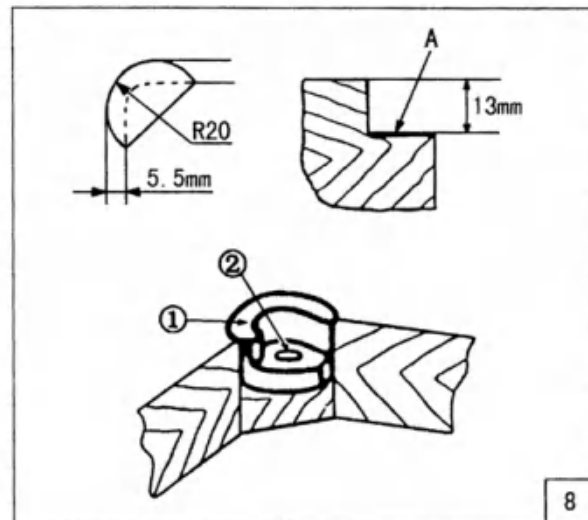
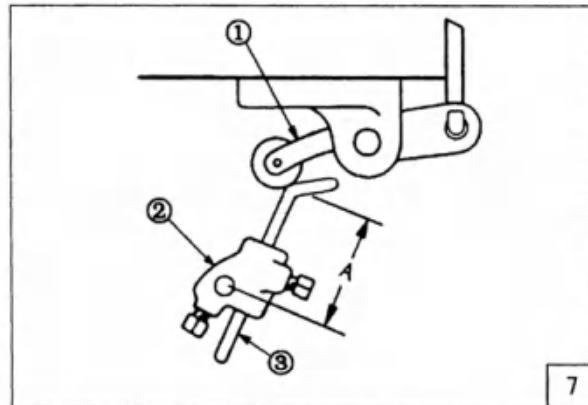

### 10. How to Mount The Oil Pan

Fit the oil pan with nails into the hole bored in the table so as not to come into contact with the knee lifter mechanism.

### 11. How to Mount The Vibration Preventing Rubber (Fig.8)

The vibration preventing rubber 1 is used to prevent the machine from vibrating and there by provide smooth operation of the machine. Fit these rubber insulators properly at the four corners of the table as shown in Fig.8. Remember, the machine will vibrate if these are not mounted properly.

- (1) Hollow out four corners of the table 20 mm radius and 13 mm depth to fit the rubber insulators. Be sure to give smooth surface to "A" where hollow out is made.
- (2) Nail the vibration preventing rubbers down at the four corners.

## 12. Selection of Thread (Fig.9)

For best results, use high quality machine thread. For upper thread use left-twist thread. To check whether a thread is left-twist or right-twist, hold the thread as shown in Fig.9, and twist the thread held in the right hand toward your side. If the thread twist becomes loose, the thread is right-twist, and if the thread twist becomes tight the thread is left-twist.

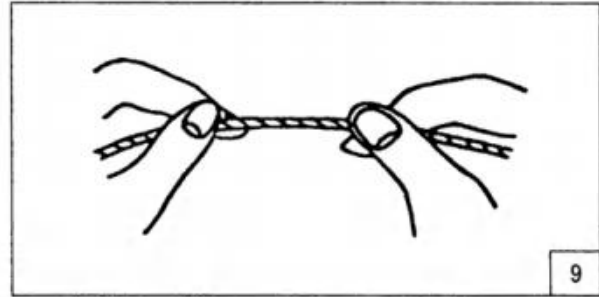

## 13. How to Attach The Needle

(1) For one needle type (Fig.10)

- 1) While the presser bar lifter is raised, turn the balance wheel by hand to raise the needle bar to its highest position.
- 2) Move the roller foot 1 to the left as shown in Fig.10.
- 3) Loosen the needle clamping screw 2.
- 4) Hold the needle to its side with the long groove side (left). Then insert the needle as deeply as it will go into the needle clamping hole.
- 5) Securely tighten the needle clamping screw 2.

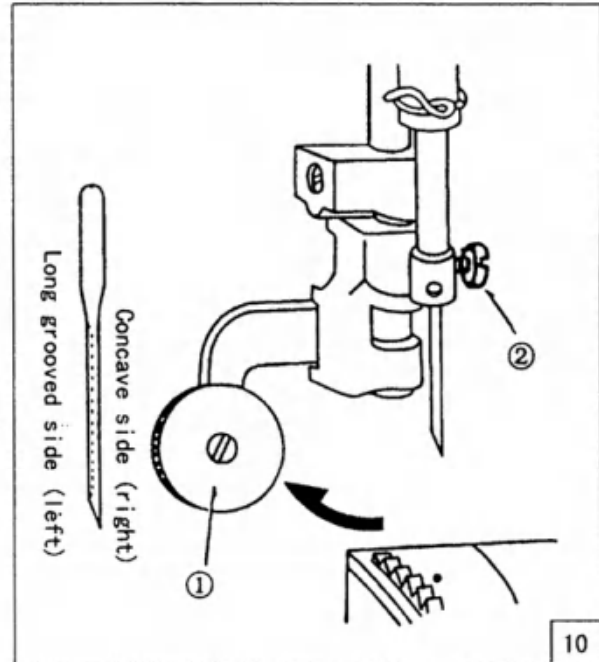

(2) For two needle type (Fig.11)

- 1) While the presser bar lifter is raised, turn the balance wheel by hand to raise the needle bar to its highest position.
- 2) Move the roller foot to the left as shown in Fig.11.
- 3) Loosen the needle clamping screw.
- 4) Hold the needles so that the two needles side with the long grooved (face to face), and insert it as deeply as it will go into the needle clamping hole.
- 5) Securely tighten the needle clamping screw.

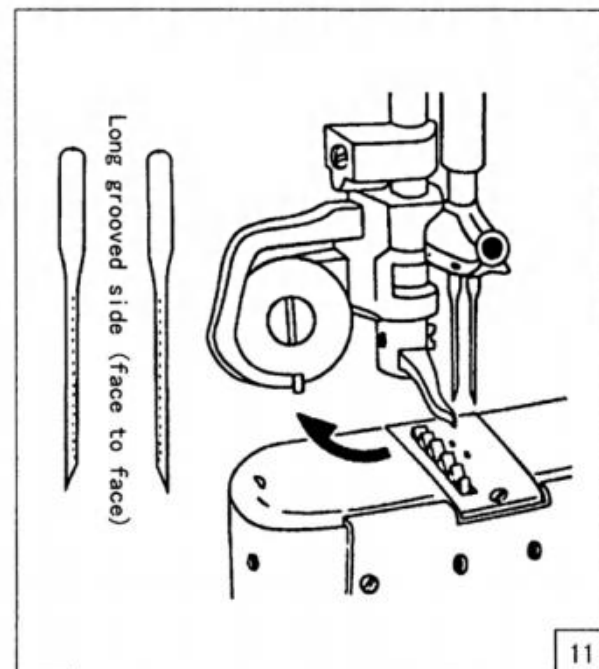

Caution: When using nylon or silk threads, the loops may be formed improperly or stitch skipping

may result due to the twist of these threads. In this case, observe the condition of the loops and mount the needle in a manner that the needle hole would be positioned in a slightly oblique direction. (Fig. 12)

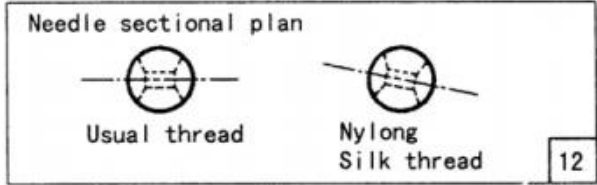

### 14. How to Lead The Upper Thread

(1) For one needle type (Fig. 13)

- 1) Raise the thread take-up lever to its highest position turning the balance wheel by hand.
- 2) After the presser bar lifter is raised, move the roller foot to the left holding downward as per arrow shown in Fig. 13.
- 3) Thread in the order from ① to ⑨, and then pass the needle from the left to the right. (Fig. 14)

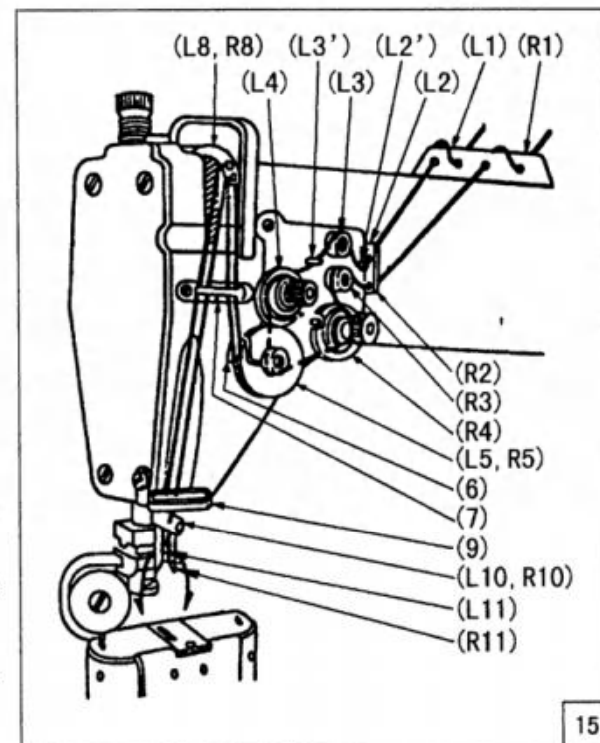
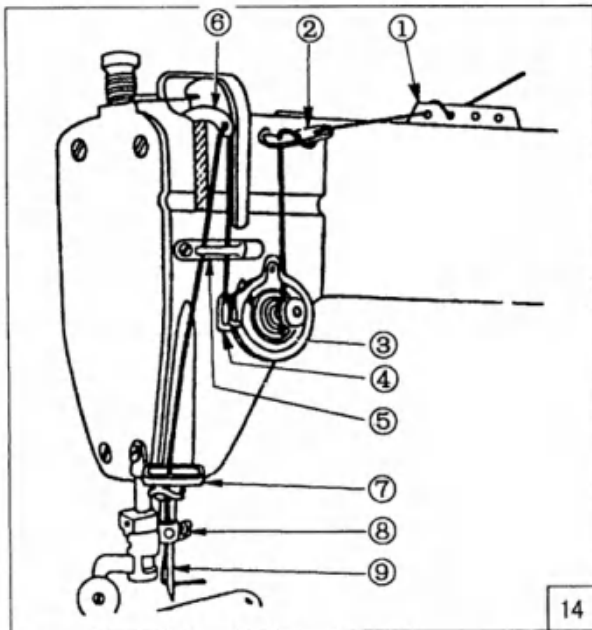
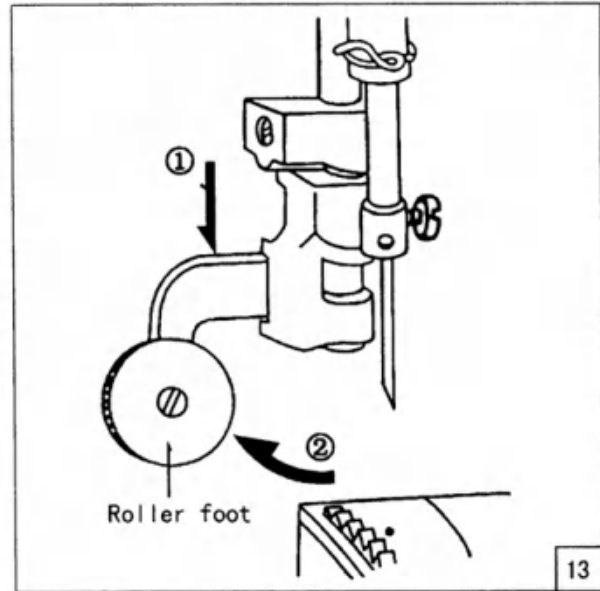

(2) For two needle type (Fig. 15)

- 1) Raise the thread take-up lever to its highest position turning the balance wheel by hand.
- 2) In case of the roller foot, it is same order as one needle type did-move the roller foot to the left.
- 3) Thread in the following order (left): L1, L2, L2', L3, L3', L4, L5, 6, 7, L8, 7, 9, L10, L11.
- 4) Thread in the following order (right): R1, R2, R3, R4, R5, 6, 7, R8, 7, 9, R10, R11.
- 5) Thread from the inside to outside.

## 15. How to Wind the Lower Thread on The Bobbin (Fig.16)

(1) Thread from the spool through the hole of the thread guide 2 to the tension discs 1.

(2) Wind the end of the thread through the tension discs 1 on the bobbin 3 about 5-6 times.

(3) Fit the bobbin into the bobbin pin 4 in a manner so the thread can be wound on the bobbin from the underside.

(4) Push the lever 5 toward the other side so that the pulley at the belt will engage.

(5) Operate the machine so that the thread can be wound on the bobbin.

(6) The bobbin winder will automatically be free from the belt when the bobbin is fully wound with thread, and stopped.

(7) This operation can be done while working.

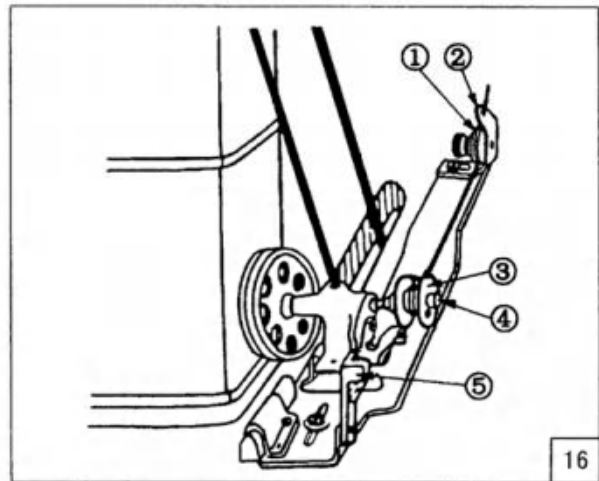

## 16. How to Adjust The Bobbin Winder Assembly (Fig.17, 18)

It is desirable that the bobbin is wound evenly with thread as shown in Fig.17 (A), but Fig.17 (B) and (C) shown are not proper winding. Adjust the bobbin winder assembly in the following order so as able to wind the thread onto the bobbin properly.

(1) In case of uneven winding. In the event of uneven winding toward the left, loosen the screw 1, of the thread guide, and adjust it moving the thread guide slightly to the right. In the event of uneven winding toward the right, adjust it moving the guide to the left. After adjusting, tighten the screw 1 of the thread guide.

(2) Winding strength of thread. When the thread (particularly nylon thread) is wound too tightly, there is a tendency to unwind the thread on a bobbin. In this case adjust the pressure of tension discs with nut 2 so that thread can be pulled out smoothly.

(3) Winding amount of thread. Best results are obtained when the bobbin is wound up to 4/5 of its full capacity with thread. Excessive winding will results in poor pull out the thread. In the event of excessive winding, turn the screw 3 to the left, and to the right when insufficient.

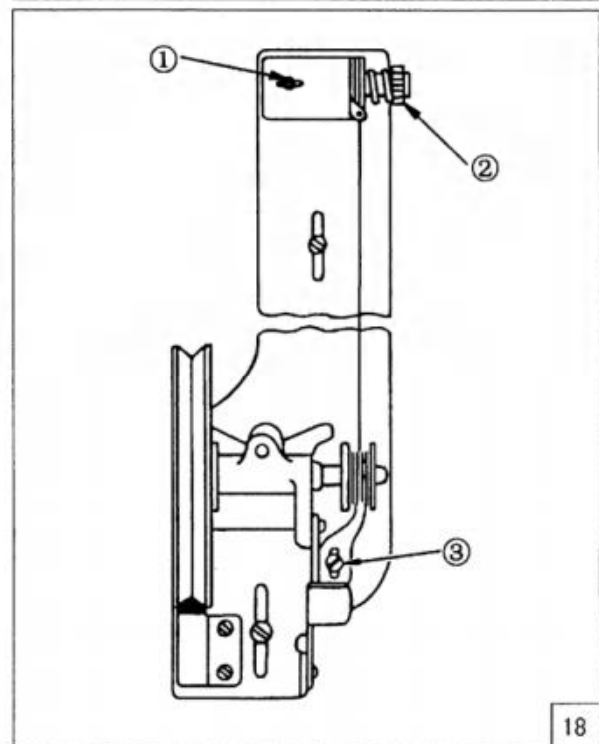
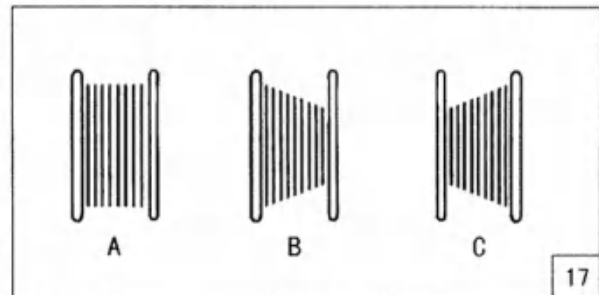



## 17. How to Place the Bobbin into The Hook

(1) For one needle type (Fig.19, 20, 21)

- 1) Raise the needle bar to its highest position turning the balance wheel by hand.
- 2) Move the roller foot 1 to the left as shown in Fig.19.
- 3) Move the slide plate.
- 4) Turn up the latch lever 2 as shown in Fig.19.
- 5) Pull the bobbin thread for about 5 cm; hold it like in the illustration.
- 6) Fit the bobbin, into the hook base 3.
- 7) Flap down the latch lever 2.
- 8) Insert the pulled out thread end through the slit 5 in the hook body.
- 9) From the slit 5 pass the thread underneath the hook body 4, and pull it to the right diagonally, and the thread will pass through tension spring 6.
- 10) Leave the end of thread inserted through to the tension spring 6 as it is.
- 11) While holding the end of upper thread by left hand, turn the balande wheel slowly once around by right hand.
- 12) Then the upper thread will hook out the lower thread simultaneously through the hole of needle plate, and leave the lower thread to other side of the needle plate.
- 13) After placing the bobbin, close the slide plate.

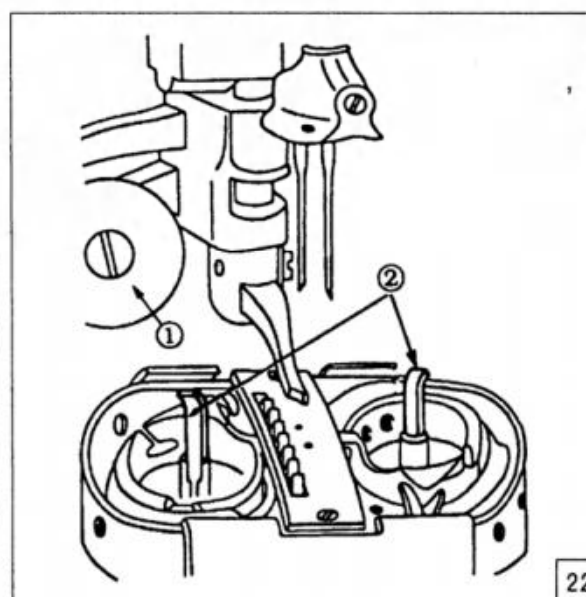
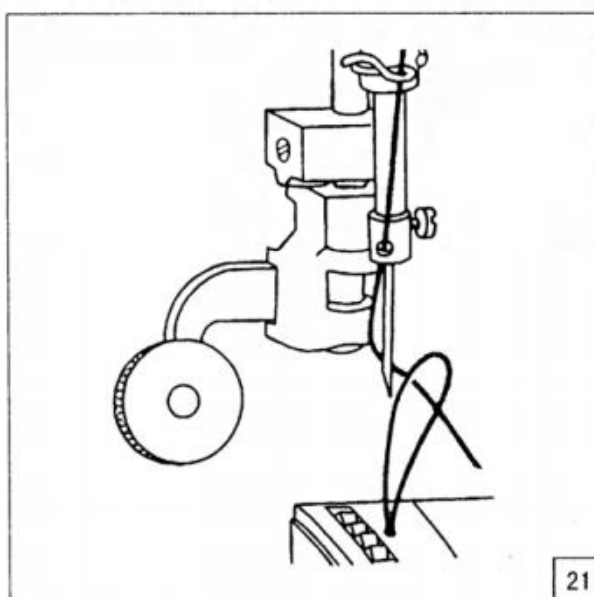
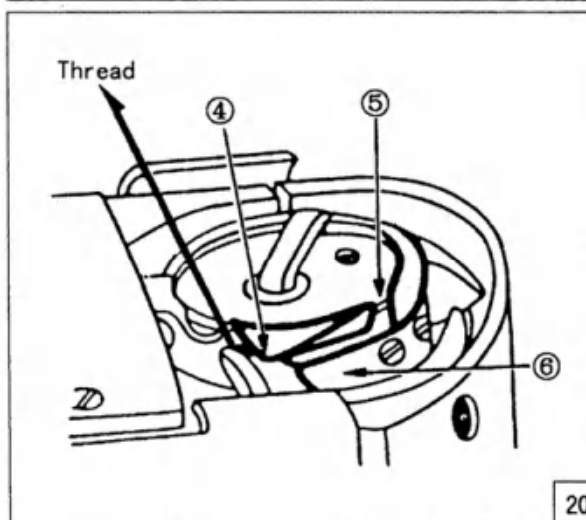
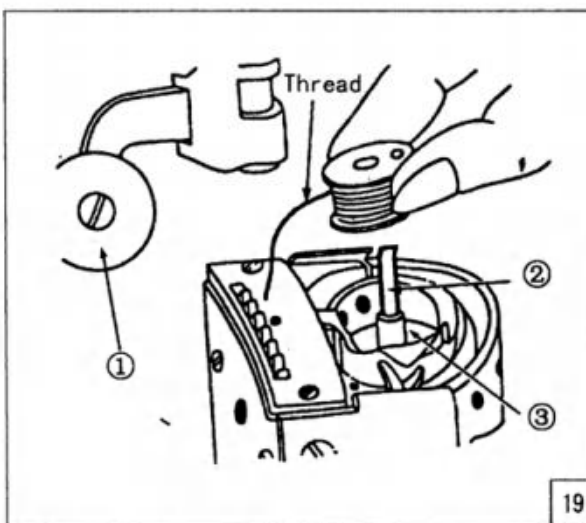

(2) For two needle type (Fig.22, 23, 24)

- 1) Raise the needle bar to its highest position turning the balance wheel by hand.
- 2) In the event of the roller foot 1 is attached, move it to the left as shown in Fig.22.
- 3) Move the both slide plate.
- 4) Turn up the both of the latch lever 2 as shown in Fig.22
- 5) Pull out the bobbin thread for about 5 cm, and hold the bobbin.
- 6) Fit the bobbin into the both hook base.
- 7) Flap down the both latch lever 2 as it was.
- 8) Insert the pulled thread end through slit 5 of the hook.
- 9) From the slit 5 of the hook, pass the thread through underneath of the hook body 4, pull the left thread to the left and the right thread to the right diagonally and the thread will pass through the tension spring 6 as shown in Fig.23.
- 10) Leave the end of the thread inserted through the tension spring 6 as it is.
- 11) While holding the end of two upper thread by left hand, turn the balance wheel slowly once around by right hand.
- 12) Then the two upper thread will hook out pulling the lower thread simultaneously through the hole of needle plate, and leave the lower thread to the other side of the needle plate as shown Fig.24
- 13) After placing the bobbin, close the both of the slide plate.

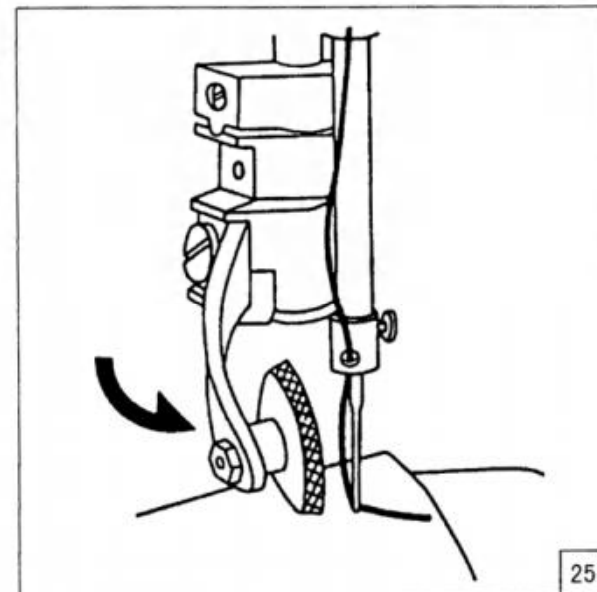
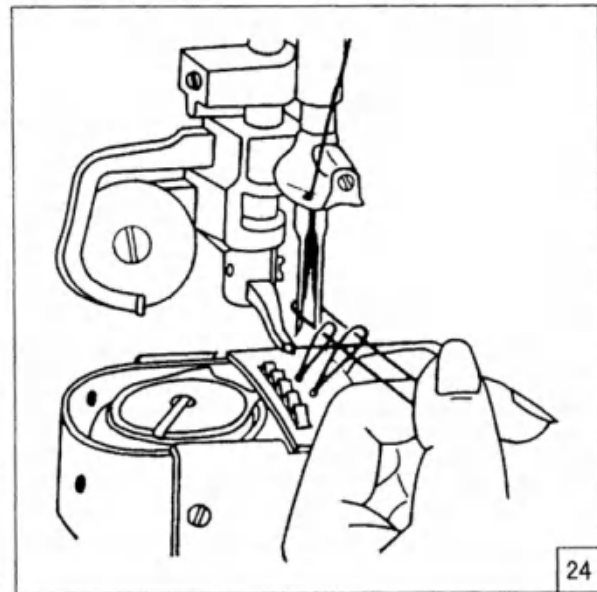
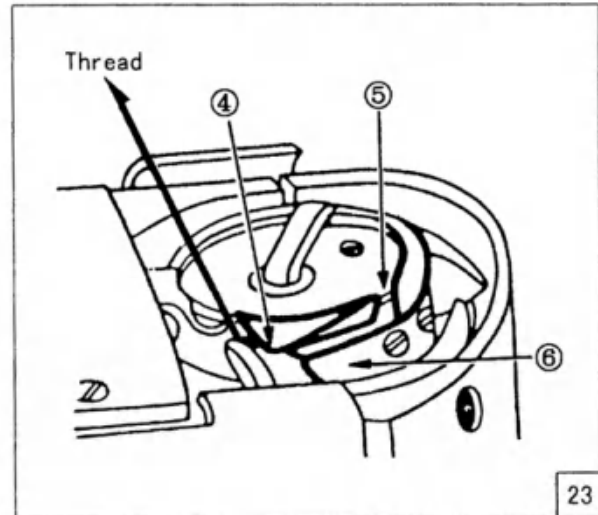

### 18. Starting to Sewing (Fig.25)

- (1) Raise the presser bar lifter.
- (2) Move back the roller foot toward your side as shown in Fig.25 by the arrow.
- (3) Place starting end of the materials for stitching under the needles.
- (4) Turn the balance wheel by hand toward your side so that the needle stitches the materials.
- (5) Lower the presser bar lifter and start to sew.

Caution: When starting to sewing, leave the upper thread pulled out by approx. 10 cm in length so that it will not pull out from needle.

## 19. Sewing Over (Fig.26)

(1) Stop sewing when the take-up lever comes to its highest position.

(2) Raise the presser (roller or ordinary) foot.

(3) Pull out the stitched fabrics diagonally to the left side.

(4) Cut both upper and lower thread.

Caution: When cutting the thread leave out approx. 10 cm length so that next starting sew is convenient for you.

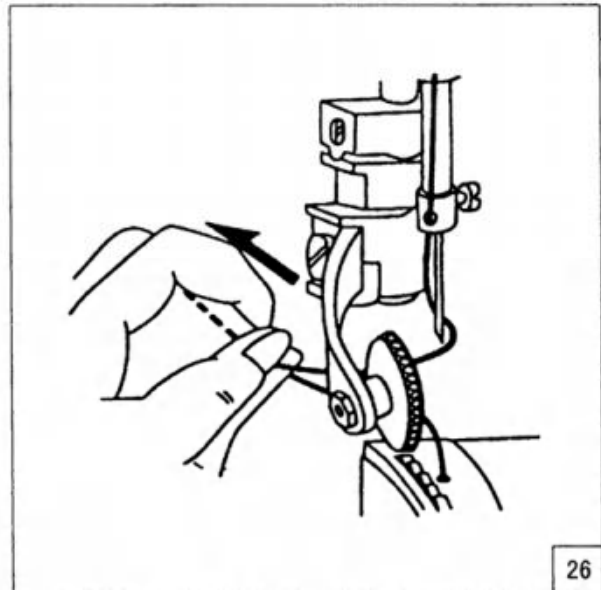

## 20. Adjustment of Stitch Length (Fig.27)

Stitch length can be adjusted with lever pushed and the stitch-regulating dial 3. Figures on the stitch-regulating dial 3 indicate the length in mm. When the dial number is set on the pin of the arm, it will give your desired stitch length.

## 21. Reverse stitching (Fig.27)

Reverse stitching can be operated by means of pushing the reverse lever 4 downward. While the lever 4 is pressed downward, reverse stitching can be made.

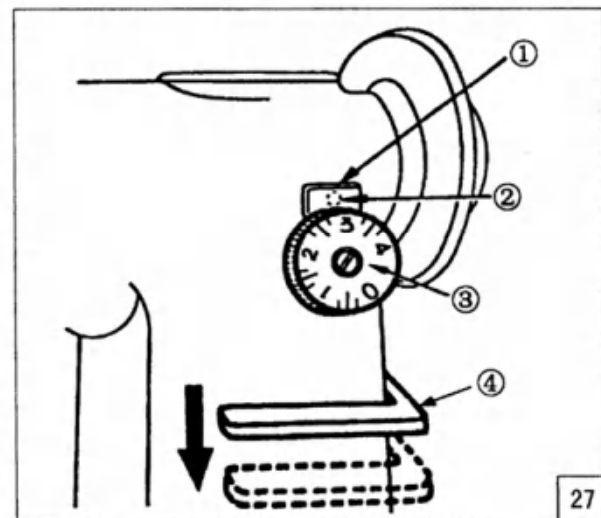

## 22. Adjustment of Thread Tension (Fig.28)

The thread tension varies according to the type of materials to be sewn, thread and the stitch length. So adjust the tension accordingly. If the upper and lower thread tension are well balanced, the two threads will link together in the middle of the fabrics to provide perfect chain like stitches A as shown in Fig. 28. If, either the upper or lower thread tension is too tight, or too loose, it will give imperfect stitches such as B and C as shown in Fig. 28. Fig. 28 B shows the upper thread tension is too tight, and Fig. 28 C shows the upper thread tension is too loose.

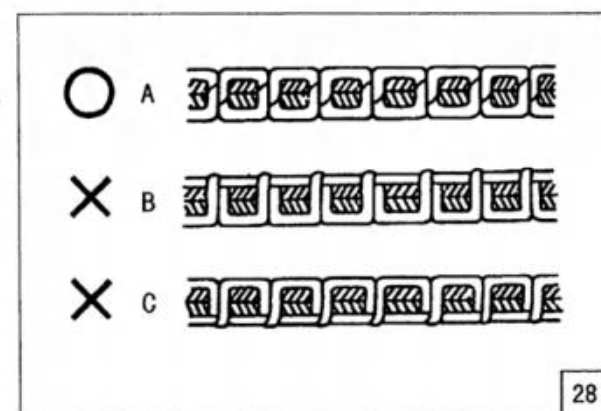

## 23. Tension of Upper Thread

Adjustment of the upper thread tension can be achieved by changing the pressure of the tension discs of the regulator, as well as the strength and operating range of the thread take-up spring.

(1) For one needle type: Pressure of the thread tension discs. For general fabric stitching, the desired tension can be obtained just by adjusting the pressure of the tension discs. To tighten, turn the thread tension nut to the right. To loosen, turn to the left (Fig.29). For two needle type: To tighten the pressure of thread tension discs, turn the thread tension nut 1 to the right. To loosen, turn the tension nut to the left (Fig.30).

(2) Strength of the thread take-up spring. Adjust the strength of the take-up spring according to the materials to be stitched.

Standard materials	.....Approx.	25g
Light materials	.....Approx.	20g
Heavy materials	.....Approx.	30g
How to adjust		

Leave the presser bar lifter down. Remove the faceplate. Loosen the small screw 2, 6 inside of the faceplate as shown of the upper thread tension regulator (one needle type) or of the thread tension controller (two needle type). Fit screw drive into the groove of the thread tension stud 3, or thread controller stud 5, and turn stud to the left to strengthen, and to the right to slacken. After adjusting, tighten the small screw and put the faceplate back on. (Fig.31, 32)

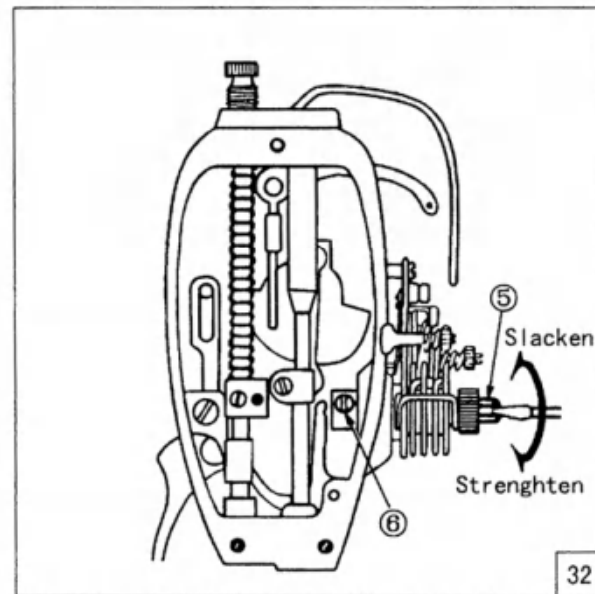
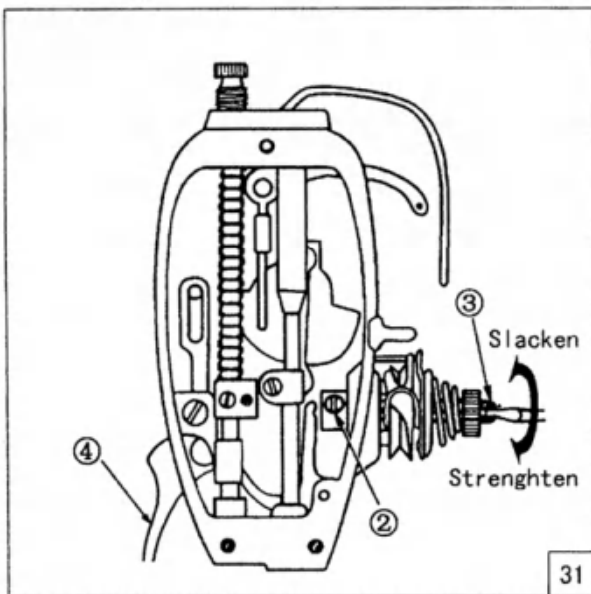
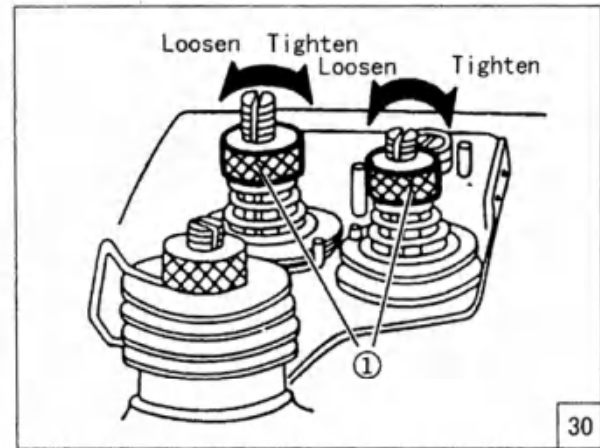
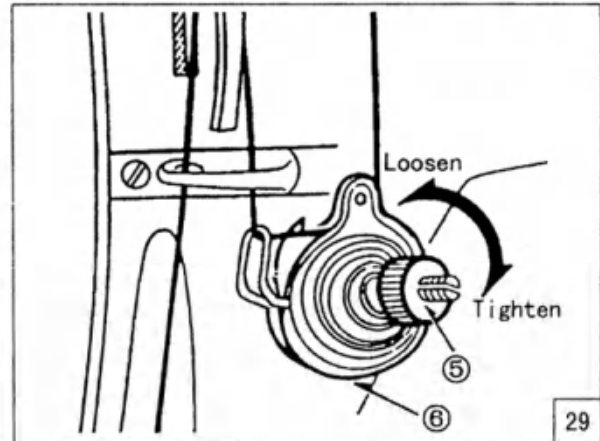

(3) The operating range can be measured when the take-up lever is at the highest position. When the upper thread is pulled, and the tension spring moves within the width of 8 mm, it is considered as standard. (Fig.33)

- Standard materials .....Approx. 8 mm
- Light materials.....8 mm or up
- Heavy materials.....8 mm or less

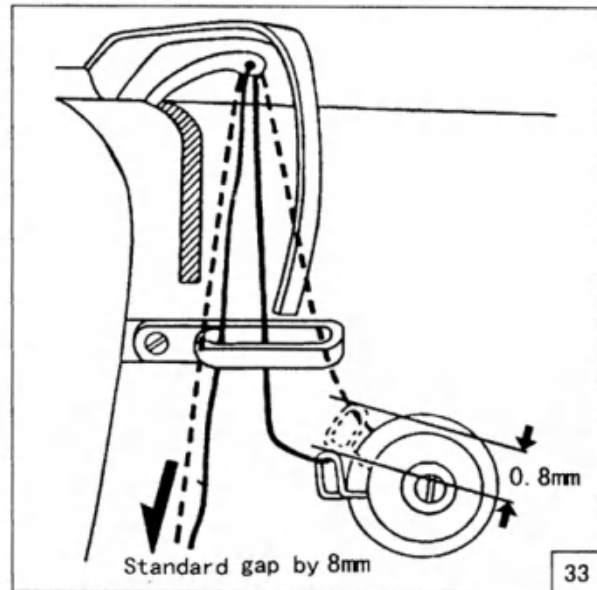

How to adjust (One needle type) (Fig. 34)

Lower the presser bar lifter. Loosen the thread tension regulator set screw 1. Fit the screwdriver into the groove of the tension regulator stud 3, and turn the stud to the right to small the operating range. Turn the stud to the left to large the operating range. After adjusted, tighten the screw.

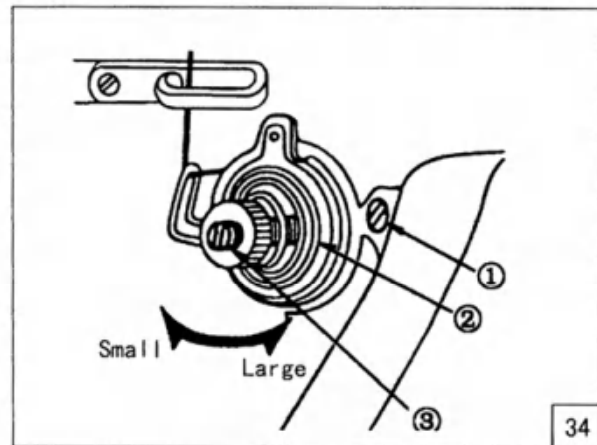

How to adjust (two needle type) (Fig. 35)

Loosen the thread controller set screw 1. Fit the screwdriver into the groove of the thread controller stud 3, and turn the stud to the right to small the operating range. Turn the stud to the left to range the operating range. After adjusting, tighten the screw.

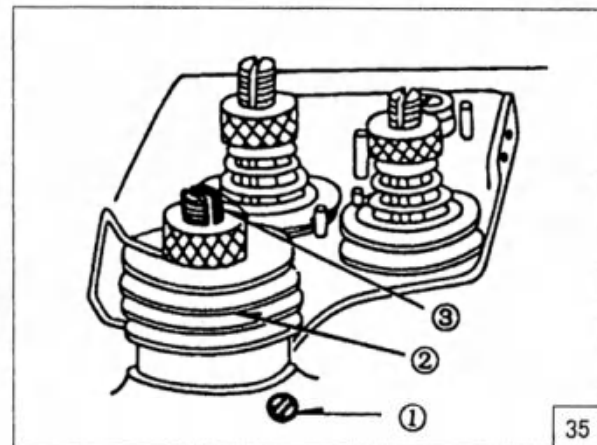

## 24. Tension of Lower Thread (Fig.36)

There is virtually no need to adjust the lower thread tension, except for special kind of fabrics or thread, when slight adjustment will be necessary.

- (1) Turn the balance wheel by hand, and stop when the thread take-up lever comes down to its lowest position.
- (2) Move the slide plate to that you find the thread tension screw 3 of the hook base.

(3) Fit the screwdriver into the hole 2 of the hook shaft bracket 3 as shown in Fig. 36. Turn the tension screw to the right to strengthen the thread tension.

(4) Turn the screw to the left to weaken the thread.

## 25. Adjustment of Feed Dog Height and Pressure of Presser on Materials

The feed dog height and pressure of presser on materials must be properly adjusted according to the materials to be sewn. In case of light materials: The material may be damaged if the feed dog is raised excessively or the pressure of presser on materials is too strong. In case of heavy materials: It will not make uniform stitching if the feed dog is not raised properly or the pressure of presser is too weak. (Fig. 37)

- Standard materials .....Approx. 1.0 mm
- Light materials.....Approx. 0.8 mm
- Heavy materials.....Approx. 1.2 mm

### (1) Adjustment of feed dog height (Fig. 38)

- 1) Lay down the machine bed toward the other side.
- 2) Remove the gearbox
- 3) Turn the balance wheel by hand and stop when the feed dog is raised to its highest position from the surface of needle plate.
- 4) Loosen the screw of feed lifting rockshaft crank.
- 5) Adjust the feed dog to the desired height moving the feed lifting rockshaft crank back and forth as per as arrow shown in Fig. 38
- 6) After adjusting, tighten the screw of feed lifting rockshaft.

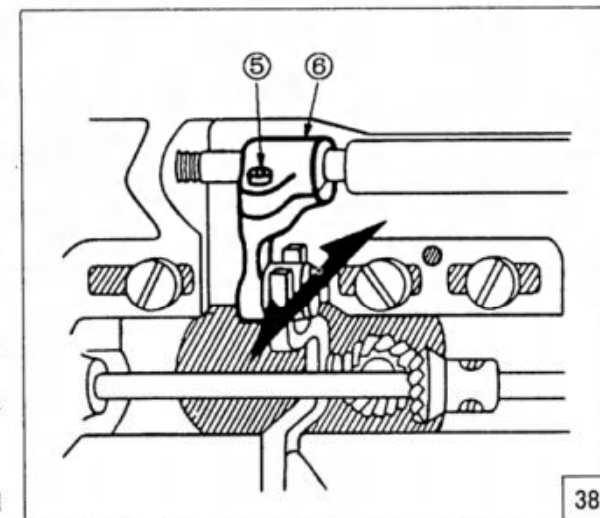
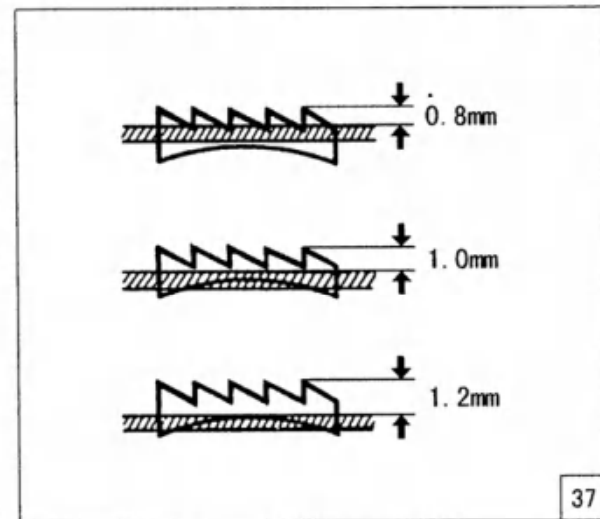
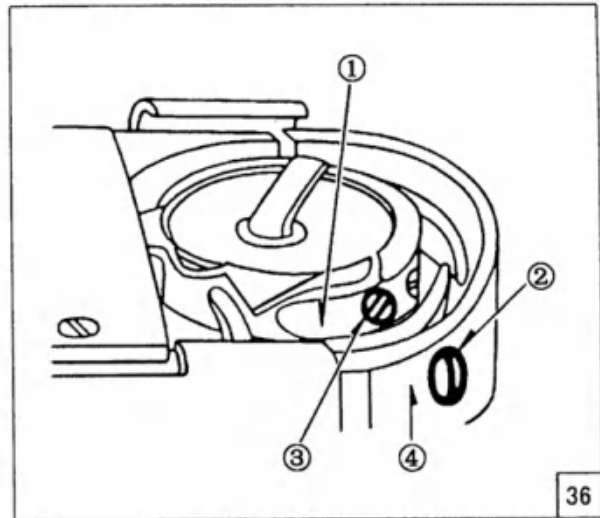

(2) Adjustment of pressure of presser foot  
(Fig. 39)

- 1) Turn the presser-regulating thumbscrew to the right to strengthen the pressure of presser foot.
- 2) Turn the screw to the left to loosen the pressure of presser foot.

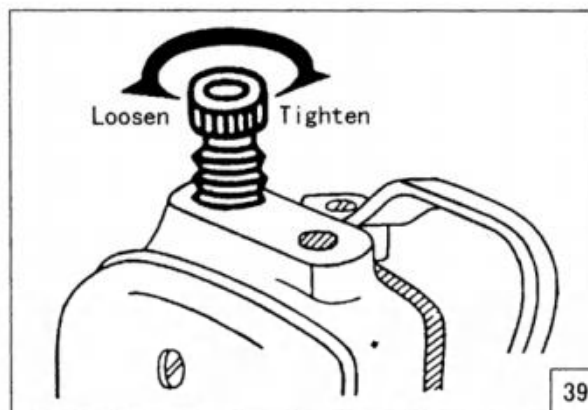

## 26. Proper Timing Between Hook and Needle

Place and adjust the hook in the condition described below in case of the thread gets entangled in the hook, or when its position is changed due to shock, or other causes, or when it is replaced with new one.

(1) How to remove the hook (Fig.40, 41, 42)

1) Turn the balance wheel by hand and stop when the thread take-up lever comes down to its lowest position.

2) Remove the slide plate, then take out the bobbin.

3) Remove the needle plate.

4) Remove the hook coverplate (front) (in case of two needle type, remove the hook cover plate (upper) both the front and back.)

5) Remove the hook opener screw 3, and then remove the opener 1.

6) Loosen the hook gib screw and remove the hook gib fixed in front of the hook body as shown in Fig 41.

7) Hold the latch lever up turning it slightly so that it can be taken out.

8) Remove the hook body center set screw 6 so that it can be taken out.

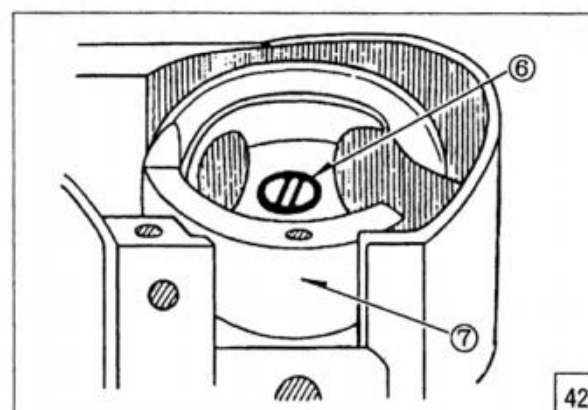
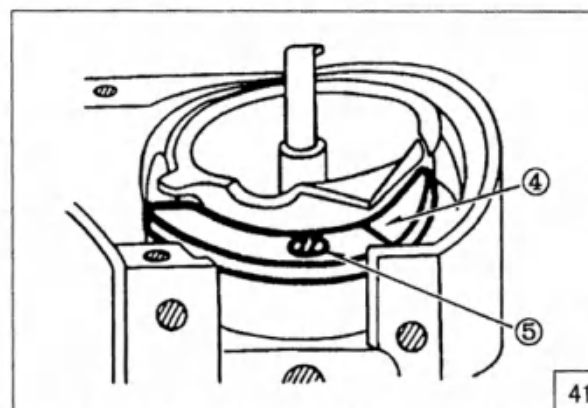
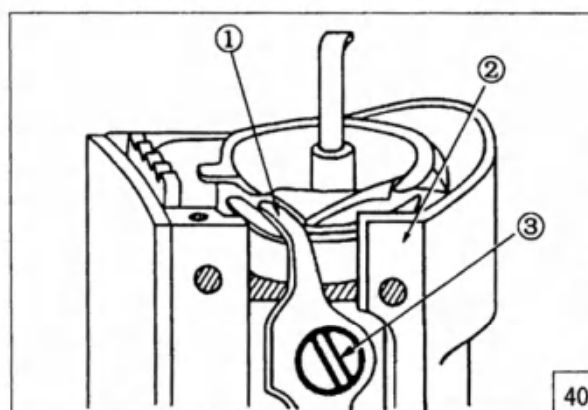

(2) How to place the hook (Fig 43, 44)

- 1) Place the hook in backward order from removing procedure.
- 2) When placing the hook body, remember to place it at the same position as it was taken out.
- 3) When inserting the hook base 3, hold the hook base cap 1 and turn it to the left as shown in Fig. 43, and fit the hook base bring into slot of the hook body on the inside of the other side.
- 4) When placing the needle plate, place the needle plate adjusting the hook base so that the tip of hook base fits into the hook finger of the needle plate as shown in fig. 44.

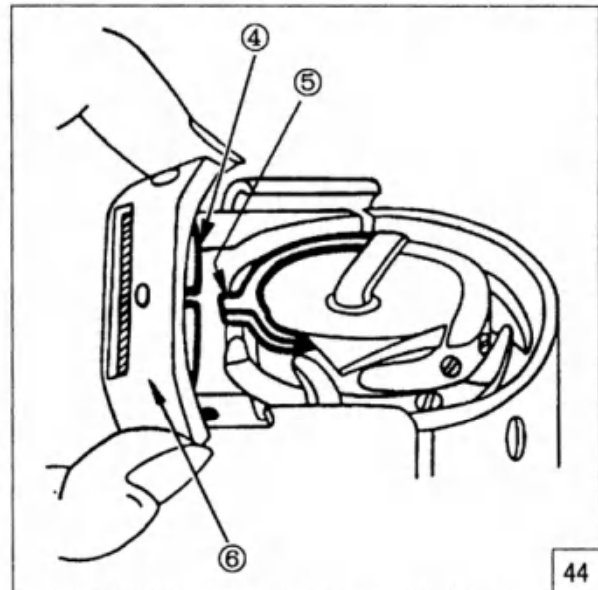
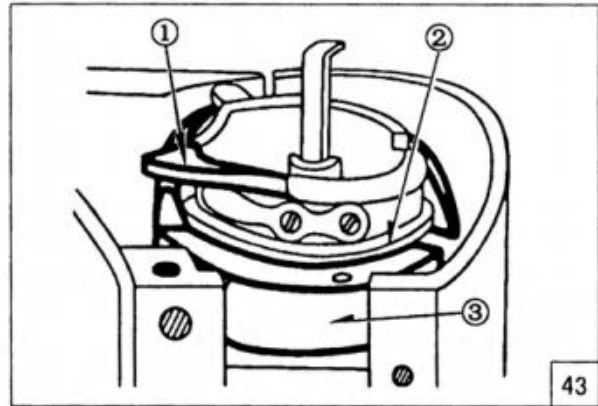

(3) The position of the hook and needle (Fig 45)

As shown in the Fig. 45, when the needle raised is 2.0 mm from its lowest position of the needle, the hook and needle should be as follows.

Upper part of the needle hole ..... Lower by 1.6mm from the tip of hook.

Tip of hook ..... At center of needle.

Gap between tip of hook and lateral face of needle ..... By 0.05mm.

Adjustment of the relative position of the hook and needle can be done as follows:

1) Adjustment of needle bar position (Fig. 46)

Adjust the needle bar timing so that the gap between the tip of hook and the upper part of needle hole will be 1.6 mm when the needle is raised by 2.0mm from its lowest position.

- A. Raise the needle bar by 2.0 mm from its lowest position turning the balance wheel by hand.
- B. Loosen the needle bar connecting stud screw 2.

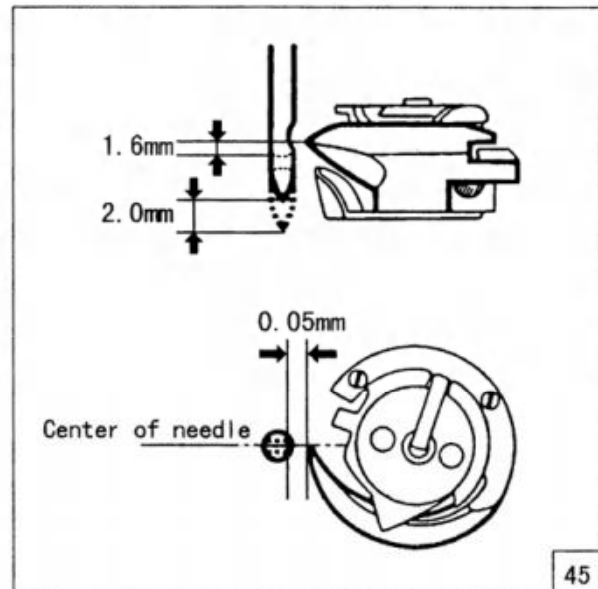



C. Adjust moving the needle bar 3 up and down so that the tip of hook comes at the position by 1.6 mm from the upper part of needle hole.

D. After adjusting the needle bar position, tighten the needle bar connecting stud screw.

2) Adjustment of tip of hook (Fig. 47, 48)

Adjust so that the tip of hook comes to the center of needle.

A. Remove the needle plate and slide plate.

B. Lay down the machine head toward the other side.

C. Remove the gearbox.

D. Loosen the two setscrews of the hook shaft gears.

E. Turn the balance wheel by hand, and stop when the needle is raised 2.0 mm from its lowest position.

F. Turn the hook by hand enabling the tip of hook to come to the center of needle.

G. After adjusting, tighten the two setscrews of the hook shaft gears.

H. Place the gearbox.

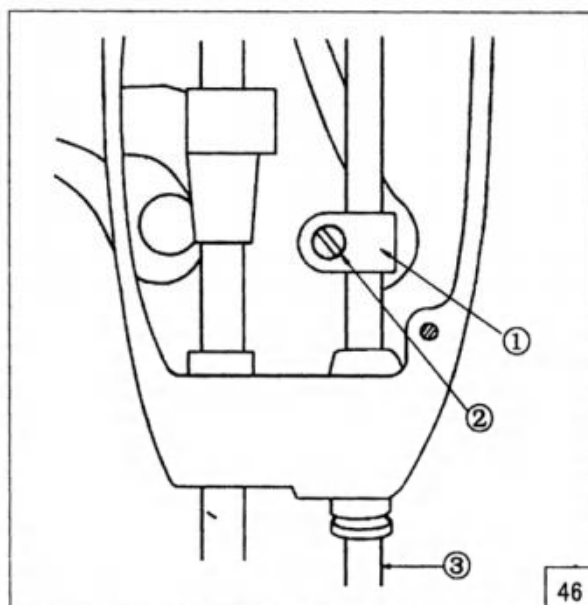

46

In case of one needle type

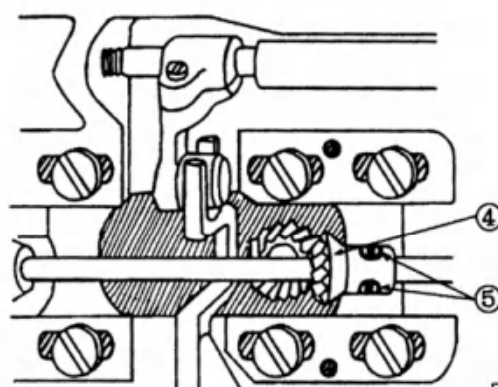

47

In case of two needle type

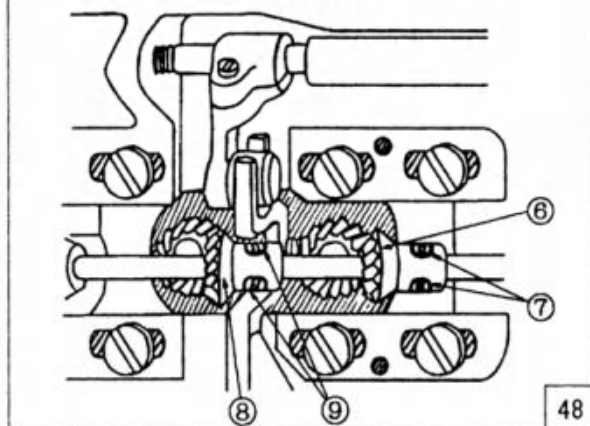

48

3) Adjust that the gap between the tip of hook and lateral side of the needle to come to 0.05 mm.

In case of one needle, there is virtually no

In case of two needle type

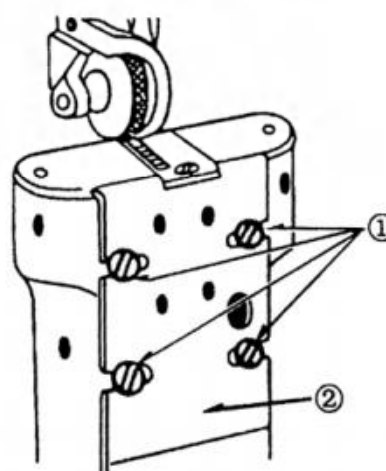

49

need to adjust it. However, in case of two needles, it is necessary to adjust it when changing the needle gauge sizes. (Fig. 49, 50)

- A. Loosen the screws 1 of the hook post cover plate 2 (front and back).
- B. Lay down the machine head toward the other side.
- C. Remove the gearbox.
- D. Loosen the hook shaft gear setscrews 4.
- E. Loosen the setscrews of hook shaft bracket 3, 5.
- F. Turn the balance wheel by hand, and stop when the needle is raised by 2.0 mm from its lowest position.
- G. Turn the hook by hand and bring the tip of hook to the center of needle.
- H. Move the hook shaft bracket of the right and left, so that the gap between the tip of hook and lateral side of needle is 0.05mm.
- I. After adjusting, tighten the setscrews of hook shaft gear and bracket.
- J. Place the gearbox.

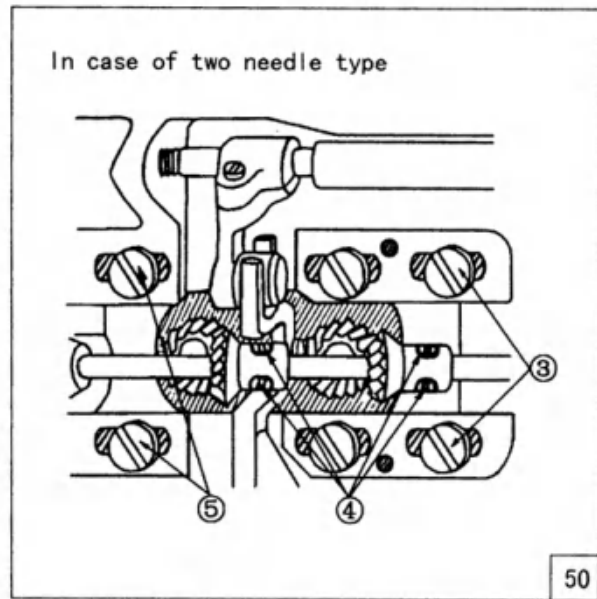

## 27. Proper Timing Between Hook and Opener (Fig.51)

- 1) Remove the slide plate.
- 2) Turn the balance wheel by hand, and stop at the position where the opener 7 and the needle plate are furthers point apart.
- 3) Check whether the gap between the part of hook base 6 and the opener is approx. 0.2 mm as shown in Fig.51. (There is a slight difference according to the thread to be used.)
- 4) In case the gap is too wide or narrow, adjust it fitting the screwdriver into a driver hole of the hook shaft bracket, then loosen the opener adjustable screw 8 and moving the opener to the right or left.
- 5) After adjustment, tighten the opener adjustable screw.

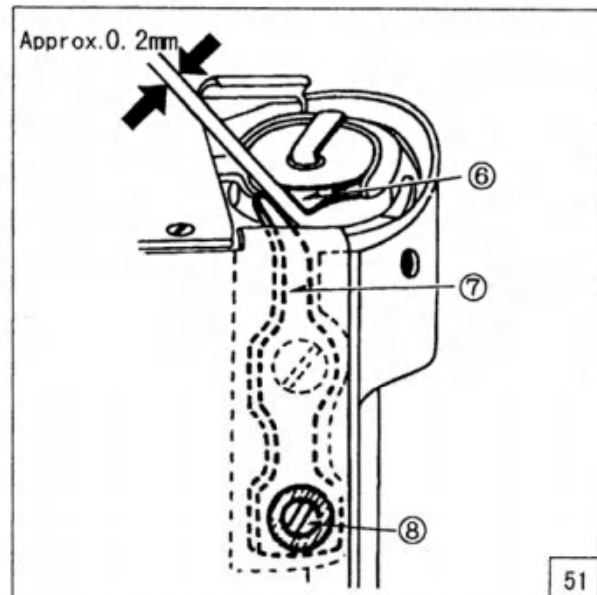

## 28. Proper Timing between Feed Dog and Needle (Fig.52)

The proper timing of the feed dog and needle will be as shown in Fig.52. When the material is feed through and the needle tip reach to the needle plate surface, just at the moment the feed dog begins to sink downward through the needle plate surface as shown in Fig. 52.

This adjustment is based on the feed dog height is at 1.0 mm

- (1) Loosen the arm side cover thumbscrew.
- (2) Move the side cover to the right, and open to upper side as shown in Fig. 52
- (3) Loosen the two setscrews 2 of the feed lifting cam 3.

(4) While holding the feed lifting cam by hand, turn the balance wheel 1 toward your side so that feeding device will be faster.

(5) In order to slow the feeding device, turn the balance wheel toward the other side.

(6) After adjustment, tighten the setscrews of the feed lifting cam.

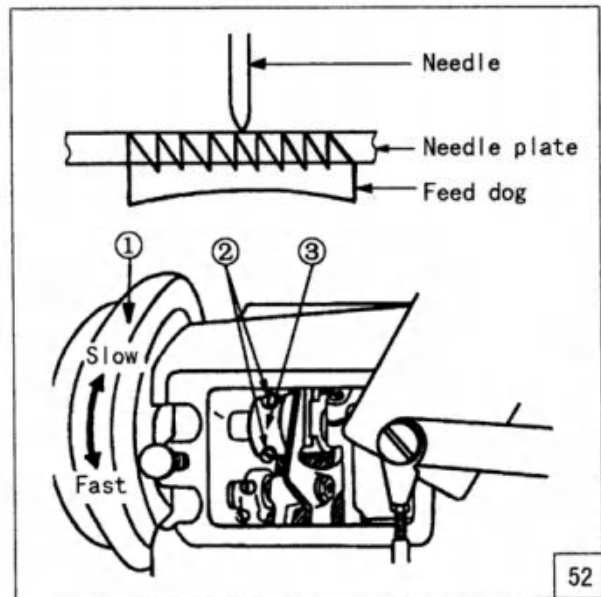

## 29. Cleaning and Lubrication (Fig.53, 54, 55, 56, 57)

### (1) Cleaning

The teeth of feed dog, hook, upper thread tension regulator discs, and thread controller discs are often covered by dust and lint causing improper operation and uneven stitching. Therefore, clean as often as necessary.

### (2) Lubrication

Lubrication is one of the most important phases of the machine maintenance. With improper lubrication, excess abrasion of machine parts will cause to shorten the life of the machine. Therefore, lubricate in the order as follows:

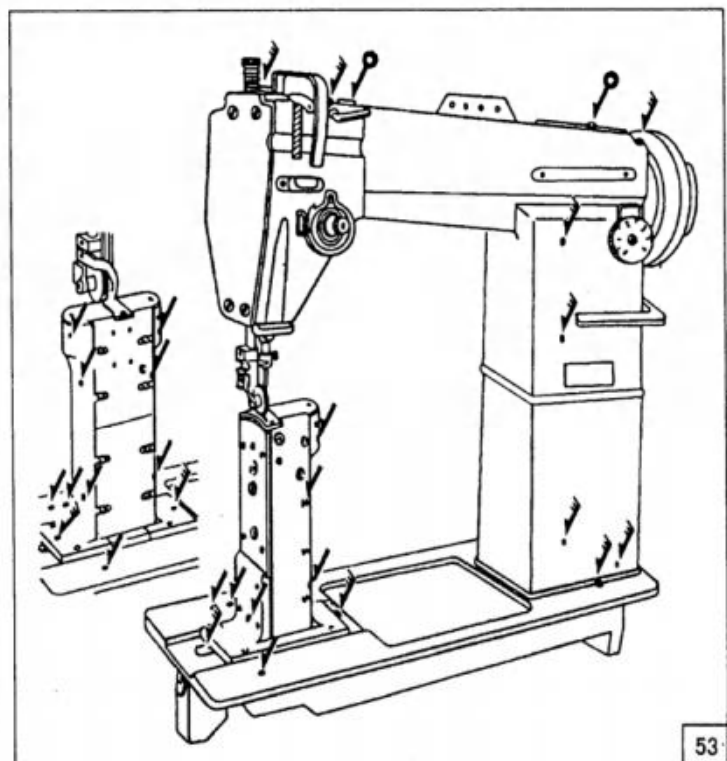

1) The number of times for lubrication.

A. Usual working ..... at 2-3 times per week.

B. Continuous working, every day ..... once each day

2) Volume of lubrication

Places  marks ..... approx. 5cc or more

Places  marks ..... approx. 5-6 drops

Places  marks ..... approx. 1-2 drops

3) Places where to lubricate

Lubricate the place where arrow is shown in Fig. 53.

(3) Grease

1) Remove the oil hole screws A and B. of the gearbox fixed to arm and hook shaft, then grease into the holes periodically.

2) Remove the gear case of the left side of hook shaft, then also grease into the gears sufficiently.

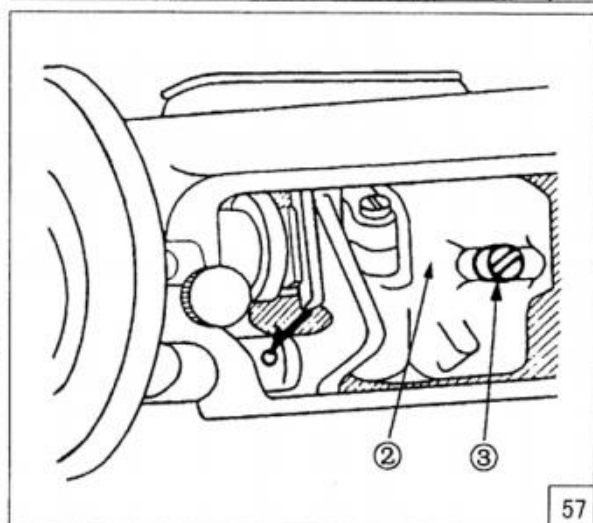
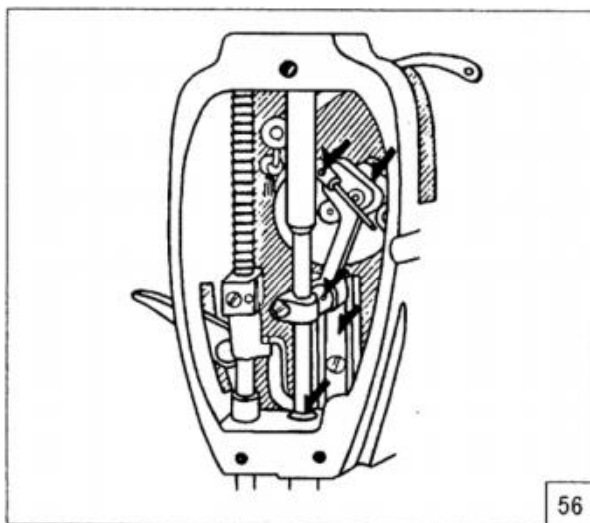
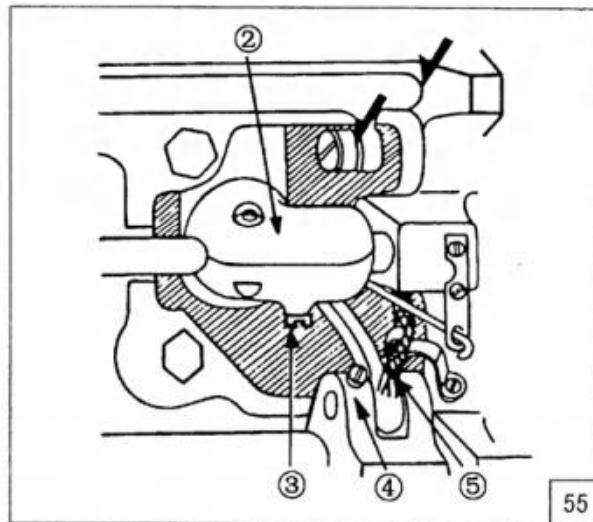
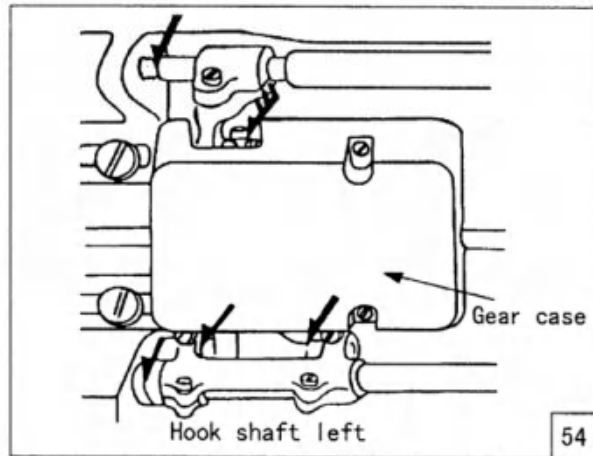

# A. ARM BED AND ITS ACCESSORIES

---

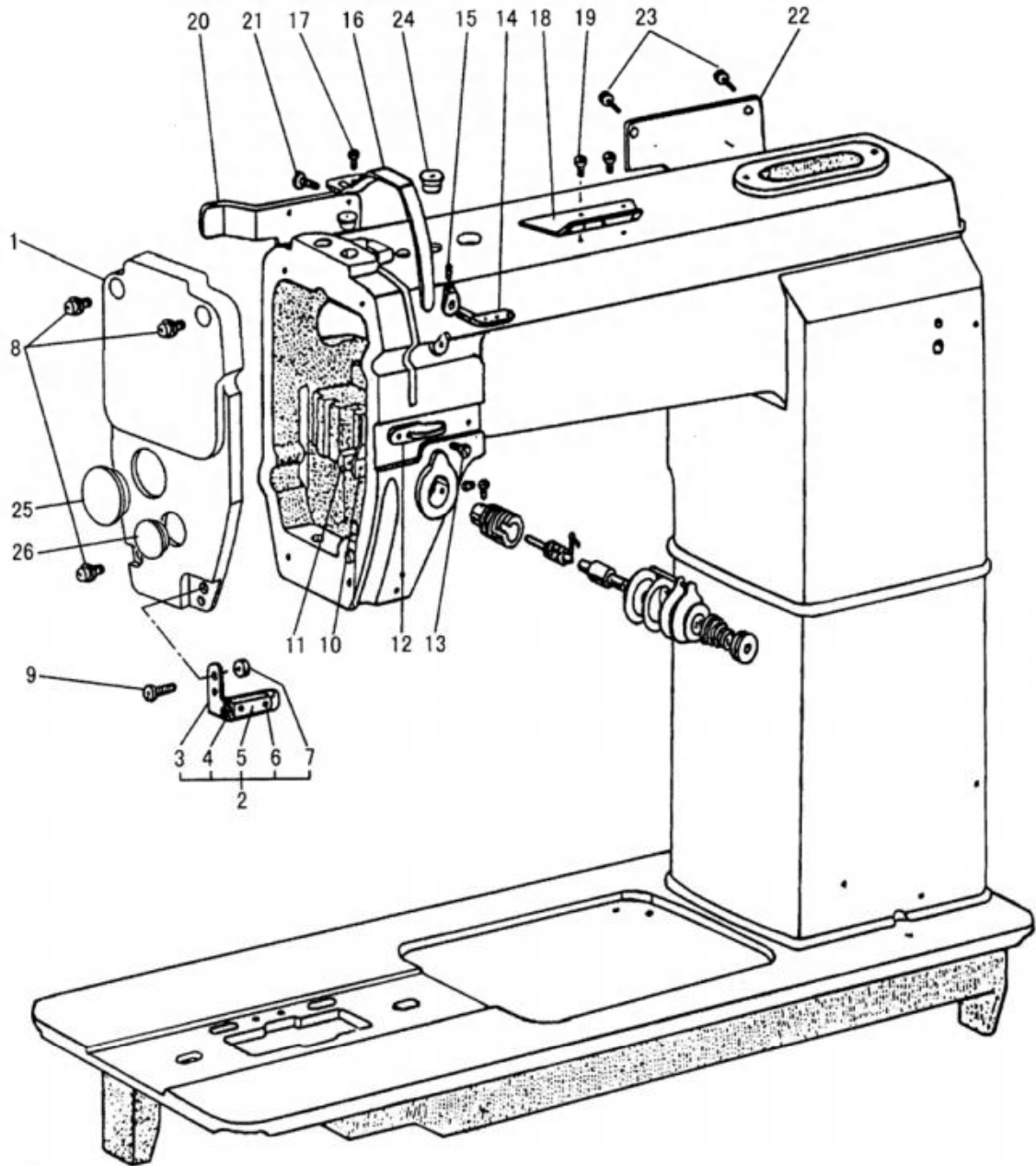

## A.ARM BED AND ITS ACCESSORIES

Fig. No.	Part No.	Description	GC24018	GC24018-1	Remarks
A01	H2400B2170	Face plate	1	1	
A02	H2407B0672	Thread guide (complete)	1	1	
A03	H2407B2021	Thread guide	1	1	
A04	H2407B2023	Felt	1	1	
A05	H2407B2022	Stopper	1	1	
A06	HA124B0713	Screw	2	2	SM3/32(56)×2.2
A07	HA7111N304	Nut	1	1	
A08	HA300B2160	Screw	3	3	SM11/64(40)×10
A09	HA300B2160	Screw	1	1	SM11/64(40)×10
A10	H2400B2050	Oil guard plate	1	1	
A11	H2400B2060	Spacer	1	1	
A12	H2400B2070	Thread guide	1	1	
A13	H2400B2080	Screw	2	2	SM3/16(28)×12.1
A14	HA100B2100	Thread guide	1		
A15	HA100B2110	Screw	1		SM11/64(40)×5.5
A16	H2400B2090	Thread take-up cover	1	1	
A17	HA300B2160	Screw	1	1	SM11/64(40)×10
A18	H2400B2100	Thread guide	1	1	
A19	HA700B2060	Screw	2	2	SM11/64(40)×8
A20	H2400B2110	Side cover	1	1	
A21	HA300B2170	Screw	2	2	SM11/64(40)×9
A22	H2415B0068	Arm side cover	1	1	
A23	HA300B2170	Screw	3	3	SM11/64(40)×9
A24	H2003M0067	Bushing cap	1	1	
A25	HA307B0673	Rubber plug	1	1	φ19
A26	HA307B0674	Rubber plug	1	1	φ11.8

## B. THREAD TENSION REGULATOR MECHANISM

---

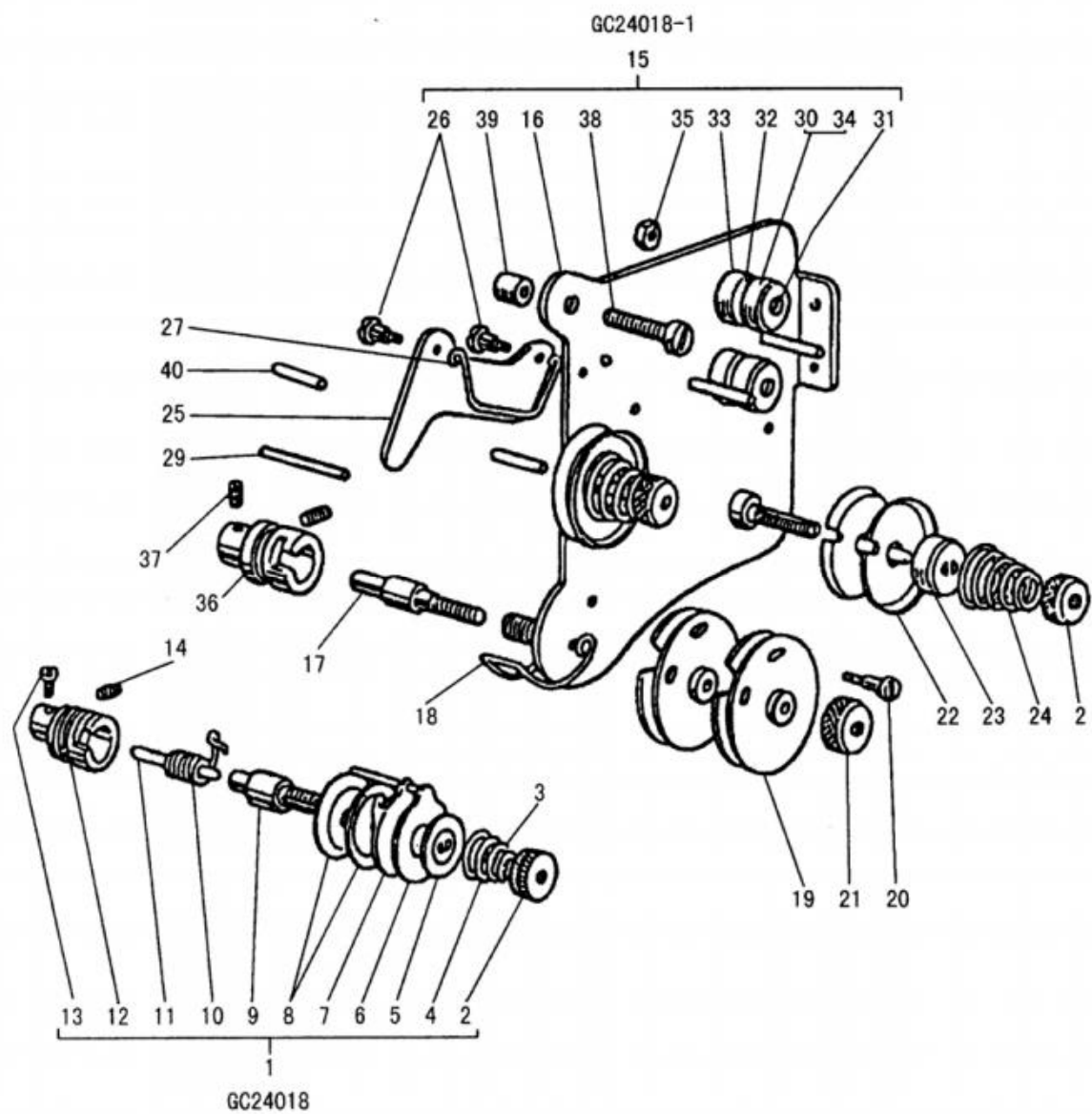

## B.THREAD TENSION REGULATOR MECHANISM

Fig. No.	Part No.	Description	GC24018	GC24018-1	Remarks
B01	H2404C0065	Thread tension regulator ( complete)	1		
B02	HA310B0701	Thumb nut ( complete)	1	2	
B03	HA115B7010	Stop plate	1	2	
B04	HA607B0068	Thread tension spring	1		
B05	HA310B0702	Thread tension releasing disc	1		
B06	H2404C0652	Stop plate	1		
B07	H2404C0653	Tension regulator bracket	1		
B08	HA310B0705	Tension disc	2		
B09	H2404C0654	Thread tension stud	1		SM1/4(40)×48.5
B10	H2404C0655	Thread take-up spring	1		
B11	H2404C0656	Thread tension releasing pin	1		
B12	HA310B0703	Regulator bushing	1		
B13	HA115B0708	Screw	1	1	SM9/64(40)×4
B14	HA300B2080	Screw	1		SM15/64(28)×6.8
B15	H2504C0065	Thread tension regulator ( complete)		1	
B16	H2504C0651	Mounting plate (complete)		1	
B17	H2504C0652	Thread tension stud		1	SM1/4(40)×47
B18	H2504C0653	Thread take-up spring		1	
B19	H2504C0654	Thread controller disc		2	
B20	H2504C0655	Screw		1	SM3/32(56)×11.5
B21	H2504C0658	Regulator thumb nut		1	
B22	H2504C0656	Tension disc		4	
B23	H2504C0657	Thread tension releasing disc		2	
B24	HA607B0068	Thread tension spring		2	
B25	H2504C0659	Tension releasing plate		1	
B26	H2504C6510	Screw		2	SM9/64(40)×6
B27	H2504C6511	Releasing spring		1	
B28	H2504C0121	Thread releasing pin		1	
B29	H2504C0122	Thread releasing pin		1	
B30	H2504C0131	Screw		2	
B31	H2504C0132	Pin		2	
B32	H2504C6514	Thread guide disc		2	
B33	H2504C6515	Guide blacket		2	
B34	H2504C6516	Tension spring		2	
B35	H2504C6517	Nut		2	SM9/64×40
B36	H2504C6518	Thread tension regulator		1	
B37	HA711B0681	Screw		1	SM9/64(40)×4.5
B38	HA7311C606	Screw		1	SM11/64(40)×15
B39	H2500C2020	Pipe		1	
B40	H2500C2030	Pin		1	



C. NEEDLE BAR AND TAKE-UP LEVER MECHANISM

---

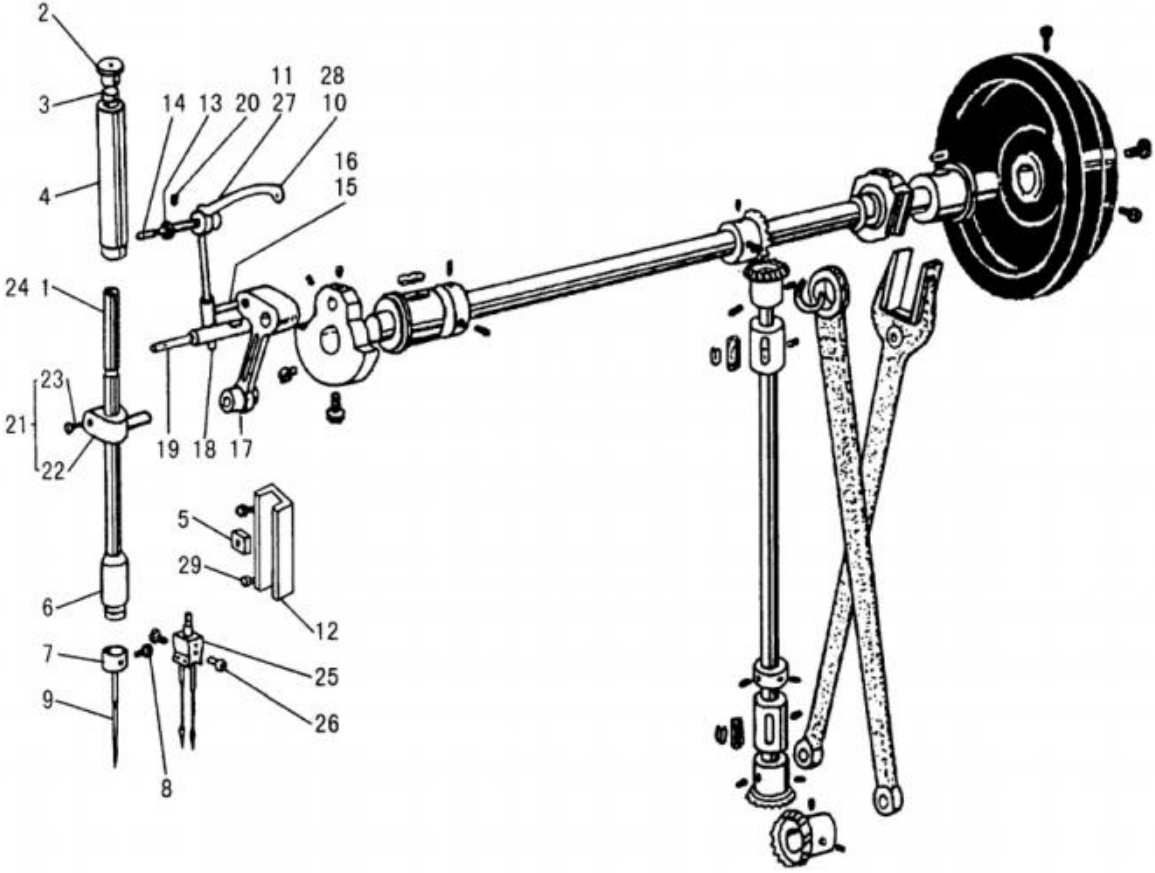

### C.NEEDLE BAR AND TAKE-UP LEVER MECHANISM

Fig. No.	Part No.	Description	GC24018	GC24018-1	Remarks
C01	H2404D0651	Needle bar	1		
C02	H2003M0067	Plug	1	1	
C03	HA100C2100	Felt	1	1	
C04	H2009B0067	Needle bar bushing (upper)	1	1	
C05	HA100C2200	Square block	1	1	
C06	HA300C2060	Needle bar bushing (under)	1	1	
C07	HA500C2030	Thread guide	1		
C08	HA100C2170	Screw	1		SM1/8(44)×4.5
C09	H2404D0653	Needle	1	2	DP×5 16#
C10	H2405D1011	Take-up lever (complete)	1		
C11	H24211D105	lever and side block (complete)	1		
C12	HA100C2180	Needle bar connecting link guide	1	1	
C13	H2405D1121	Take-up lever support stud	1	1	
C14	H2405D1122	Oil wick	1	1	
C15	H24211D305	Plug	1	1	
C16	H24211D405	Oil wick	1	1	
C17	H2405D1012	Needle bar link	1	1	
C18	H2405D0662	Crank pin	1	1	
C19	H2405D0663	Oil wick	1	1	
C20	H2405D0664	Screw	1	1	SM15/64(28)×14
C21	H2405D0665	Needle bar connecting stud (complete)	1	1	
C22	HA104C0658	Needle bar connecting stud (complete)	1	1	
C23	H2204C0651	Screw	1	1	SM9/64(40)×6.5
C24	H2504D0651	Needle bar		1	
C25	H2504D0021	Needle clamp		1	(3/32)
C25	H2504D0022	Needle clamp		1	(1/8)
C25	H2504D0023	Needle clamp		1	(5/32)
C25	H2504D0024	Needle clamp		1	(3/64)( 1/16)
C25	H2500D2030	Needle clamp		1	(3/8)
C26	H2504D0653	Screw		2	SM1/8(44)×5.3
C26	HA115B0708	Screw		2	SM9/64(40)×6
C26	H2404G0657	Screw		2	SM9/64(40)×6.5
C27	H25211D105	lever and side block (complete)		1	
C28	H2505D1011	Take-up lever (complete)		1	
C29	HA100C2190	Screw	2	2	SM11/64(40)×8

# D. UPPER SHAFT AND VERTICAL SHAFT MECHANISM

---

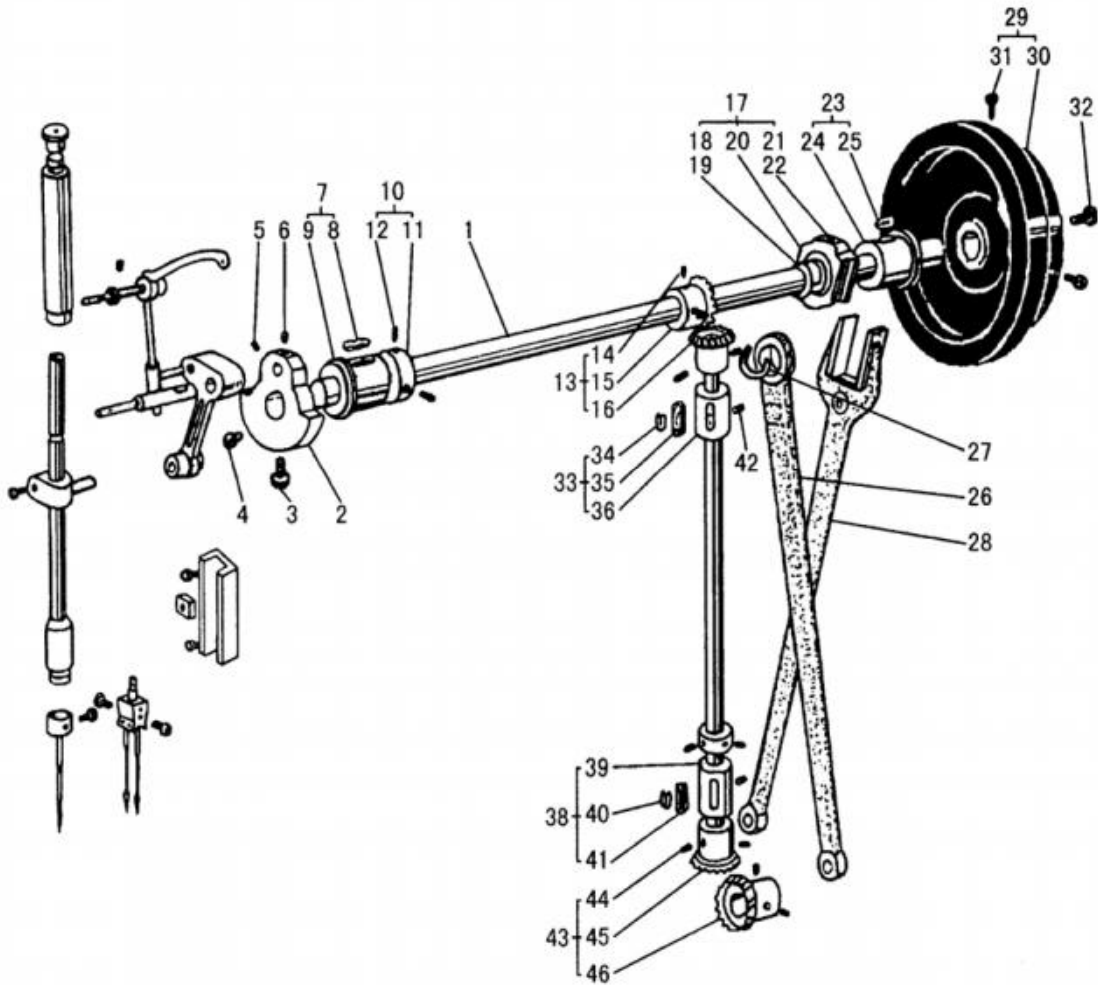

## D.UPPER SHAFT AND VERTICAL SHAFT MECHANISM

Fig. No.	Part No.	Description	GC24018	GC24018-1	Remarks
D01	H2404E0651	Upper shaft	1	1	
D02	H2404E0021	Crank	1	1	
D03	HA307C0662	Screw	1	1	
D04	HA108C0663	Screw	1	1	
D05	HA100C2070	Screw	1	1	SM9/32(28)×10
D06	HA100C2060	Screw	1	1	SM9/32(28)×13
D07	H2404E0653	Upper shaft bushing (left) (complete)	1	1	
D08	H2009B0742	Felt	1	1	
D08	H2009B0743	Felt	1	1	
D09	H2404E0031	Upper shaft bushing (left)	1	1	
D10	HA108G0066	Upper shaft collar (complete)	1	1	
D11	HA108G0661	Upper shaft collar	1	1	
D12	HA105D0662	Screw	2	2	SM1/4(40)×4
D13	HA113D4021	Bevel geal (upper) (complete)	1	1	
D14	HA108C0663	Screw	4	4	SM1/4(40)×7
D15	HA113D2112	Bevel geal (upper shaft)	1	1	
D16	HA113D2122	Bevel geal (vertical shaft)	1	1	
D17	H2404E0041	Feed cam (complete)	1	1	
D18	H24141E104	Feed cam	1	1	
D19	HA3411D308	Screw	2	2	SM15/64(28)×7
D20	HA3411D208	Feed cam ring	1	1	
D21	H20111C206	Felt	1	1	
D22	H20111C106	Spring	1	1	
D23	H2009B0073	Upper shaft bushing (right) (complete)	1	1	
D24	H2009B0732	Upper shaft bushing (right)	1	1	
D25	H2009B0731	Felt	1	1	
D26	H24142E104	Crank rod	1	1	
D27	HA112D3012	C-type stopper	1	1	
D28	H2404E0655	Feed forked conection	1	1	
D29	H2404E0656	Pulley (complete)	1	1	
D30	H2404E0061	Pulley	1	1	
D31	HA110D0672	Screw	2	2	SM15/64(28)×12
D32	HA100D2080	Screw	1	1	SM11/32(28)×10
D33	H2009B0071	Vertical shaft bushing upper (complete)	1	1	
D34	H2009B0712	Felt	1	1	
D35	H2009B0711	Felt	1	1	
D36	H2009B0713	Vertical shaft bushing upper	1	1	
D37	H2405E1011	Vertical shaft bushing	1	1	
D38	H2009B0072	Vertical shaft bushing under (complete)	1	1	
D39	H2009B0721	Vertical shaft bushing under	1	1	
D40	H2009B0712	Felt	1	1	
D41	H2009B0711	Felt	1	1	
D42	HA100C2020	Screw	2	2	SM15/64(28)×14

## D.UPPER SHAFT AND VERTICAL SHAFT MECHANISM

Fig. No.	Part No.	Description	GC24018	GC24018-1	Remarks
D43	HA113D4022	Bevel geal (under) (complete)	1	1	SM1/4(40)×7
D44	HA108C0663	Screw	4	4	
D45	HA113D2222	Bevel geal (under) (vertical shaft)	1	1	
D46	HA113D2212	Bevel geal (under) (lewer shaft)	1	1	

# E. STITCH REGULATOR MECHANISM

---

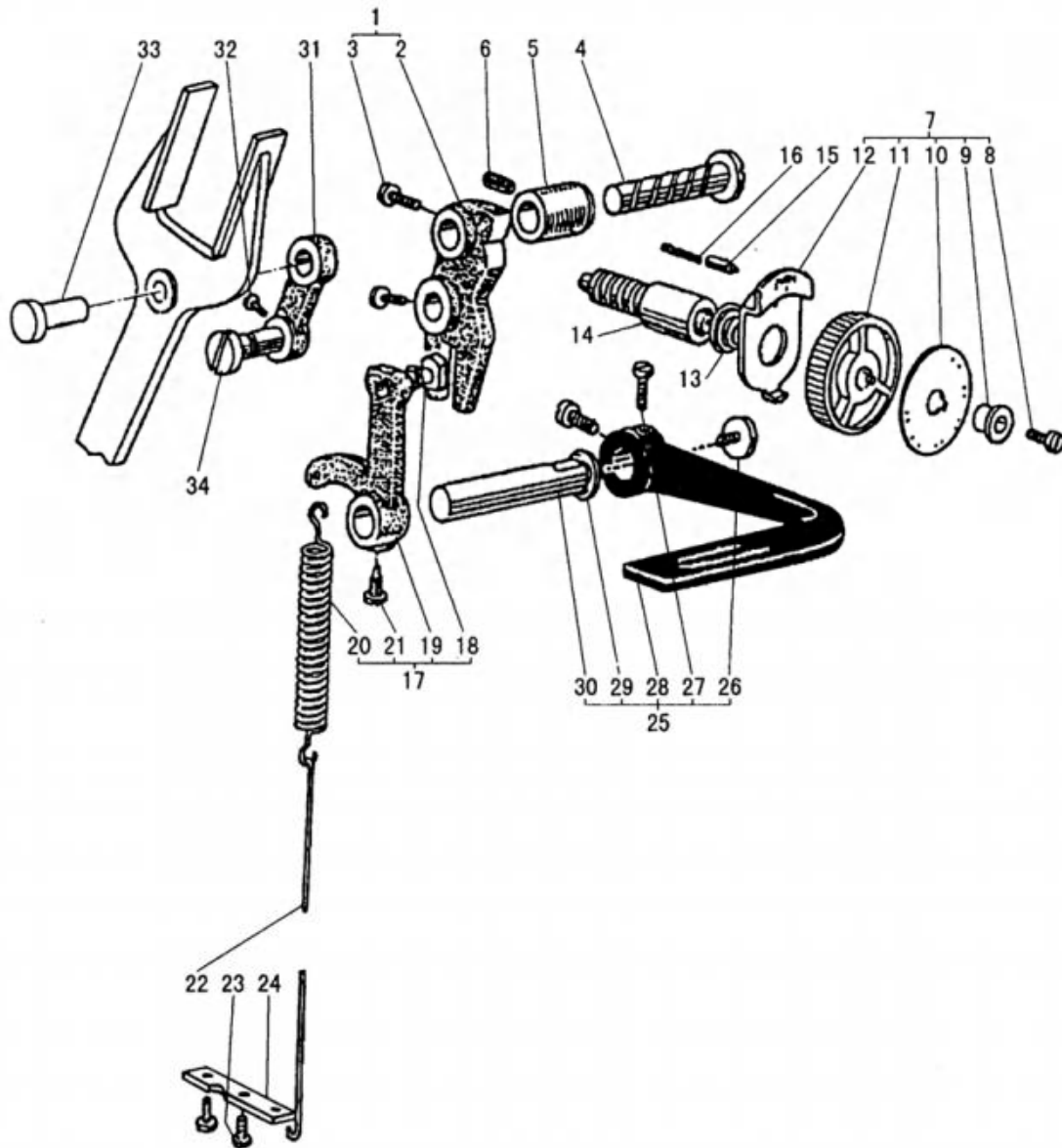

## E.STITCH REGULATOR MECHANISM

Fig. No.	Part No.	Description	GC24018	GC24018-1	Remarks
E01	H2404F0065	Feed regulator (complete)	1	1	
E02	H2404F0651	Feed regulator	1	1	
E03	HA104F0654	Screw	2	2	SM15/64(28)×10
E04	HA100F2040	Shaft	1	1	
E05	H2400F2020	Bushing	1	1	
E06	HA100C2020	Screw	1	1	SM15/6(28)×14
E07	H2400F2030	Feed screw (complete)	1	1	
E08	HA720F0686	Screw	1	1	SM3/16(28)×18
E09	HA720F0685	Bushing	1	1	
E10	HA720F0684	Stitch length indicating plate	1	1	
E11	HA7421F120	Dial	1	1	
E12	HA720F0683	Stopper pin release lever	1	1	
E13	HA720F0687	Coil spring	1	1	
E14	HA720F0681	Screw bar	1	1	
E15	HA700F2030	Pin	1	1	
E16	HA100F2090	Spring	1	1	
E17	H2004F0067	Feed regulating arm (complete)	1	1	
E18	HA115F4011	Square block (complete)	1	1	
E19	HA115F0691	Feed regulating arm	1	1	
E20	H2004F0671	Spring	1	1	
E21	HA100F2130	Screw	1	1	SM15/64(28)×6.7
E22	H2400F2040	Knee lifter rod	1	1	
E23	HA100C2190	Screw	2	2	SM11/64(40)×8
E24	H2400F2050	Bracket	1	1	
E25	H2000F2020	Reverse lever(complete)	1	1	
E26	HA113F0683	Screw	1	1	SM3/16(28)×6.5
E27	HA104F0654	Screw	2	2	SM15/64(28)×10
E28	HA309F0671	Reverse lever	1	1	
E29	HA100F2110	Spring washer	1	1	
E30	H2005F0065	Shaft	1	1	
E31	HA104F0652	Feed connection link	1	1	
E32	HA104F0654	Screw	1	1	SM15/64(28)×10
E33	HA104F0651	Shaft	1	1	
E34	HA104F0653	Shaft	1	1	

# F. PRESSER FOOT AND KNEE LIFTER MECHANISM

---

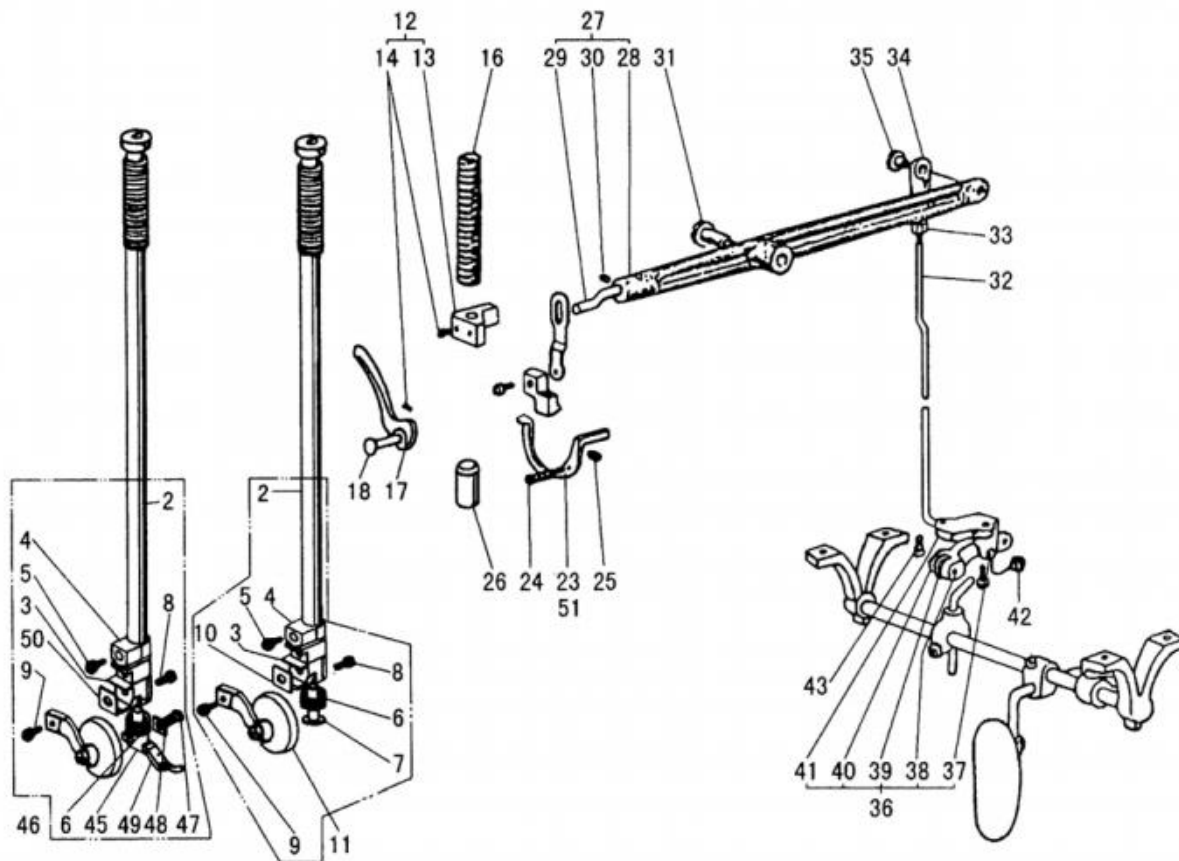



## F. PRESSER FOOT AND KNEE LIFTER MECHANISM

Fig. No.	Part No.	Description	GC24018	GC24018-1	Remarks
F01	H2404G0065	Roller Presser bar (complete)	1		
F02	H2404G0651	Presser bar	1	1	
F03	H2404G0652	Bracket	1	1	
F04	H2404G0653	Stopper	1	1	
F05	H2404G0654	Screw	1	1	SM15/64(28)×8
F06	H2404G0655	Spring	1	1	
F07	H2404G0656	Spring stud	1		
F08	H2404G0657	Screw	2	2	SM9/64(40)×3.5
F09	H2404G0658	Screw	1	1	SM11/64(32)×7.7
F10	H2404G0659	Spacer	1		
F11	H2405G0066	Roller Presser (complete)	1		
F12	H2406G0067	Presser bar holder (complete)	1	1	
F13	H2406G0671	Presser bar holder	1	1	
F14	HA3411D308	Screw	2	2	SM15/64(28)×7
F15	H2400G2040	Presser releasing thumb screw	1	1	SM1/2(28)×33
F16	H2400G2050	Presser spring	1	1	
F17	H2000I2060	Presser bar lefter	1	1	
F18	H2000I2070	Presser bar lefter pin	1	1	
F19	H2409G0068	Knee lifter lever link (complete)	1	1	
F20	H2409G0682	Knee lifter lever link	1	1	
F21	H2409G0681	Knee lifter lever	1	1	
F22	H2409G0683	Screw	1	1	SM3/16(32)×6
F23	H2400G2070	Tension releasing lever	1		
F24	H2400G2080	Screw	1	1	SM11/64(40)×23.5
F25	H2400G2090	Coil spring	1	1	
F26	HA300H2090	Presser bar bushing	1	1	
F27	H2413G0069	Knee lifter lever (complete)	1	1	
F28	H2413G0691	Knee lifter lever	1	1	
F29	H2413G0692	Pin	1	1	
F30	HA3411D308	Screw	1	1	SM15/64(28)×7
F31	H2000I2130	Screw	1	1	SM15/64(24)×11
F32	H2414G0701	Knee lifter lever connection rod	1	1	
F33	H2000I2160	Nut	1	1	
F34	H2000I2150	Knee lifter lever joint	1	1	
F35	H2000I2140	Screw	1	1	SM15/64(28)×5.8
F36	H2415G0071	Presser bar lever	1	1	
F37	H605050180	Pin	1	1	GB/T119.2 5×18
F38	H609060220	Spring pin	1	1	GB/T879.1 6×22
F39	H2415G0712	Roller	1	1	
F40	H2415G0711	Knee lifter lever joint	1	1	
F41	H2021I0065	Bracket	1	1	
F42	H2400G2130	Spring	1	1	
F43	H2000I2200	Screw	2	2	SM11/64(40)×12

## F.PRESSER FOOT AND KNEE LIFTER MECHANISM

Fig. No.	Part No.	Description	GC24018	GC24018-1	Remarks
F44	H2504G0651	Roller Presser bar (complete)		1	(3/32)
F45	H2504G0011	Spring stud		1	
F46	H2504G0012	Roller Presser (complete)		1	
F47	H2504G0013	Screw		1	SM11/64(32)×7
F48	H2504G0014	Spacer		1	
F49	H2504G0021	Presser foot		1	(3/32)
F49	H2504G0022	Presser foot		1	(1/8)
F49	H2504G0023	Presser foot		1	(5/32)
F49	H2504G0024	Presser foot		1	(1/16)(3/64)
F50	H2504G0041	Spacer		1	(3/32)(1/8)(5/32)
F50	H2504G0042	Spacer		1	(3/64)(1/8)
F50	H2404G0659	Spacer		1	(1/16)(5/32)
F51	H2500G2020	Tension releasing lever		1	

# G. LOWER SHAFT AND FEED ROCK SHAFT MECHANISM

---

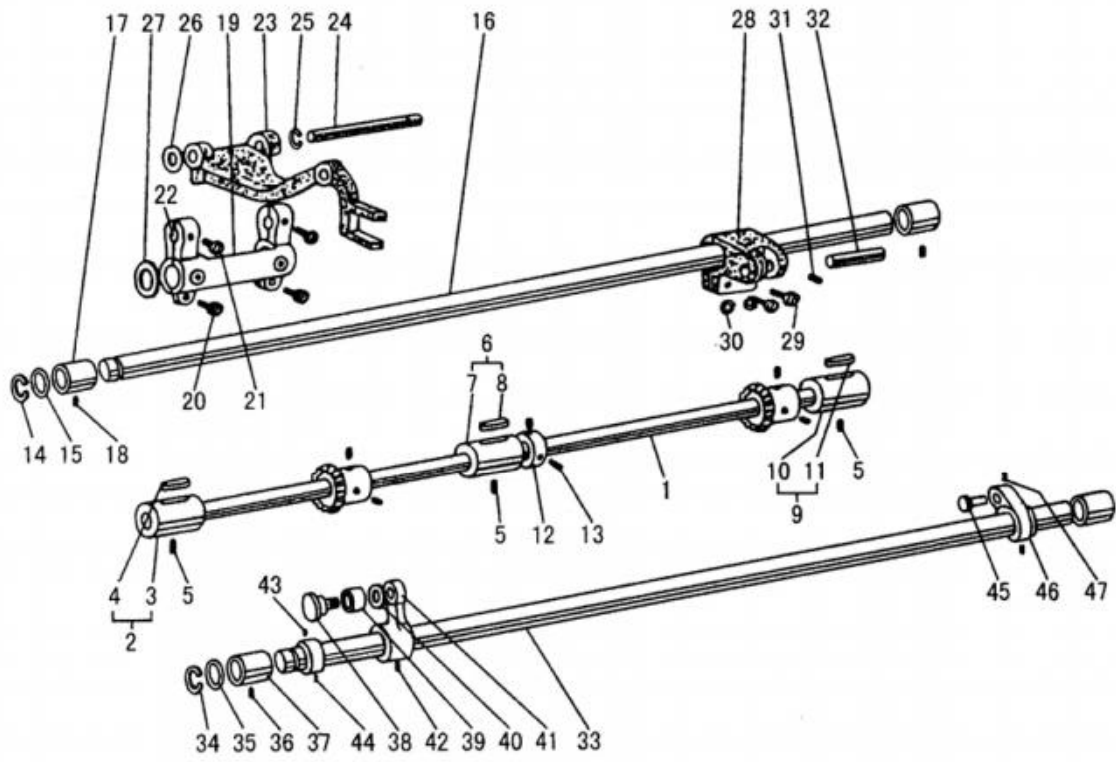

## G.LOWER SHAFT AND FEED ROCK SHAFT MECHANISM

Fig. No.	Part No.	Description	GC24018	GC24018-1	Remarks
G01	H2404H0651	Lower shaft	1	1	
G02	H2009B0072	Lower shaft bushing left (complete)	1	1	
G03	H2009B0721	Lower shaft bushing left	1	1	
G04	H2009B0711	Felt	1	1	
G04	H2009B0712	Oil wick	1	1	
G05	HA3411D308	Screw	3	3	SM15/64(28)×7
G06	H2009B0075	Lower shaft bushing middle (complete)	1	1	
G07	H2009B0751	Lower shaft bushing middle	1	1	
G08	H2009B0711	Felt	1	1	
G09	H2406H0067	Lower shaft bushing right (complete)	1	1	
G10	H2406H0671	Lower shaft bushing right	1	1	
G11	H2009B0711	Felt	1	1	
G12	HA305E0661	Collar	1	1	
G13	HA305E0662	Screw	2	2	SM15/64(28)×4.5
G14	H007009150	C-type stopper	1	1	GB/T894.1 15
G15	HA100G2130	Washer	1	1	
G16	H2405H1011	Feed rock shaft	1	1	
G17	H2009B0069	Feed rock shaft bushing(left)	2	2	
G18	HA100C2020	Screw	2	2	SM15/64(28)×14
G19	H24241H105	Feed rock shaft crank	1	1	
G20	HA111G0683	Screw	2	2	SM11/64(40)×12
G21	HA100C2190	Screw	2	2	SM11/64(40)×8
G22	H609015060	Spring pin	1	1	GB/T879.1 1.5×6
G23	H24242H205	Feed bar	1	1	
G24	H2405H1043	Feed bar shaft	1	1	
G25	H007013050	E-type stopper	1	1	GB/T896 5
G26	H2405H1044	Washer	1	1	
G27	H2405H0665	Slide Washer	1	1	
G28	H24221H105	Feed rock shaft (right)	1	1	
G29	HA111G0683	Screw	2	2	SM11/64(40)×12
G30	H24221H205	Washer	2	2	
G31	HA100B2110	Screw	1	1	SM11/64(40)×5.5
G32	H2405H0663	Pin	1	1	
G33	H2405H0666	Feed lifting rock shaft	1	1	
G34	H007009150	C-type stopper	1	1	GB/T894.1 15
G35	HA100G2130	Washer	1	1	
G36	HA100C2020	Screw	2	2	SM15/64(28)×14
G37	H2009B0069	Feed lifting rock shaft bushing	2	2	
G38	HA305G1012	Shaft	1	1	
G39	HA310G3011	Square block	1	1	
G40	HA310G3012	Washer	1	1	
G41	HA305G1011	Feed lifting crank left	1	1	
G42	HA7311C606	Screw	1	1	SM11/64(40)×15

## G.LOWER SHAFT AND FEED ROCK SHAFT MECHANISM

Fig. No.	Part No.	Description	GC24018	GC24018-1	Remarks
G43	HA108G0661	Coller	1	1	
G44	HA105D0662	Screw	2	2	SM1/4(40)×4
G45	HA100G2070	Shaft	1	1	
G46	H2410H1071	Feed lifting crank right	1	1	
G47	HA104G0012	Screw	2	2	SM3/16(28)×12

# H. HOOK SADDLE MECHANISM

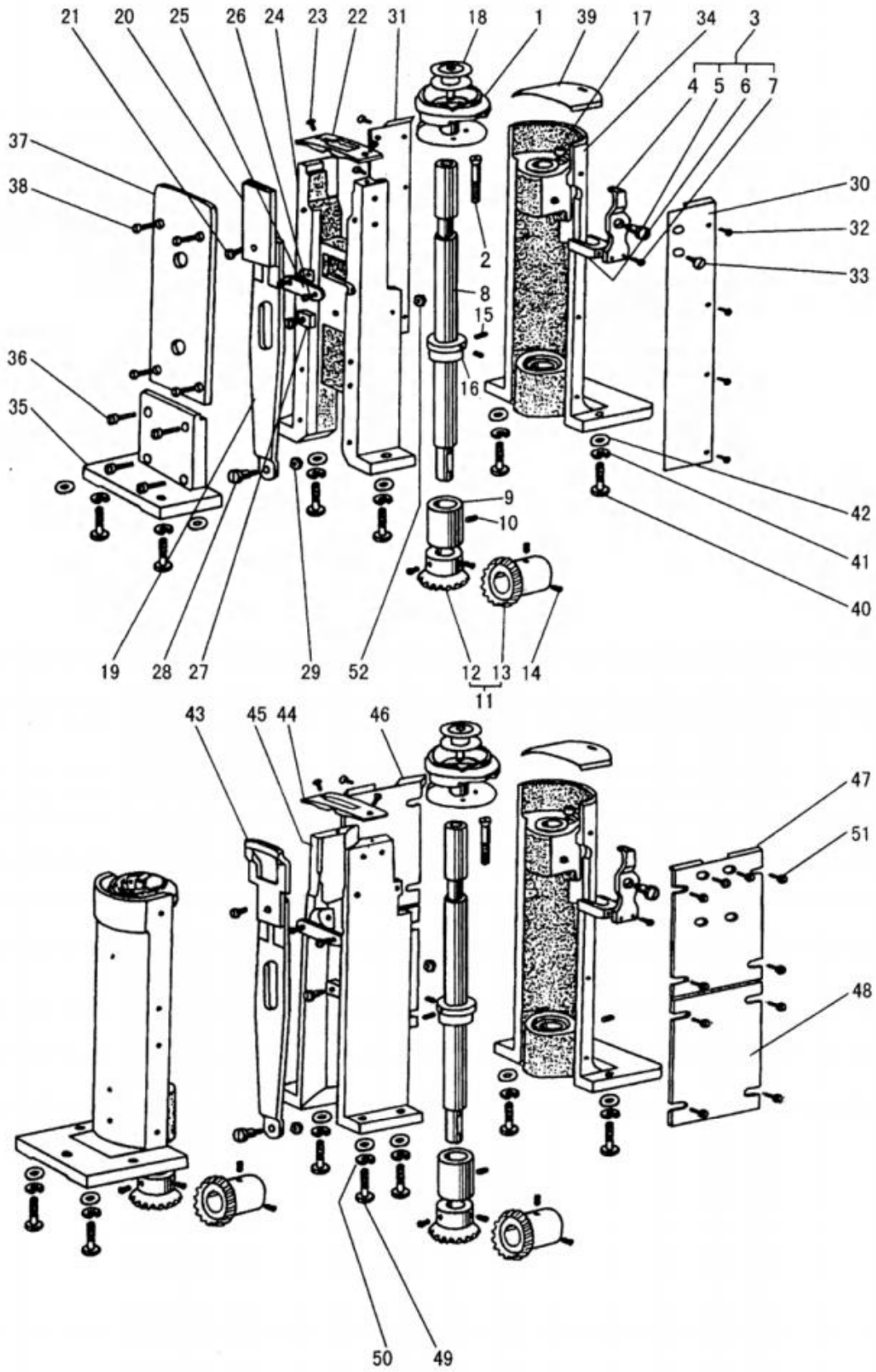

## H.HOOK SADDLE MECHANISM

Fig. No.	Part No.	Description	GC24018	GC24018-1	Remarks
H01	H2404I0651	Hook complete	1	2	
H02	H2404I0652	Screw	1	2	SM9/64(40)×27
H03	H2404I0653	Opener(comeplete)	1	2	
H04	H2404I0031	Opener	1	2	
H05	H2404I0032	Screw	1	2	SM9/32(28)×5.5
H06	H2404I0033	Opener bracket	1	2	
H07	H2404I0034	Screw	1	2	SM9/64(40)×8.5
H08	H2404I0655	Hook shaft	1	2	
H09	H2404I0656	Hook shaft bushing	1	2	
H10	HA100B2110	Screw	1	2	SM11/64(40)×5.5
H11	H2404I0657	Bevel gear(comeplete)	1	2	
H12	H2404I0071	Bevel gear (hook shaft)	1	2	
H13	H2404I0072	Bevel gear (lower shaft)	1	2	
H14	HA105D0662	Screw	4	8	SM1/4(40)×4
H15	HA105D0662	Screw	2	4	SM1/4(40)×4
H16	H2404I0081	Coller	1	2	
H17	H2404I0659	Felt	1	2	
H18	H2400I2020	Bobbin	1	2	
H19	H2406I0661	Feed plate	1	1	
H20	H2406I0662	Feed dog	1		
H21	HA300B2130	Screw	1	1	SM11/64(40)×5.5
H22	H2406I0663	Needle plate	1		
H23	H2406I0664	Screw	2	2	SM9/64(40)×7.5
H24	H2406I0665	Feed plate set bracket	1		
H25	H2406I0666	Supporter plate	1	1	
H26	HA300B2190	Screw	2	2	SM11/64(40)×6.5
H27	H2406I0667	Square block(comeplete)	1	1	
H28	H2400I2040	Screw	1	1	SM11/64(40)×6.5
H29	H2000M0120	Nut	1	1	
H30	H2400I2050	Cover plate	1		
H31	H2400I2060	Cover plate	1		
H32	H2400I2070	Screw	8		SM9/64(40)×6
H33	H2400I2080	Screw	3	4	SM11/64(4.37)×40×4
H34	H2404I0654	Hook shaft supporter	1	2	
H35	H2400I2090	Side cover bracket	1		
H36	HA111G0683	Screw	4		SM11/64(40)×12
H37	H2400I2100	Rear cover plate	1		
H38	HA100C2190	Screw	4		SM11/64(40)×8
H39	H2400I2110	Slide plate	1	2	
H40	H2400I2120	Screw	6	6	SM5/16(24)×26
H41	H005008080	Spring washer	6	8	GB/T93 8
H42	H005004080	Washer	6	6	GB/T848 8
H43	H2504I0011	Feed dog		1	(3/32)(1/16)(3/64)

## H.HOOK SADDLE MECHANISM

Fig. No.	Part No.	Description	GC24018	GC24018-1	Remarks
H43	H2504I0012	Feed dog		1	(1/8) (5/32)
H44	H2504I0021	Needle plate		1	(3/32)
H44	H2504I0022	Needle plate		1	(1/8)
H44	H2504I0023	Needle plate		1	(5/32)
H44	H2504I0024	Needle plate		1	(1/16)
H44	H2504I0025	Needle plate		1	(3/64)
H45	H2504I0653	Feed plate set bracket		1	
H46	H2500I2020	Cover plate		1	
H47	H2500I2030	Cover plate		1	
H48	H2500I2040	Cover plate		2	
H49	H2500I2050	Screw		2	SM1/4(24)×16.5
H50	H005004080	Washer		2	GB/T848 8
H51	HA7311CH06	Screw		16	SM9/64(40)×8
H52	H2000I2160	Nut	1	1	



# I. OIL LUBRICATION MECHANISM

---

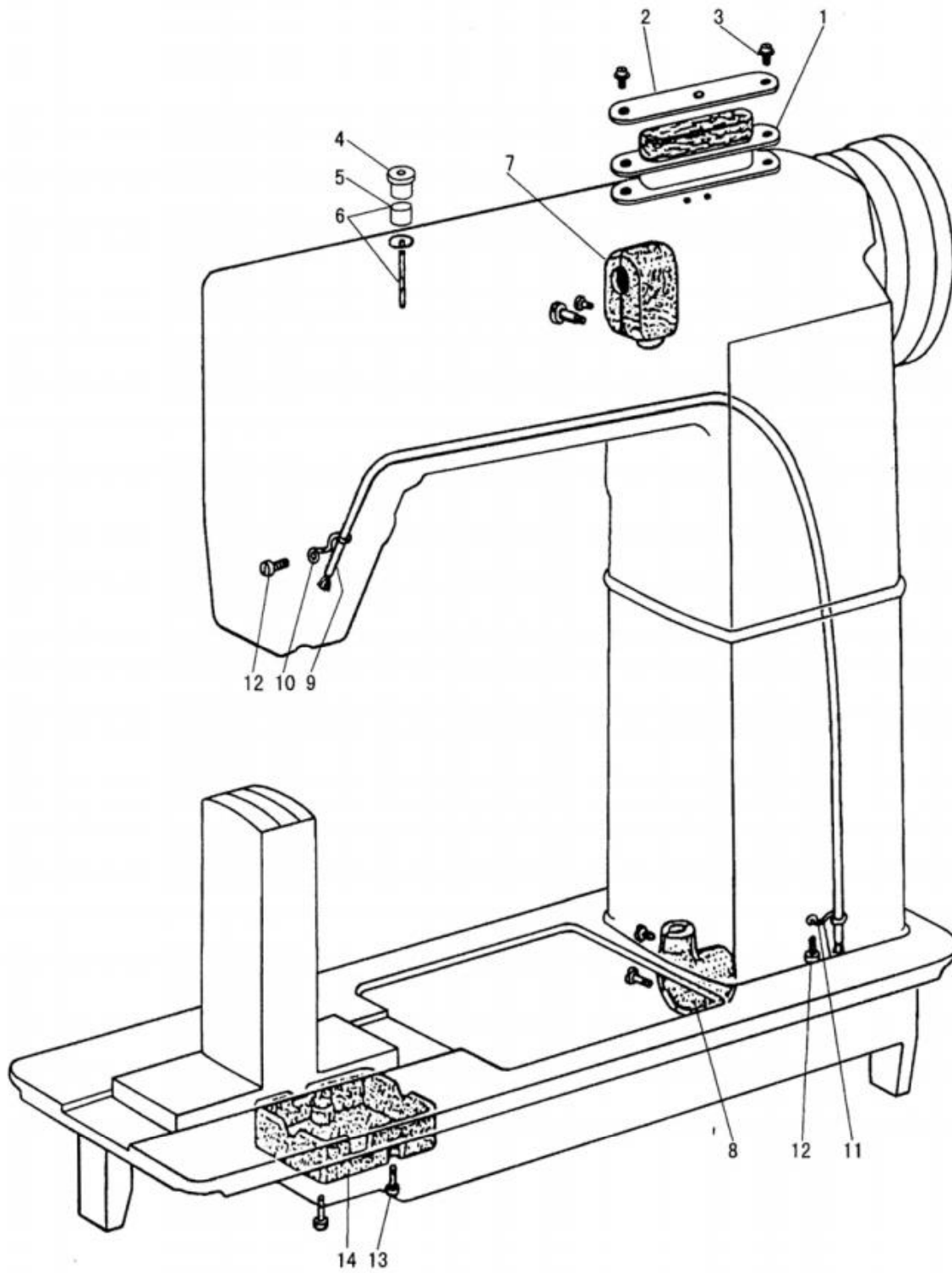

## I.OIL LUBRICATION MECHANISM

Fig. No.	Part No.	Description	GC24018	GC24018-1	Remarks
I01	H2000M0170	Oil box (complete)	1		
I02	H2020M0065	Oil cover	1		
I03	HA300B2170	Screw	2		SM11/64(40)×9
I04	H2400J2010	Oil cap	1		
I05	H2400J2020	Felt	1		
I06	H2400J2030	Oil wick	1		
I07	H2407J0065	Gear box upper (complete)	1		
I08	H2408J0066	Gear box lower (complete)	1		
I09	H2410J0067	Pipe (complete)	1		
I10	H2400J2090	Holder	1		
I11	H2400J2080	Holder	1		
I12	HA100C2190	Screw	2		SM11/64(40)×8
I13	HA7311C606	Screw	2		SM11/64(40)×15
I14	H2400J2060	Gear box	1		

# J. ACCESSORIES

---

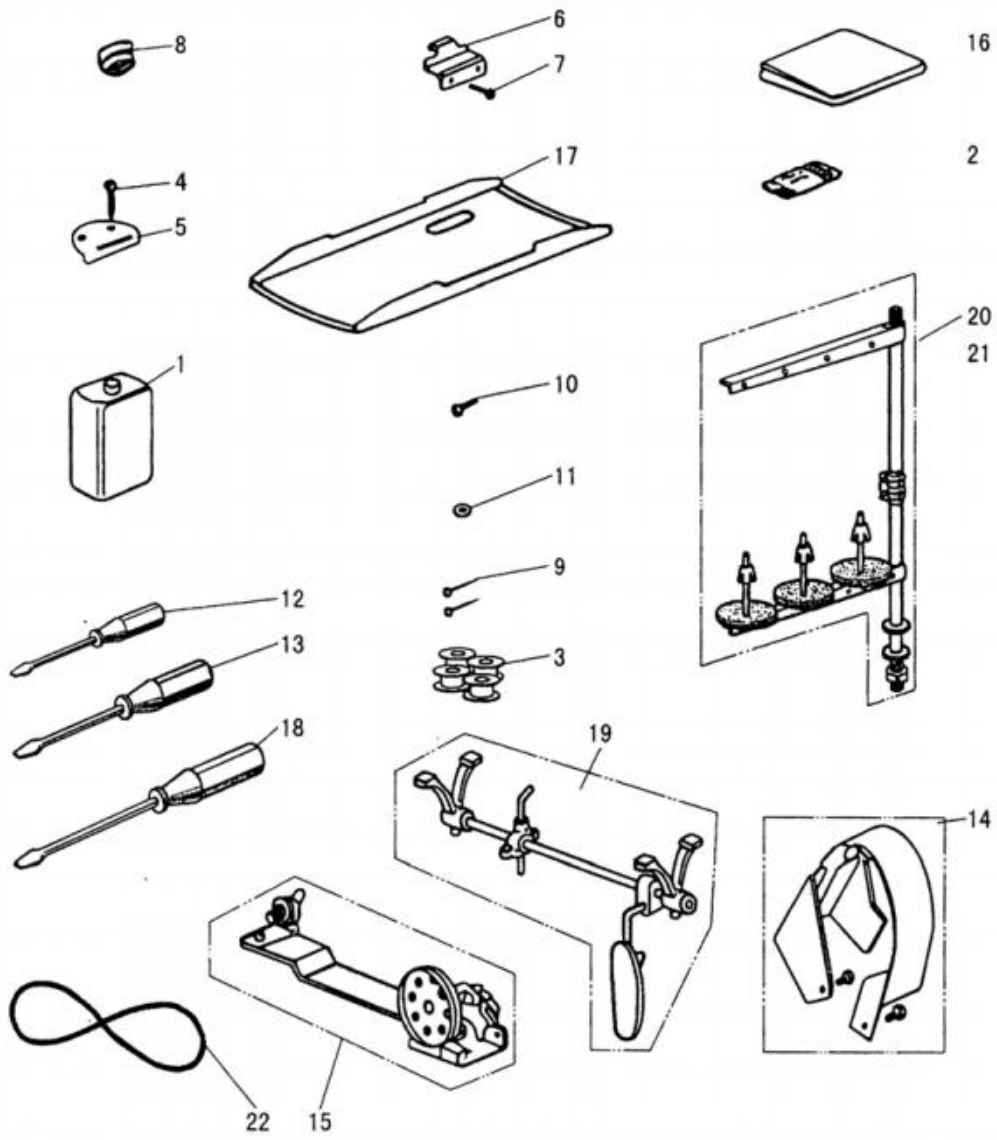

## J.ACCESSORIES

Fig. No.	Part No.	Description	GC24018	GC24018-1	Remarks
J01	H2004O0069	Oiler	1	1	P831001X02
J02	H2404D0653	Needle	4	6	DP×5-16
J03	H2400I2020	Bobbin	3	4	
J04	H802060250	Screw	4	4	GB/T100 6×25
J05	H2404K0654	Hinge(1)	2	2	
J06	H2404K0655	Hinge(2)	2	2	
J07	H2404K0656	Screw	4	4	SM15/64(28)×9
J08	H2404K0657	Vibration preventing rubbers	4	4	
J09	HZB1020250	Nail	10	10	YB/T5002 2×25
J10	H801045200	Screw	2	2	GB/T99 4.5×20
J11	HA300J2230	Washer	2	2	
J12	HA300J2210	Screw driver(small)	1	1	
J13	HA300J2200	Screw driver(middle)	1	1	
J14	H2405K0066	Belt cover (complete)	1	1	
J15	HA109J0068	Bobbin winder (complete)	1	1	
J16	HA100J2180	Vinyl cover	1	1	
J17	H2400K0050	Oil reservoir	1	1	
J18	HA300J2070	Screw driver(large)	1	1	
J19	H2400K0070	Knee lifter (complete)	1	1	
J20	HA200J2030	Cotton stand	1		GC24018
J21	H3200L0120	Cotton stand		1	GC24018-1
J22	H2400K0080	Belt	1	1	M55 (1397mm)

**SHANGHAI BIAOZHUN HAILING SEWING MACHINERY CO., LTD.**

**ADD: NO.850 Shulin Road, Songjiang District Shanghai, P.R.China**

**Zip Code: 201612**

**Overseas Business: TEL: 86-21-64853303 FAX: 86-21-64854304**

**E-mail:sales@highlead.com.cn      <http://www.highlead.com.cn>**

The description covered in this manual is subject to change for improvement of the commodity without notice

2016.7. Printed