

**HIGHLEAD**

**GC20818-MD**

**Basting Machine**

**Instruction Manual**  
**Parts Catalog**

---

## ■ CAUTIONS ON USE

### 1. Cautions on operation

1) When the power is turned on and off, keep your foot away from the pedal. Note that the needle goes up to the UP position when the power switch is turned on.

2) Note that braking does not work if the power is turned off, or power failure takes place, during machine operation.

3) Since dust or other foreign matter entering into the control box may cause malfunction or trouble, be sure to keep control box cover closed during operation.

4) Do not use a multimeter to check the control circuit. Otherwise, semiconductors in the control circuit might be damaged by voltage from the multimeter.

### 2. Precautions before starting operation:

1) Never operate the machine before filling the machine's oil pan.

2) When a new sewing machine is first turned on, verify the rotational direction of the pulley with the power on.

3) Verify the voltage and phase (single or three) with those given on the machine nameplate.

### 3. Precautions for operating conditions:

1) Avoid using the machine at abnormally high temperatures (35°C or higher) or low temperatures (5°C or lower) .

2) Avoid using the machine in dusty conditions.

### 4. Connection of control box

The control box should be connected as shown to the right.

Note: (1) Be sure to turn the power switch off for safety before connecting or disconnecting the connectors.

(2) The combination of the machine heads with the motor control panels are specified below. Use special care for the correct combination when replacing the machine head or motor control panel.

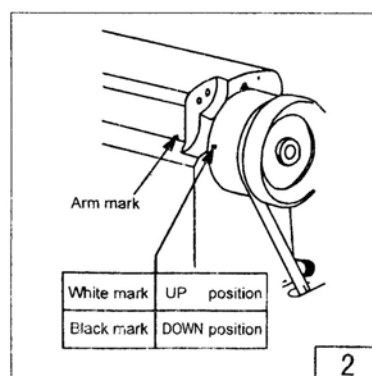
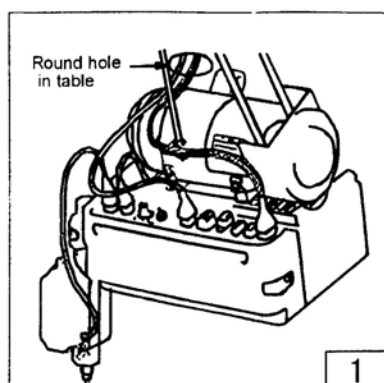

### 5. Adjustment of needle bar stop position

1) Adjust of "UP" position: When the pedal is kicked down by heel, the machine stops at "UP" position.

---

If the marks deviate larger than 3 mm, adjust as follows.

- (1) Disconnect the plug (12 pins) of cable from the machine head.
- (2) Run the machine and stop at "UP" position.
- (3) While holding the pulley, insert the "adjusting tool" in the hole "A", then remove the tool.

2) Adjust of "Down" position: When the pedal is "Neutral" the machine stops at "Down" position. If the marks deviate large than 5 mm, adjust as follows.

- (1) Disconnect the plug (12 pins) of cable from the machine head.
- (2) Run the machine and stop at "Down" position.
- (3) While holding the pulley, insert the "adjusting tool" in the hole "B", then remove the tool.

3) Confirm the stop operation, then set the plug (12 pins) coming from the machine head into the receptacle.

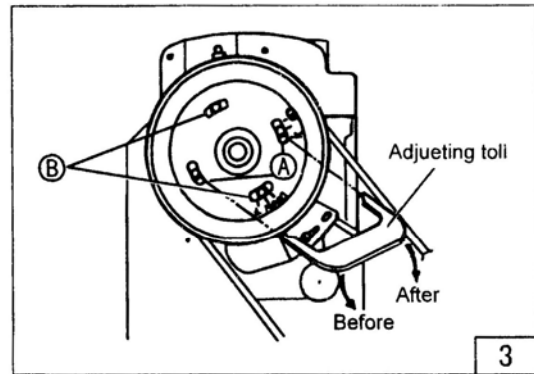

## ■ CAUTIONS ON USE:

### 1、 Lubrication(1)(Fig.4)

Pour oil up to position "H" of the oil tank.

During operation, check the oil level periodically, and in cases where the oil level is below position "L", replenish the oil supply up to position "H".

Use white spindle oil.

### 2. Lubrication (2)(Fig.5)

When a new sewing machine is used for the first time, or sewing machine left out of use for a long time is used again, replenish a suitable amount of oil to the portions indicated by arrow in the fig.

**Note: Lubricate the Hook Base everyday.**

○ 1-2 drops

● 3-4 drops

### 3、 Adjustment of oiling to rotating hook( Fig.6 )

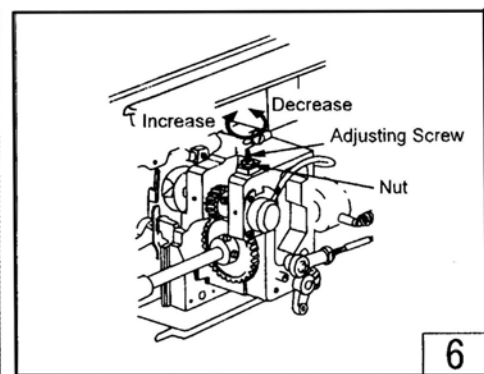
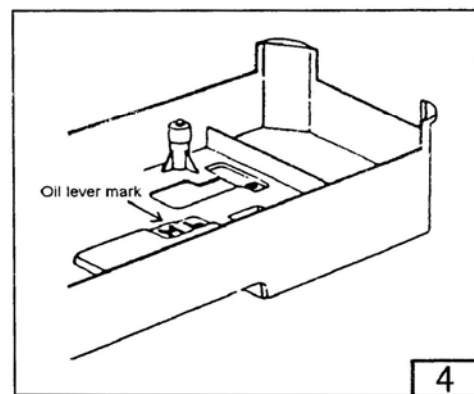
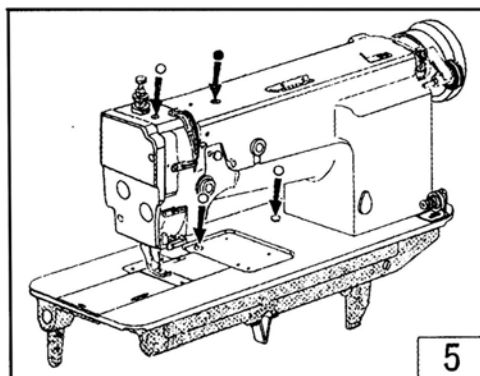

## ■ OPERATION

### 1、Attaching the needle(Fig.7)

- 1 ) For needle, use "Mt×190"
- 2 ) Determine the needle gauge for thickness of thread used.
- 3 ) Loosen the needle clamp screw.
- 4 ) Hold the needle with the prime groove turned to the front and put it into the needle socket until it stops.
- 5 ) Tighten the needle clamp screw.

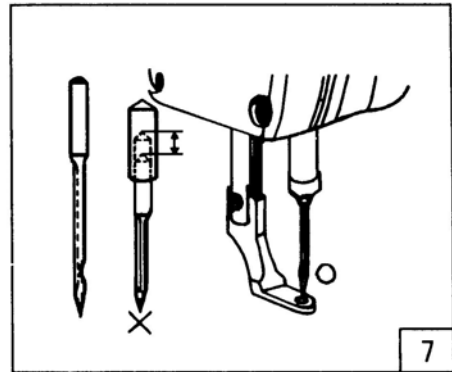

### 2、Winding the bobbin thread(Fig.8)

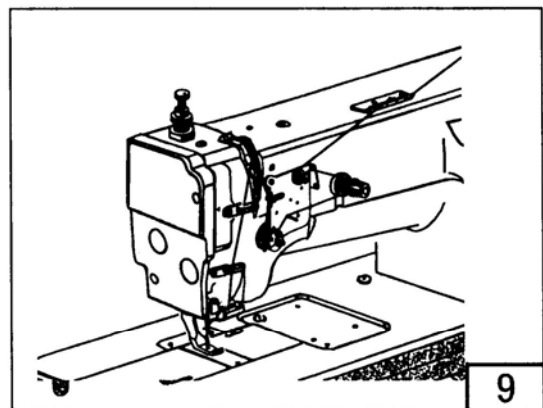
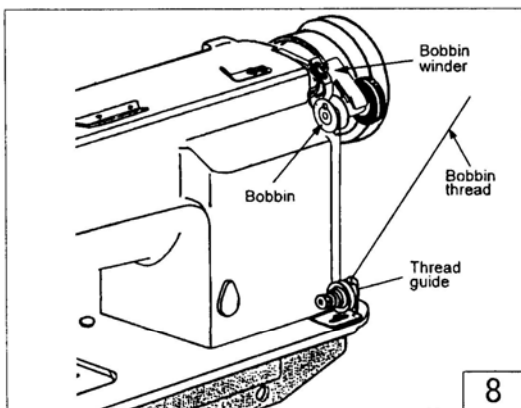

### 3、Threading the machine(Fig.9)

The needle should be threaded in the order numbered in the right figure.

### 4、Setting of bobbin(Fig.10)

1 ) Put the bobbin into the bobbin case in the direction that the bobbin in the bobbin case rotates clockwise, viewed from the front, when the thread is pulled.

2 ) Pass the thread through slit ① of bobbin case and pull. The thread will be led out from aperture ②.

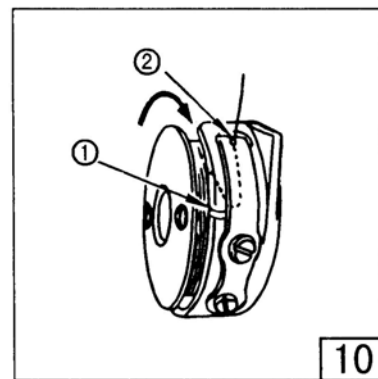

**\*The bobbin should rotate in the direction shown by arrow in the figure when the thread is pulled.**

### 5、Leading out the bobbin thread(Fig. 11)

1 ) Put the bobbin and bobbin case together into the hook, as shown in the right figure.

2 ) Pick up the end of needle thread by left hand and lightly press down the pedal by toe to run the machine one turn. When the needle thread is pulled up, the bobbin thread will be drawn out as shown in the right figure.

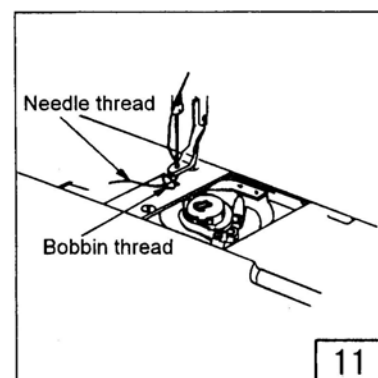

## 6、 Thread tension (Fig.12)

## 7、 Bobbin thread tension adjustment( Fig.13)

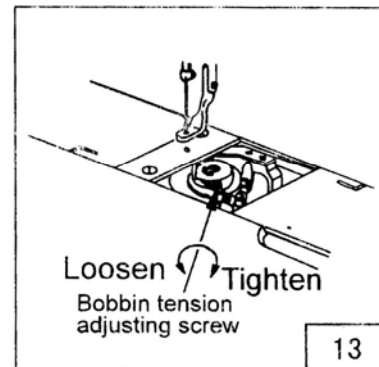
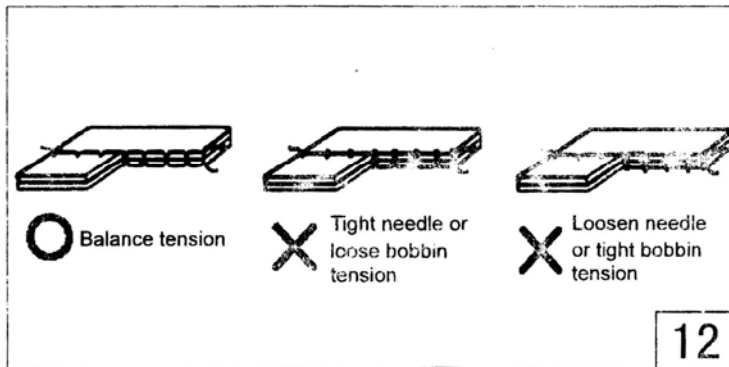

## 8、 Needle thread tension adjustment

The needle thread tension can be adjusted by changing pressure of the tension disk, and force and stroke of the thread take-up spring.

### 1) Tension disk pressure adjustment (Fig.14)

(1) In most cases, thread tension can be properly adjusted only by changing tightness of the tension regulator thumb nut.

(2) To increase pressure, turn the nut clockwise.

(3) To decrease pressure, turn the nut counter-clockwise.

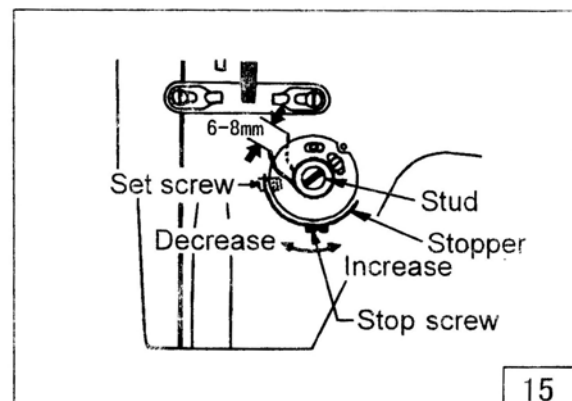
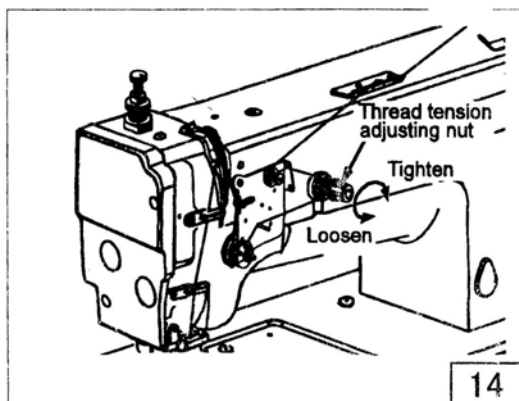

### 2) Thread take-up spring force/stroke adjustment (Fig.15)

Apply a screwdriver to the thread take-up spring stud and turn the stud. Spring force increases when the screwdriver is turned counter-clockwise, and decreases when turned clockwise. If the stud is tight, remove the face plate and loosen the screw of tension regulator slightly.

### 3) Thread take-up spring force/stroke adjustment (Fig.15)

Loosen the stop screw, adjusting the stopper block. After the adjustment, be sure to tighten the set screw. The standard stroke of thread take-up spring is from 6mm to 8mm.

## 9、 Adjustment of thread tension regulator (Fig. 16)

1) Adjustment of thread tension regulator setting position. The standard gap is about 0.5mm when the tension release cam salience is in contact with the tension release pin. To adjust, loosen screw A and change position of the thread tension regulator properly.

2) Tension release timing adjustment. The tension release cam should be set so that the tension release disks come to close at the time the needle plunges into the throat plate.

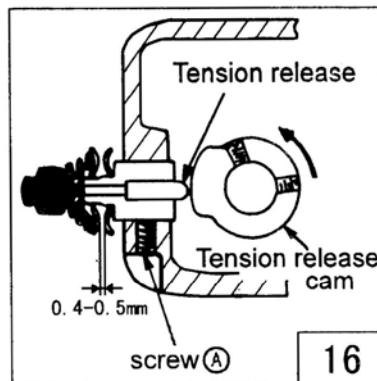

## 10、 Presser foot pressure adjustment (picture 17)

Loosen the pressure adjusting screw lock nut and turn the pressure adjusting screw ③. Turn the screw clockwise to increase the pressure. Turn the screw counter-clockwise to decrease the pressure.

**Note: Do not change setting of screw ④. If the screw is too tight, clapping noise may occur during operation.**

## 11、 Adjustment of presser foot height (picture 17)

### 1) Height of presser foot

The standard height of the presser foot at its lowest position is 1.0 mm measured between the presser foot bottom surface and the throat plate top surface (see the detail of part "A").

To adjust the height of the presser foot, loosen the set screw ② used to secure the presser bar guide bracket and vertically move the presser bar.

### 2) Stroke of presser foot

loosen screw ① and adjust position of presser bar lifting bracket so that the presser foot starts going up when the needle point reaches 0.5mm-1.0mm above the presser foot bottom surface. (When this adjustment is made, the height of the presser foot at stop of the machine is about 26.5mm over the throat plate.)

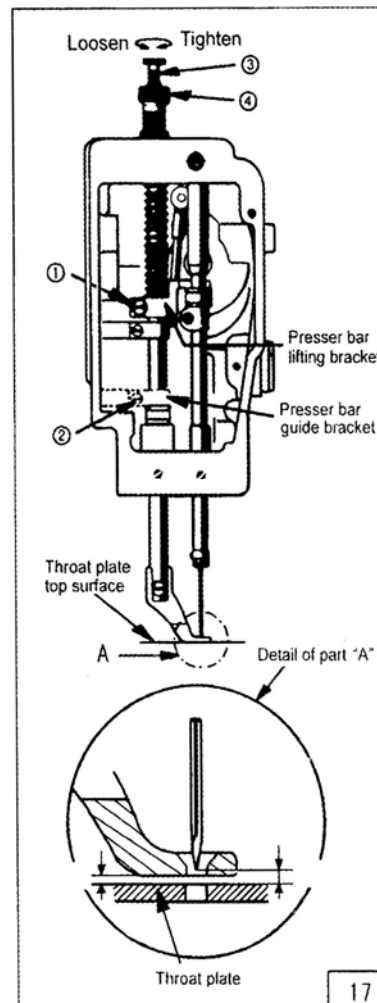

## 12、 Timing of hook and needle(Fig.18)

1) When the needle is at 2.2mm above its lowest position, the hook and the needle should be located as described below.

- The upper edge of needle eye is 1.3mm below the hook tip.
- The clearance between the hook tip and the needle side surface is 0.05mm.

2) The relative positions of the hook and the needle can be adjusted as described below.

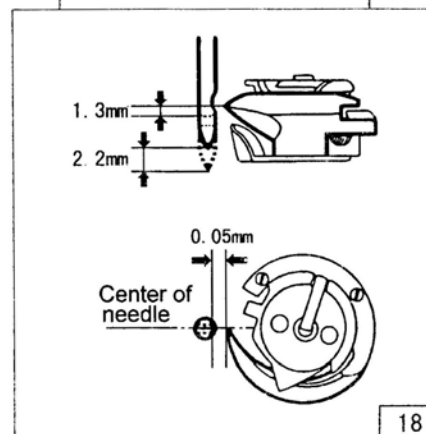

\*The adjustment is easier when the presser foot and the throat plate are previously removed.

▪ **Adjustment of hook tip position (Fig.19)**

a、 Lean outward the machine head. Loosen three hook shaft gear screws.

b、 Rotate the balance wheel by hand to position the needle to 2.2mm above the needle DOWN position.

c、 Rotate the hook by hand to align the hook tip with the center of the needle.

d、 Adjust the lateral position of the hook saddle so that the clearance between the hook tip and the needle side surface is 0.05mm.

To adjust, loosen screws ①, ② and ③.

**Note: Use care not to loosen set screw ③ excessively, and not to disengage the hook shaft gear (small) from the gear (large).**

e、 Tighten the loosened screws in the following order:

- 3) Lightly press the gear (large) against the side wall of hook saddle and tighten set screw ③ first.
- 4) Check the clearance between the needle and the hook and then tighten screw ①.
- 5) Finally tighten screw ②.

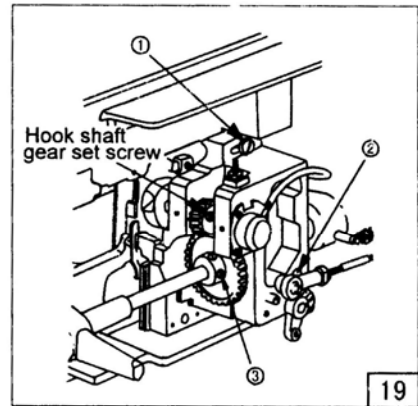

**13、 Timing between hook motion and take-up lever motion(Fig.20)**

When the toothed belt is removed for replacement, the timing between the hook motion and the take-up lever motion should be adjusted as follow:

1 ) Turn the balance wheel by land to locate the take-up lever to its highest position.

2 ) Lean outward the machine head to make sure the arrow mark (timing mark) on the toothed belt pulley meets the black line put on the bearing bracket.

3 ) If the arrow mark is not in line with the black line, remove the toothed belt and install again so that the two marks are in line, as shown in the right figure.

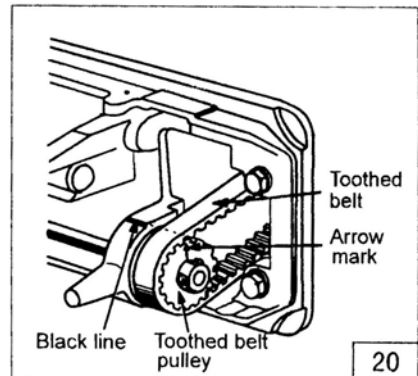

**14、 Timing between hook motion and opener motion(Fig.21)**

1 ) Rotate the balance wheel by hand to locate the opener holder to the farthest position away from the throat plate.

2 ) Make sure the clearance between the portion ① of bobbin case and the opener is about 0.2mm as shown in the right figure.

3 ) If the clearance is too large or small, loosen opener screw ② and adjust position of the opener.

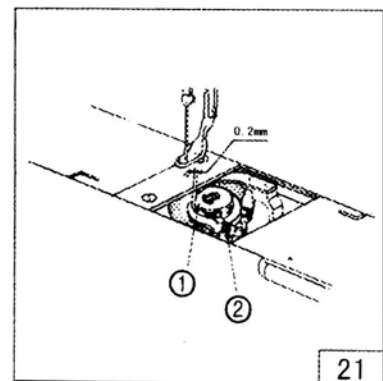

## ■ ADJUSTMENT OF THREAD TRIMMER

### 1、 Installation of movable knife (Fig.22)

1) Initial position of movable knife

a、 Rotate the balance wheel to lower the needle to the DOWN position

b、 While keeping the DOWN position, press the cam follower crank to enter the roller into the trimmer cam groove.

c、 Rotate the balance wheel until the black mark point on the arm meets the white mark point on the balance wheel. In so doing, care should be taken not to allow the cam roller to leave the cam groove

(use a screwdriver, or any other suitable tool).

d、 Loosen bolt ① of the rocker arm

e、 Adjust the movable knife so that its tip protrudes by 3-3.5mm from the fixed knife blade edge, as shown below.

After the adjustment, tighten bolt ①.

2) Clearance between the movable trimmer knife and the hook (Fig.23)

a、 Rotate the balance wheel to lower the needle to the DOWN position

b、 While keeping the DOWN position, press the cam follower and turn the balance wheel by hand in the farthest position.

c、 Rotate the hook by hand in the directions shown by arrows in the right and adjust the clearance between the movable knife and the hook to about 0.2mm(loosen screws ① and ② to adjust).

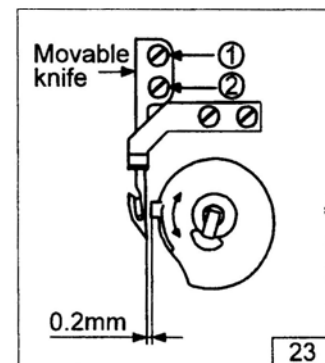
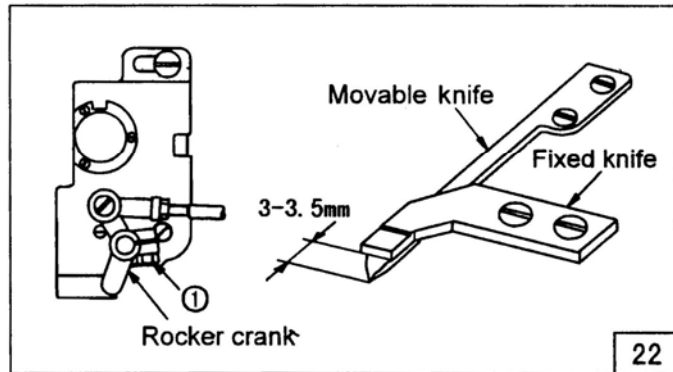

### 2、 Adjustment of trimmer cam (Fig.24)

1) Rotate the balance wheel to lower the needle to the DOWN position

2) While keeping the DOWN position, press the cam follower crank to enter the roller into the trimmer cam groove.

3) Adjust the trimmer cam so that the movable knife starts moving when the balance wheel is turned by hand and the green mark point on the balance wheel meets the black point on the arm.

To adjust, loosen two trimmer cam screws A.

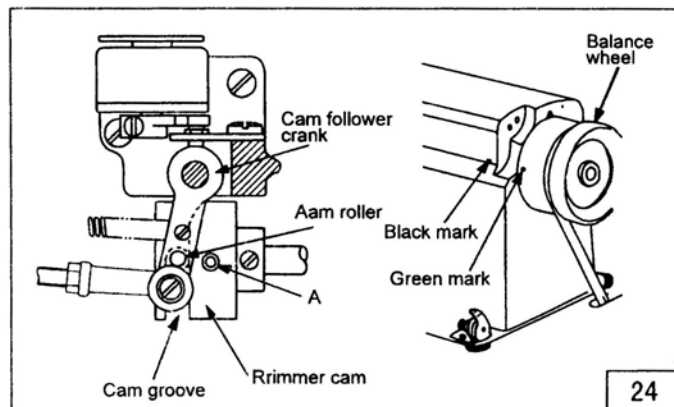



---

### 3. Adjustment of scissoring pressure of thread trimmer (Fig.25)

(1) Loosen bolt A used to secure the fixed knife base.

(2) Turn fixed knife vertical position adjusting screw B to adjust the scissoring pressure. After the adjustment, tighten bolt A.

**Note: The pressure should be adjusted as minimum as possible. Excessive pressure causes over-torque to the trimmer mechanism, and trimming failure.**

(3) Move the movable trimmer knife to make sure threads are cut successfully.

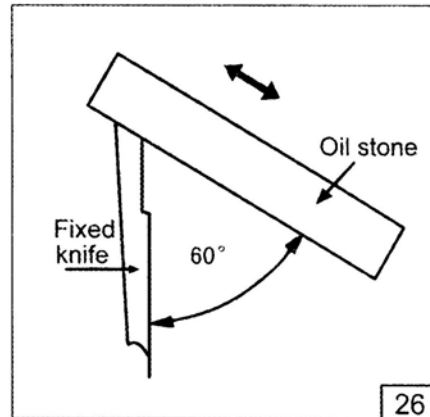
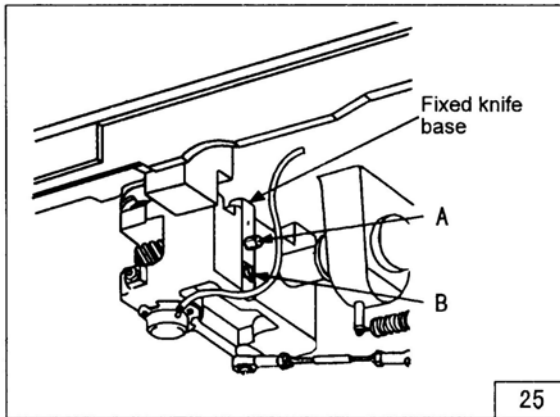

### 4. Sharpening the fixed knife(Fig.26)

If the fixed knife becomes dull, sharpen it as shown in the figure below.

Since it is impossible to sharpen the movable knife, replacement with a new one is required when the movable knife becomes dull.

# A. ARM BED AND ITS ACCESSORIES

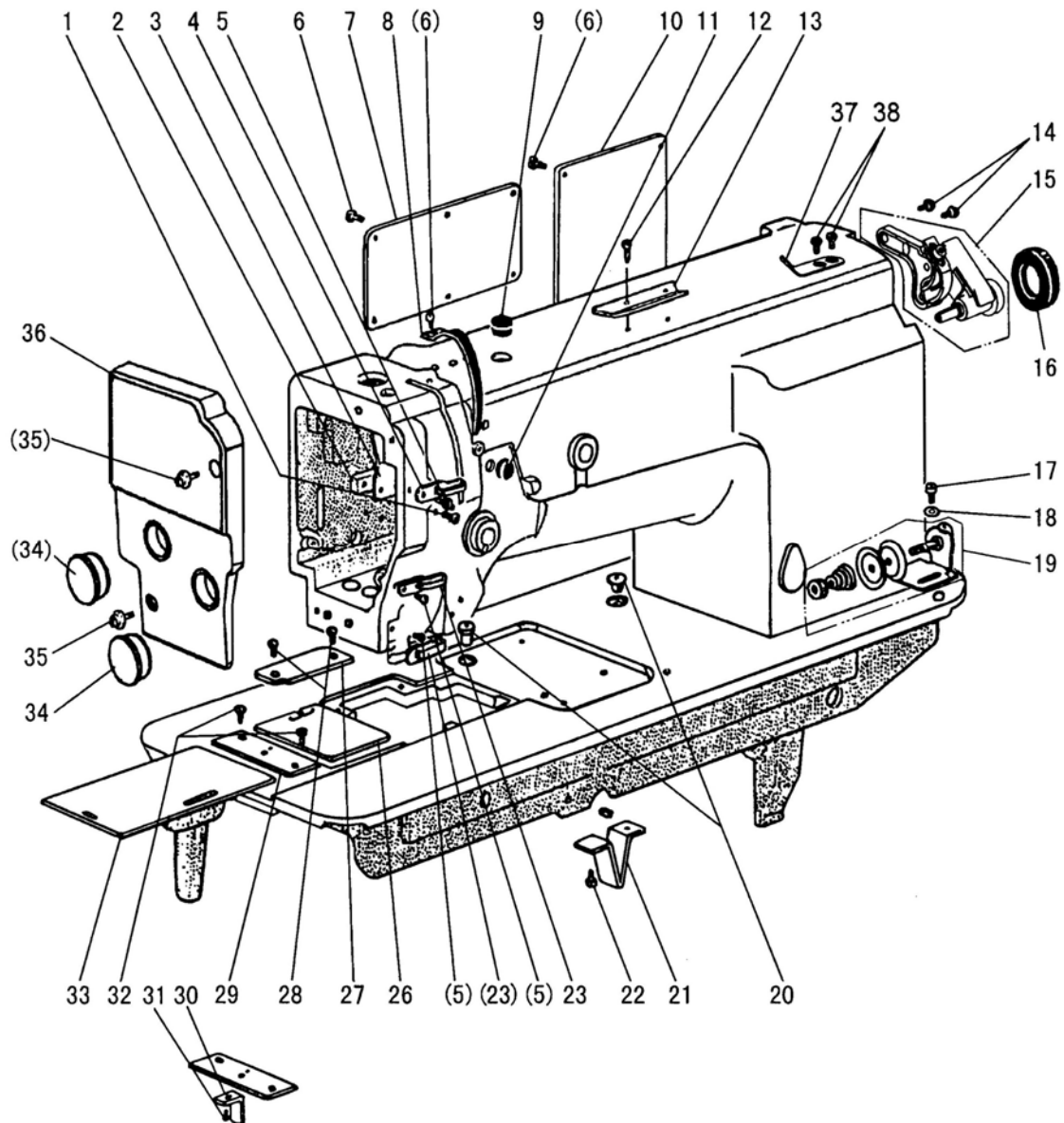

## A.ARM BED AND ITS ACCESSORIES

Fig. No.	Part No.	Description	Pcs.	Remarks
A01	H3000D2160	Screw	2	
A02	H2400B2060	Spacer	1	
A03	H3200B2060	Oil guide plate	1	
A04	H3200B2070	Thread guide	1	
A05	H2400B2080	Screw	3	
A06	HA300B2170	Screw	11	
A07	H3200B2030	Arm side cover (left)	1	
A08	H3200B2050	Thread take-up cover	1	
A09	H2400J2010	Oil cap	1	(Φ13)
A10	H3200B2040	Arm side cover (right)	1	
A11	H2000B2010	Rubber plug	1	(Φ13)
A12	HA700B2060	Screw	2	
A13	H2400B2100	Thread guide	1	
A14	HA100E2150	Screw	2	SM11/64(40)×10
A15	HH415B7101	Bobbin winder complete	1	
A16	H6658B8001	Rubber ring	1	Φ35
A17	HA100E2150	Screw	1	SM11/64 (40) ×10
A18	HA100B2070	Washer	1	Φ4.5×Φ8×1
A19	HH427B7101	Thread guide complete	1	
A20	H2000M0090	Cap	2	
A21	H4913B8001	Needle bar supporter	1	
A22	H4912B8001	Screw	2	
A23	H3200B2080	Thread guide	2	
A26	H4813B8001	Slide plate (left)	1	3/32-5/8
A27	H5015B8001	Cover	1	
A28	H4914B8001	Screw	2	
A29	HH411B8001	Needle plate	1	
A30	HH412B8001	Needle holder	1	
A31	HH413B8001	Screw	1	
A32	HA300B2190	Screw	2	SM11/64(40)×6.5
A33	H4747B8001	Slide plate (right)	1	3/32-1/4
A34	HA106B0673	Rubber plug	2	(Φ19)
A35	HA300B2160	Screw	2	
A36	H3200B2020	Face plate	1	
A37	H6756B8001	Thread cutter	1	
A38	H6762B8001	Screw	2	SM9/64(40)×4.5

B. THREAD TENSION MECHANISM

---

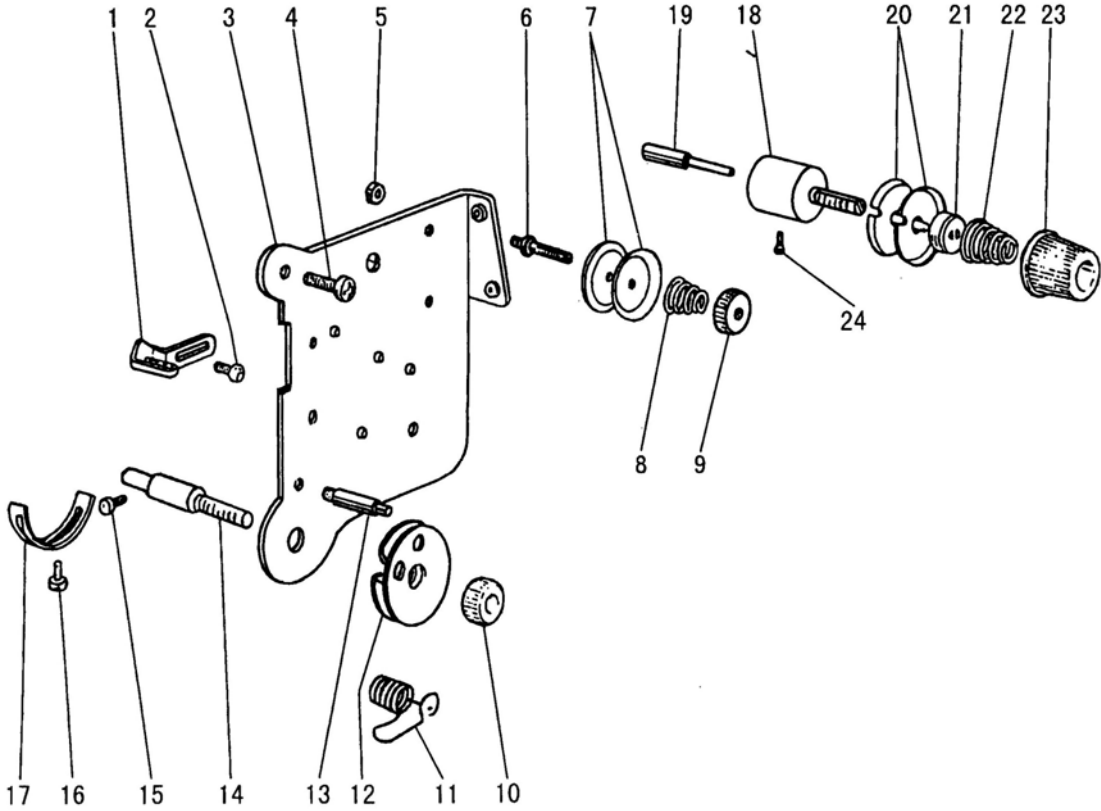

## B.THREAD TENSION MECHANISM

Fig. No.	Part No.	Description	Pcs.	Remarks
B01	H3221B0687	Thread guide	1	
B02	HA106B0676	Screw	1	SM9/64(40)×6
B03	H3221B6820	Mounting plate	1	
B04	HA300C2030	Screw	2	SM11/64(40)×8
B05	H3221B6810	Nut	2	SM11/64(40)×3
B06	H3221B0683	Thread tension stud	1	SM11/64(40)×14
B07	HA112B0693	Thread tension disc	2	
B08	H3221B0684	Spring	1	
B09	HA710B0671	Thumb nut	1	
B10	H2504C0658	Thumb nut	1	
B11	H32481B221	Thread Take-up spring	1	
B12	H32481BD21	Plate complete	1	
B13	H4804C8001	Screw	1	SM9/64(40)×22
B14	H2504C0652	Thread tension stud	1	
B15	H2004J0067	Screw	1	SM9/64(40)×7
B16	H3200B2100	Screw	1	SM9/64(40)×6.5
B17	H3221B6819	Stopper	1	
B18	HH406C8001	Thread tension stud	1	
B19	HH407C8001	Thread releasing pin	1	
B20	HA310B0705	Thread tension disc	2	
B21	HA310B0702	Tension releasing plate	1	
B22	HA607B0068	Spring	1	
B23	HA310B0701	Thumb nut	1	
B24	HA3411D308	Screw	1	

### C. THREAD TAKE-UP LEVER MECHANISM & ARM SHAFT MECHANISM

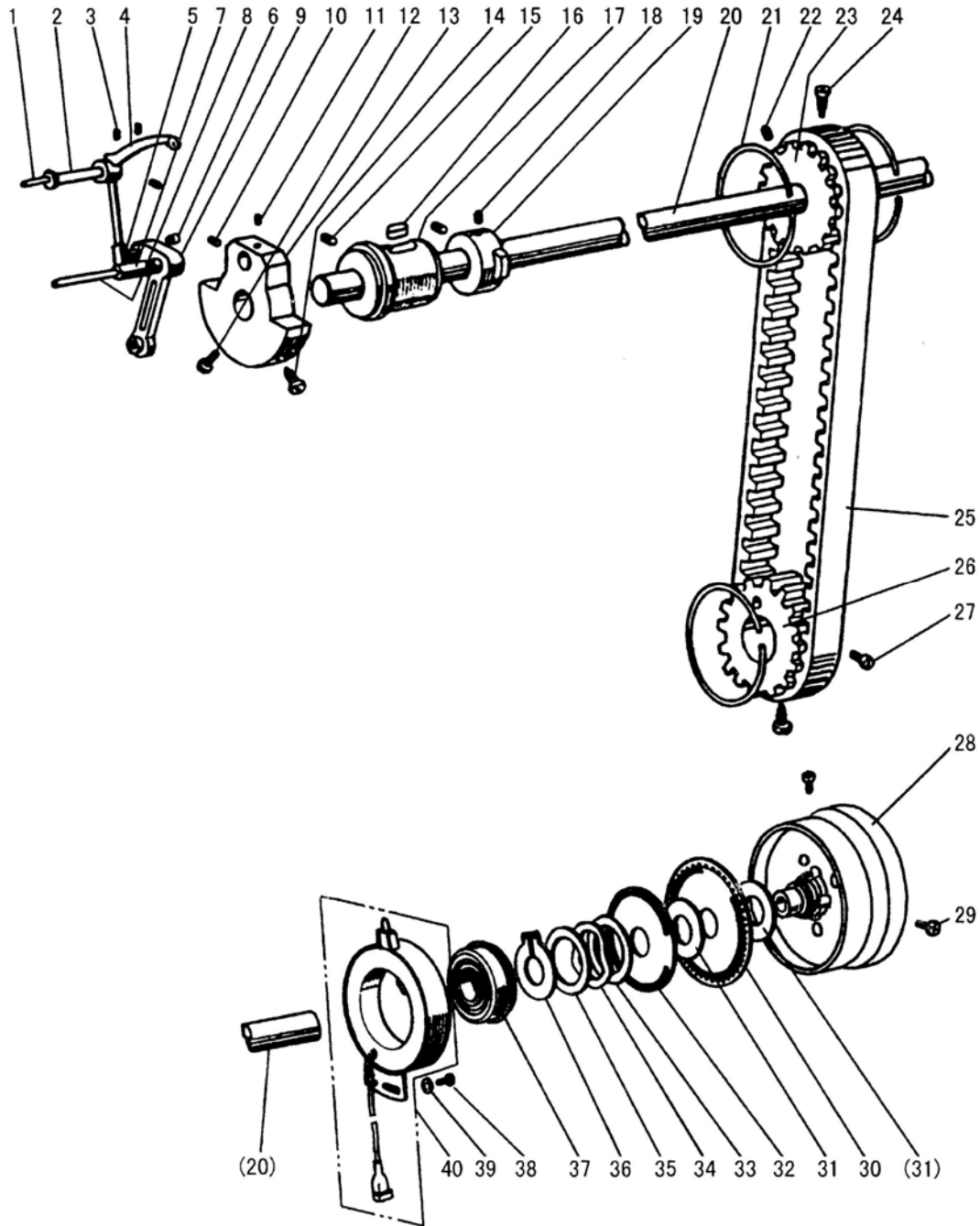

## C.THREAD TAKE-UP MECHANISM & ARM SHAFT MECHANISM

Fig. No.	Part No.	Description	Pcs.	Remarks
C01	H2405D1122	Oil wick	1	2.5×240
C02	H32422C108	Thread Take-up guide bracket pin	1	
C03	HA110D0672	Screw	3	SM15/64(28)×12
C04	H2405D1111	Thread Take-up lever	1	
C05	H2405D1112	Thread Take-up slide block	1	
C06	H24211D305	Plug	1	
C07	H2405D0662	Thread take-up crank pin	1	
C08	H2405D0662	Oil wick	1	
C09	H32111D704	Needle bar connecting link	1	
C10	HA307C0662	Screw	1	SM1/4(40)×6
C11	HA105D0662	Screw	1	SM1/4(40)×4
C12	HA100C2070	Screw	1	SM9/32(28)×10
C14	HA100C2060	Screw	1	SM9/32(28)×13
C15	H2405D0664	Screw	1	SM15/64(28)×14
C16	H32111B104	Felt	1	
C17	H3204B0011	Arm shaft bushing left (complete)	1	
C18	HA305E0662	Screw	2	
C19	HH404D8001	Thread releasing cam	1	
C20	H3204C0651	Arm shaft	1	
C21	H3205C0661	Spring flange	3	
C22	HA113F0684	Screw	1	SM15/64(28)×8.5
C23	H3207C0671	Pulley	1	
C24	HA100F2130	Screw	1	SM15/64(28)×6.7
C25	H3200C2030	Cog belt	1	
C26	H3205C1021	Pulley	1	
C27	HA104F0654	Screw	2	
C28	H4931L8001	Machine pulley	1	
C29	HA110D0672	Screw	2	
C30	H4930L8001	Speed command disk F11 (down)	1	
C31	HA700R0030	Spacer A	2	
C32	H4928L8001	Speed command disk F20 (up)	1	
C33	HA700R0040	Spacer B	1	
C34	HA700R0050	Spacer	1	
C35	HA700R0060	Stopper	1	
C36	H007009300	Retaining ring C-type	1	
C37	H3205J0662	Ball bearing	1	
C38	HA300C2030	Screw	1	
C39	HA703R0067	Washer	1	
C40	HA703R0065	Detector bracket	1	

# D. NEEDLE BAR & PRESSER FOOT MECHANISM

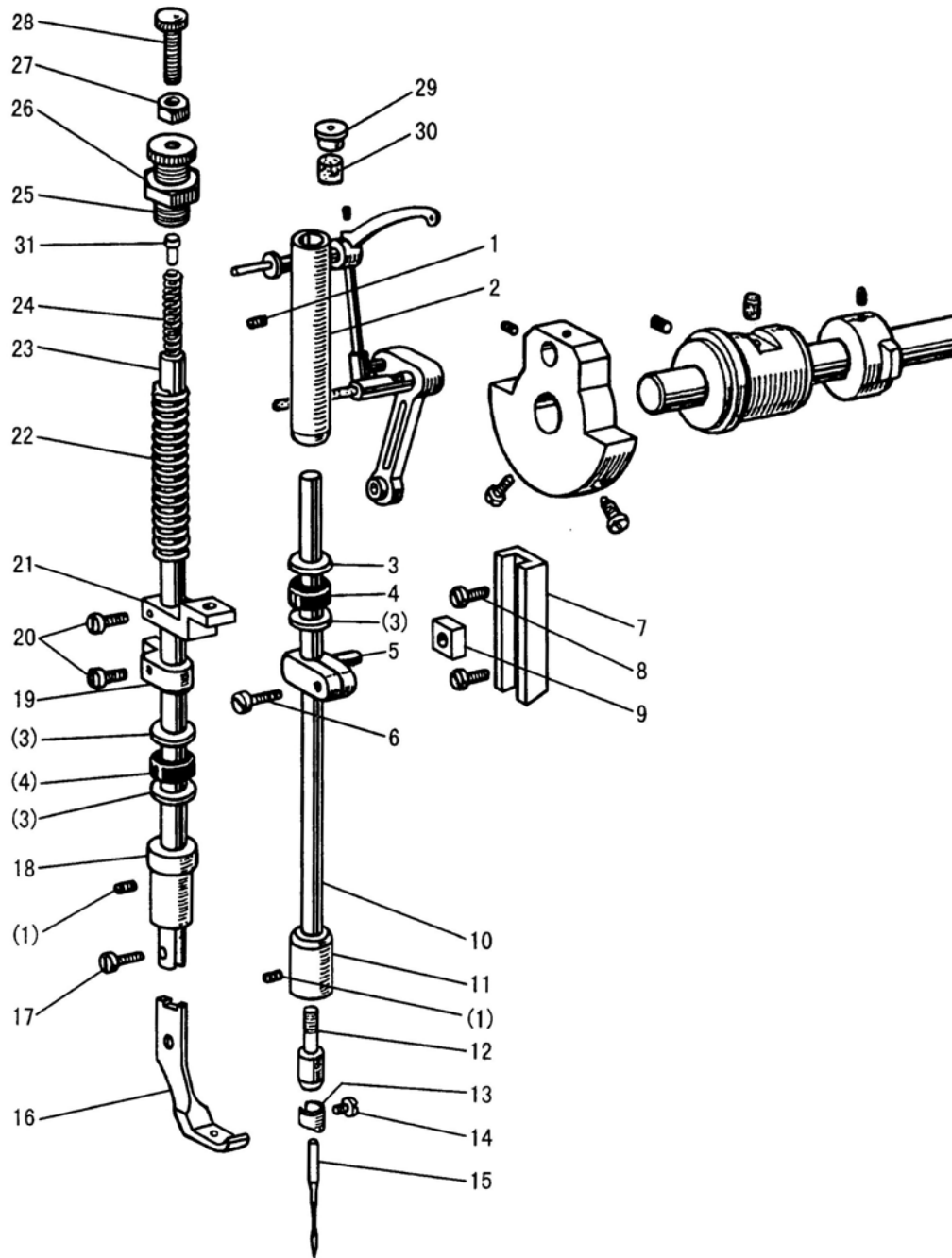



## D.NEEDLE BAR & PRESSER FOOT MECHANISM

Fig. No.	Part No.	Description	Pcs.	Remarks
D01	H2405D0664	Screw	3	SM15/64(28)×14
D02	HD417D8001	Bushing	1	
D03	HH405E8001	Washer	4	
D04	HH406E8001	Rubber ring	2	
D05	H32111D504	Needle bar connecting	1	
D06	H32111D604	Screw	1	SM9/64(40)×8.5
D07	HD415D8001	Crank guide	1	
D08	HA100C2190	Screw	2	SM11/64(40)×8
D09	HD416D8001	Bell crank guide	1	
D10	HH417E8001	Needle bar	1	
D11	HD413D8001	Bushing	1	
D12	H6204D8001	Needle clamp	1	
D13	HA500C2030	Needle bar thread guide	1	
D14	HA100C2170	Screw	1	SM1/8(44)×4.5
D15	HD404D0651	Needle	1	MT×190 16#
D16	HH407E8001	Lifting presser	1	
D17	H3200E2020	Screw	1	1/8(44)×9
D18	HH408E8001	Bushing	1	
D19	HH409E8001	Presser bar position guide bracket	1	
D20	HA300C2030	Screw	2	SM11/64(40)×8
D21	HH411E8001	Bracket	1	
D22	HH412E8001	Lever spring	1	
D23	HH413E8001	Presser bar	1	
D24	HH414E8001	Spring	1	
D25	HA117H0692	Nut	1	SM1/2×28
D26	H2400G0140	Screw	1	SM1/2(28)×55
D27	H2400G0160	Nut	1	SM11/64(40)
D28	H2400G0150	Screw	1	SM11/64(40)×48
D29	HA704O0657	Rubber plug	1	
D30	HE016L8001	Felt	1	
D31	HH416E8001	Pin	1	

# E. HOOK SADDLE MECHANISM

---

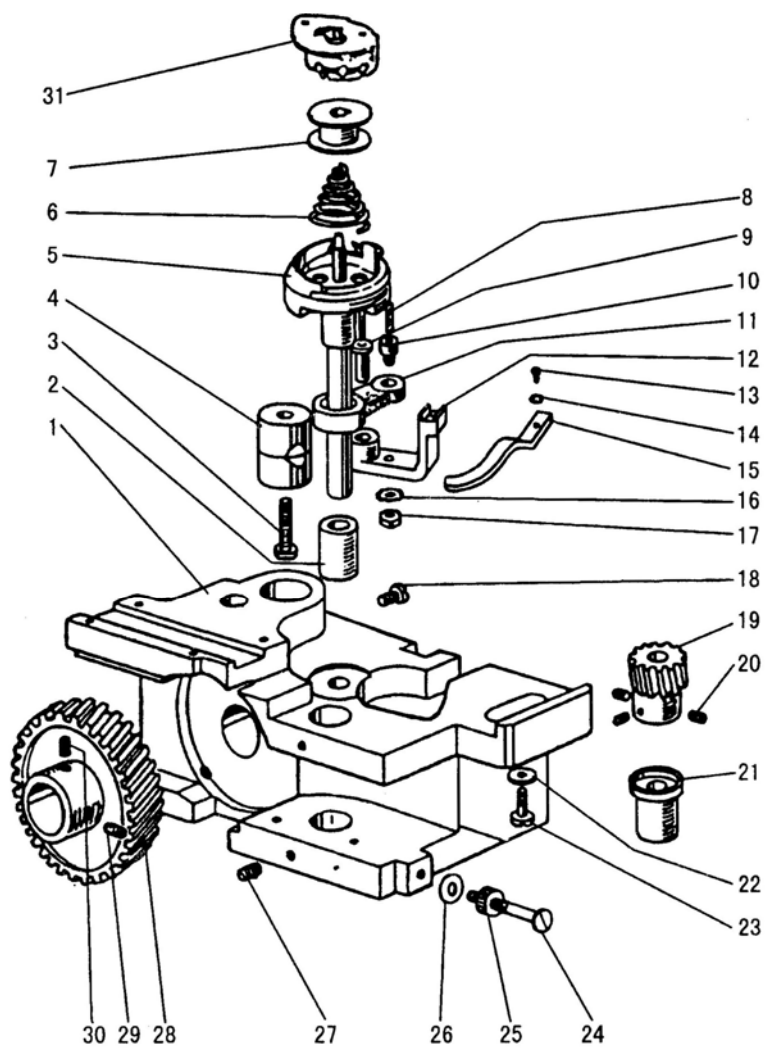

## E.HOOK SADDLE MECHANISM

Fig. No.	Part No.	Description	Pcs.	Remarks
E01	HH404F8001	Hook saddle (right)	1	
E02	H3204I0021	Hook shaft bushing (upper) complete	1	
E03	H3207I0661	Screw	1	SM15/64(28)×30
E04	H3207I0066	Bushing	1	
E05	H8504I7101	Hook complete	1	HSH-12-15M (3)
E06	H6906H8001	Spring	1	
E07	H8505I8001	Bobbin	1	B0-112(A)M
E08	H3204I0656	Oil wick	2	2.5×15
E09	H32153I504	Bobbin case opener holder pin	1	
E10	H32153I204	Screw	1	SM3/16 (30) ×7.8
E11	H32153I304	Ling	1	
E12	H32153I104	Bobbin case opener holder	1	
E13	H2004J0067	Screw	1	SM9/64 (40) ×7
E14	H3200I2030	Washer	1	
E15	H3200I2020	Opener	1	
E16	H005008050	Spring washer	1	GB/T93 5
E17	HA104G0658	Nut	1	
E18	H3204I0657	Screw	1	SM3/16(28)×14.5
E19	H32142I204	Gear (small)	1	
E20	HA105D0662	Screw	3	SM1/4 (40) ×4
E21	H3204I0653	Hook shaft bushing (lower)	1	
E22	H2013J0065	Washer	1	
E23	H3200I2050	Screw	1	SM1/4(24)×23
E24	H3204I0658	Screw	1	SM3/16×(28)×43
E25	H3204I0659	Nut	1	SM3/16(28)
E26	H005014050	Spring washer	1	GB/T955 5
E27	HA305E0662	Screw	2	SM15/64 (28) ×4.5
E28	H32142I104	Gear (large)	1	
E29	HA307C0662	Screw	1	SM1/4(40)×6
E30	H3204I6510	Screw	1	SM1/4(40)×6.5
E31	H8506I8001	Bobbin case	1	CP-12C

# F. KNIFE MECHANISM

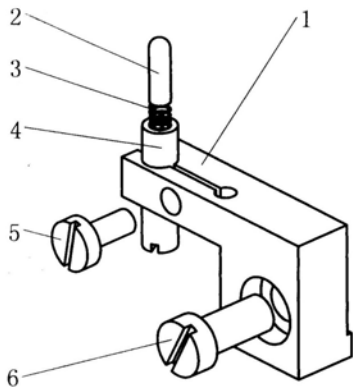
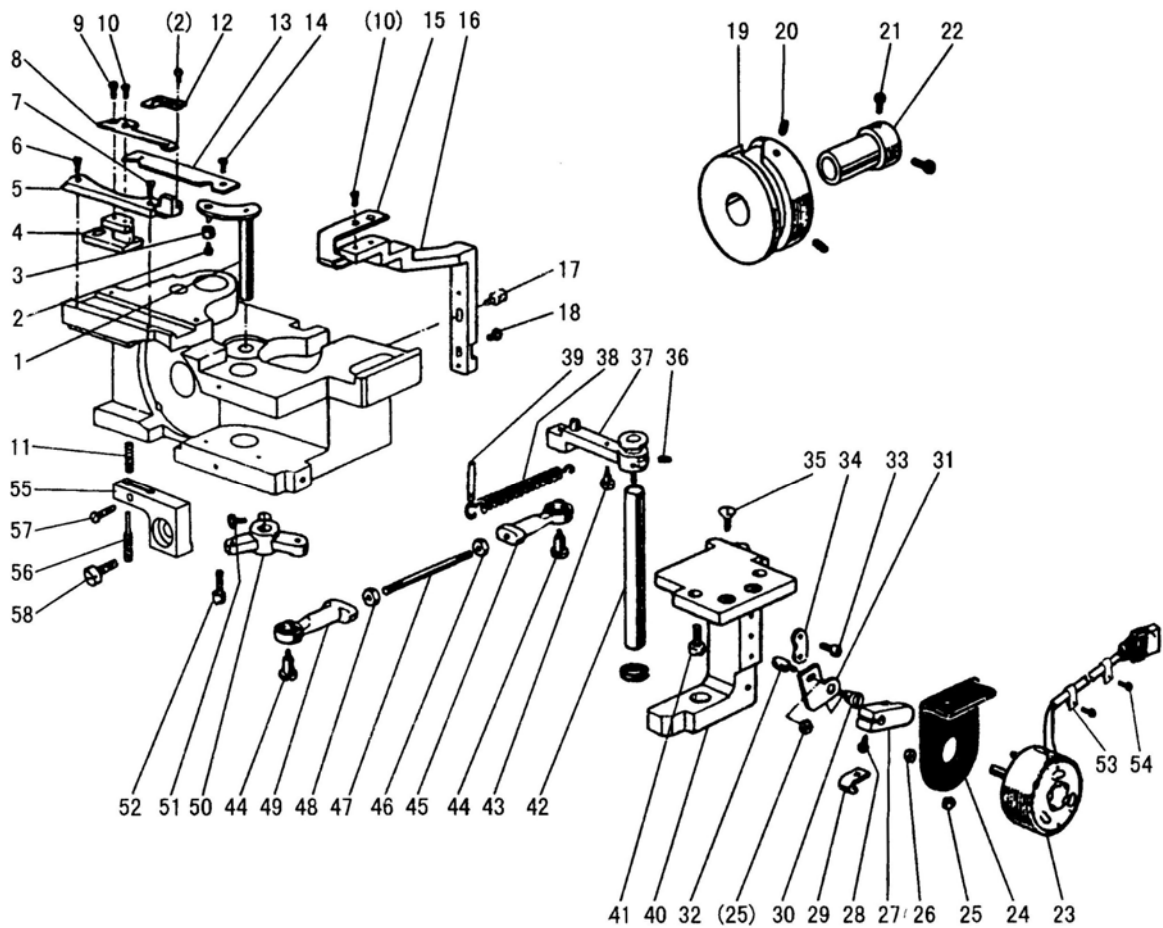

- 1. 54G06-002P01 Support Frame
- 2. 54G06-009P01 Support Pins
- 3. 34H2-007D1b1 Reversing Spring
- 4. 54G06-010P01 Screw
- 5. 22T4-015 Screw
- 6. 53H07-033P01 Screw

## F.KNIFE MECHANISM

Fig. No.	Part No.	Description	Pcs.	Remarks
F01	H4921J8001	Lever	1	
F02	H4915J8001	Screw	2	SM3/32 (56) ×3.8
F03	H4920J8001	Roller	1	
F04	H4924J8001	Knife pad (right)	1	
F05	H6904I8001	Guide (right)	1	
F06	H4925J8001	Screw	1	SM9/64 (40) ×9.5
F07	H4912J8001	Screw	1	SM1/8 (44) ×9.2
F08	HH408J8001	Move knife	1	
F09	H4913J8001	Screw	1	SM9/64 (40) ×4.5
F10	H34412C110	Screw	2	SM9/64 (40) ×4
F11	HH404G8001	Reversing spring	1	
F12	HH407G8001	Spring plate	1	
F13	H4922J8001	Cover (right)	1	
F14	H4914B8001	Screw	4	SM9/64 (40) ×4
F15	H4909J8001	Fixed blade	2	
F16	H4907J8001	Trimming knife holder	2	
F17	H4906J8001	Bolt	2	SM11/64 (40) ×12
F18	H4905J8001	Screw	2	SM9/64 (40) ×7
F19	HH409G8001	Cam	1	
F20	HA710E0692	Screw	2	SM1/4 (40) ×9.5
F21	HA113F0684	Screw	2	SM15/64 (28) ×8.5
F22	H6904J8001	Bushing	1	
F23	H4979K8001	Solenoid complete	1	
F24	H4977K8001	Mounting plate	1	
F25	H003008050	Nut	2	GB/T6172.1 M5
F26	H4951K8001	Nut	1	SM11/64 (40)
F26	H4951K8001	Nut	1	SM11/64 (40)
F27	H4974K8001	Arm	1	
F28	HA111G0683	Screw	1	SM11/64 (40) ×12
F29	H4981K8001	Holder	1	
F30	H4972K8001	Screw	1	SM11/64 (40) ×6.8
F31	H4971K8001	Lever	1	
F32	H4970K8001	Screw	1	SM11/64 (40) ×6
F33	H4967K8001	Screw	3	SM11/64 (40) ×7
F34	H4966K8001	Stopper	1	
F35	H411050160	Screw	2	GB/T819.1 M5×16
F36	H3205G1114	Screw	2	M5×5
F37	H4957K7101	Vibrating crank complete	1	
F38	H4943K8001	Spring	1	
F39	HA100H2080	Pin type	1	
F40	H4965K8001	Set plate	1	
F41	H2012N0652	Screw	1	SM1/4 (24) ×16
F42	H4963K8001	Shaft	1	

## F.KNIFE MECHANISM

Fig. No.	Part No.	Description	Pcs.	Remarks
F43	H4944K8001	Screw	1	SM11/64 (40) ×5.5
F44	H4936K8001	Screw	2	M5(0.5)×8.5
F45	H3405D0663	Ball joint (right)	1	
F46	H003002050	Nut (right)	1	GB/T6170 M5
F47	H4939K8001	Bolt	1	
F48	H4940K8001	Nut (left)	1	M5(left)
F49	H4987K8001	Ball joint (left)	1	
F50	H4912K8001	Arm		
F51	H4913K8001	Bolt	1	SM15/64 (28) ×12.5
F52	H4905K8001	Screw	2	M5(0.5)×7.5
F53	H4980K8001	Holder	2	
F54	HA300B2170	Screw	2	SM11/64 (40) ×8
F55	HH405G8001	Bracket	1	
F56	HA700N0080	Screw	1	SM15/64 (28) ×12
F57	HA100E2150	Screw	1	SM11/64 (40) ×10
F58	HH406G8001	Screw	1	SM11/64 (40)

# G. LOWER SHAFT & OIL LUBRICATION MECHANISM

---

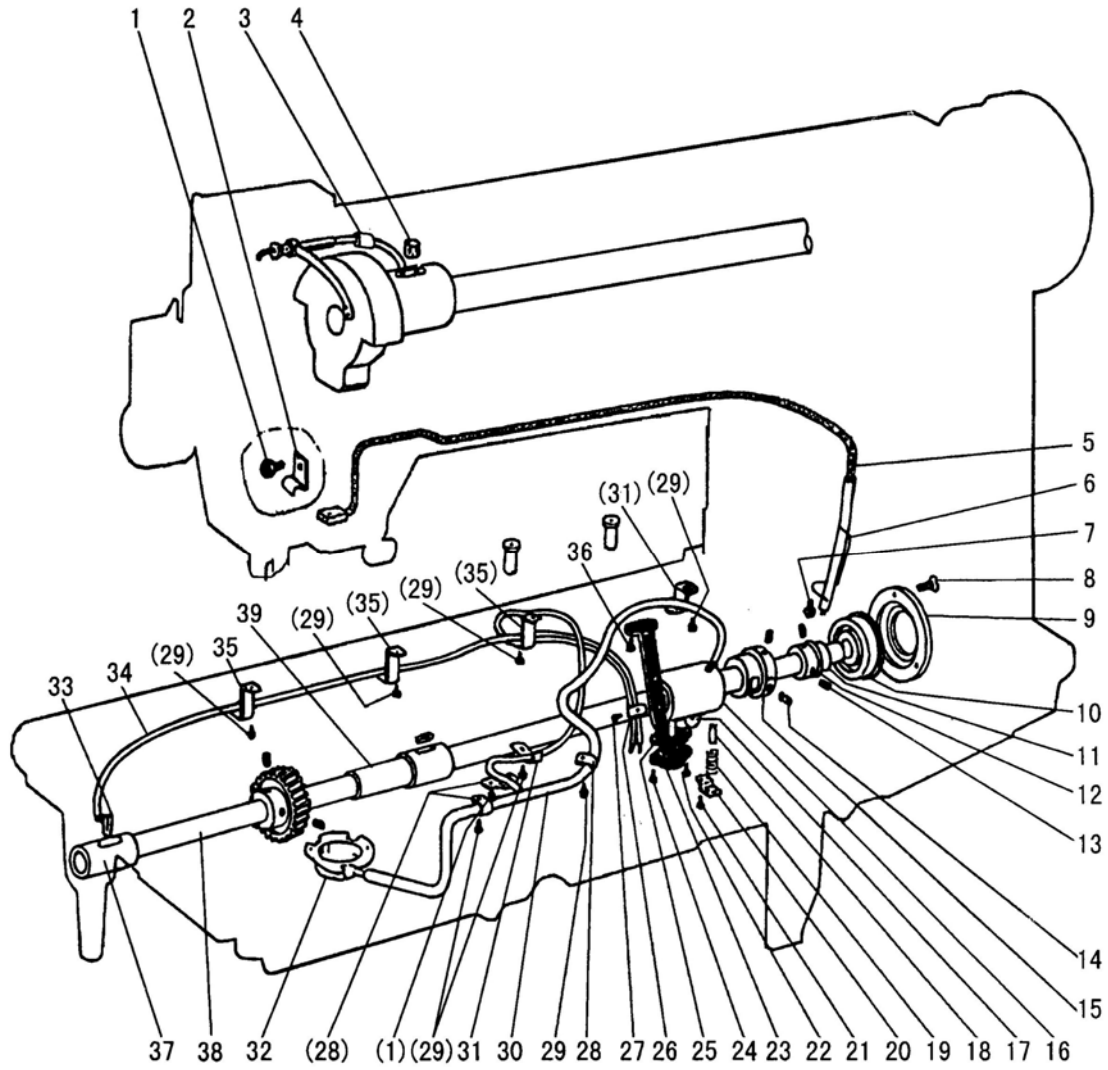

## G.LOWER SHAFT & OIL LUBRICATION MECHANISM

Fig. No.	Part No.	Description	Pcs.	Remarks
G01	HA300C2030	Screw	4	SM11/64(40)×8
G02	H3200K0170	Holder	1	
G03	H32422C208	Pipe	1	
G04	H32175B304	Felt	2	
G05	H3209K0066	pipe & felt complete	1	
G06	H3200K0200	Holder	1	
G07	HA300B2170	Screw	3	SM11/64(40)×9
G08	HA7311C306	Screw	3	SM9/64(40)×7
G09	H3200H2060	Bearing holder	1	
G10	H3208H0661	Ball bearing	1	
G11	H3208H0662	Bushing	1	
G12	HA112D3012	Ring	1	
G13	HA105D0662	Screw	2	SM1/4(40)×4
G14	H3230K0751	Screw	2	SM11/64(40)×10
G15	H3230K0752	Bushing	1	
G16	HH404H7101	Lower shaft bushing middle (complete)	1	
G17	H3215K0696	Pipe	1	
G18	H1100I2070	Pin	1	
G19	H1100I2090	Spring	1	
G20	H1100I2110	Spring holder	1	
G21	H3204D6510	Screw	1	SM1/8(44)×4.8
G22	H3215K0693	Screw	1	SM9/64(40)×5
G23	H3215K0692	Filter	1	
G24	H3215K0694	Screw	1	SM9/64(40)×7
G25	H3215K4011	Base plate complete	1	
G26	H3215K0695	Holder	1	
G27	HA106B0676	Screw	1	SM9/64(40)×6
G28	H32311D606	Holder	3	
G29	HA300B2130	Screw	6	SM11/64(40)×5.5
G30	HG805J8001	Pipe	1	
G31	H3200K0170	Holder	1	
G32	H3211K0068	Oil reservoir complete	1	
G33	H32132B204	Oil wick	2	
G34	H3216K0070	Oil pipe & wick complete	1	
G35	H3200K0160	Holder	3	
G36	HA100E2150	Screw	2	SM11/64(40)×10
G37	H3204B0032	Lower shaft bushing left (complete)	1	
G38	H3200H2010	Lower shaft	1	
G39	H3204B0043	Lower shaft bushing right (complete)	1	



# H. ACCESSORIES

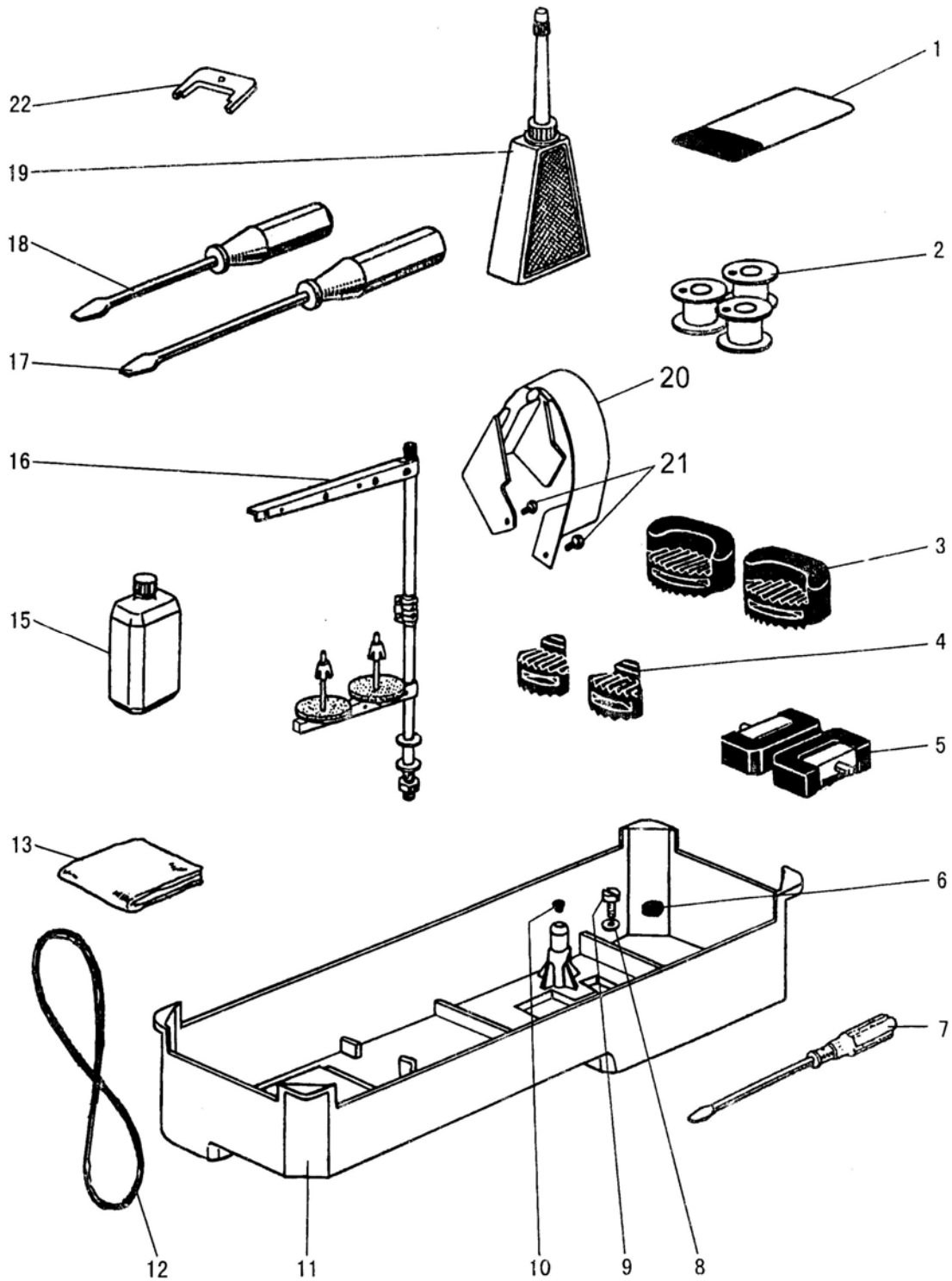

## H.ACCESSORIES

Fig. No.	Part No.	Description	Pcs.	Remarks
H01	HD404D0651	Needle	3	MT×190 16#
H02	H6907H8001	Bobbin	3	
H03	H3200L0020	Vibration preventing rubber	2	
H04	H3200L0030	Vibration preventing rubber	2	
H05	HA307J0067	Hinge complete	2	
H06	HA100J2120	Magnet block for reservoir	1	
H07	HA300J2070	Screw driver(large)	1	
H08	HA104J0653	Washer	1	
H09	HA104J0652	Screw	1	SM5/16(28)×12
H10	HA100B2150	Rubber plug	1	Φ8.8
H11	H3213L0661	Oil reservoir	1	
H12	H4500H2010	V-belt	1	M44
H13	HA100J2180	Vinyl cover	1	
H14	H3218L0681	Felt	1	
H15	H3200L0130	Oil can	1	
H16	HA200J2030	Cotton stand	1	
H17	HA300J2200	Screw driver(middle)	1	
H18	HA300J2210	Screw driver(small)	1	
H19	HA100J2110	Oiler	1	
H20	HH404I7101	Belt cover (complete)	1	
H21	HA300J2280	Screw	2	SM15/64 (28) ×8
H22	HA704S0654	Adjusting plate for speed command disk	1	

**SHANGHAI BIAOZHUN HAILING SEWING MACHINERY CO., LTD.**

**ADD: NO.850 Shulin Road, Songjiang District Shanghai, P.R.China**

**Zip Code: 201612**

**Overseas Business: TEL: 86-21-64853303 FAX: 86-21-64854304**

**E-mail:sales@highlead.com.cn      <http://www.highlead.com.cn>**

The description covered in this manual is subject to change for improvement of the commodity without notice

2018.5. Printed